

SAFETY & RELIEF VALVES

Low Pressure Steam Heating Boiler Safety Valves

12-200 SERIES



Medium capacity safety valves protect ASME Section IV low pressure steam heating boilers. Cast bronze, full nozzle design features PTFE faced elastomer soft seating for dependable operation. Ideal for OEM applications.

ASME Section IV

Sizes 2, 2-1/2" and 3"

Factory set pressures 5-15 psig



HV
Section IV
Heating Boilers

APPLICATIONS:

Medium and large commercial and industrial steam heating and processing boilers.

FEATURES:

- All bronze construction
- PTFE-coated O-ring seat seal
- 3/8" NPT side tapping for drain
- Rust-proofed steel spring
- Top guided, high capacity design
- Registered in all Canadian provinces and territories, CRN #0G8547.5C
- National Board certified at 15 psig

DIMENSIONS AND WEIGHTS

Model Number	Size (in./mm.)		Wt./Ea. (lbs./kg.)	Dimensions (in./mm.)			
	Inlet NPT	Outlet NPT		A	B	C	D
12-205	2M	2F	5.1	6.00	3.75	2.62	4.00
	50	50	2.3	152	95	67	102
12-206	2-1/2M	2-1/2F	8.4	8.50	5.25	3.06	4.00
	65	65	3.8	216	133	78	102
12-208	3M	3F	11.6	9.50	6.00	3.75	4.00
	80	80	5.3	241	152	95	102

NOTE: See Capacities page 15

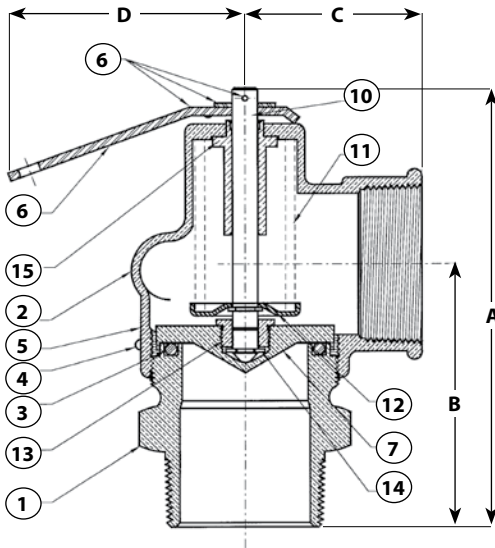

10-512 MATERIALS

Item	Component	Material
1	Nozzle	Bronze ASTM B584
2	Body	Bronze ASTM B584
3	O-ring	Teflon Coated EPDM
4	Drive Screw	AISI 1010 Plated CR Steel
5	Nameplate	Aluminum
6	Handle Assembly	Steel, Plated
7	Disc	Brass ASTM B-16
10	Stem	Brass ASTM B-16
11	Spring	Stainless Steel
12	Spr. Washer	AISI 1010 Plated CR steel
13	Stem Nut	Brass ASTM B-16
14	Retainer Ring	Brass ASTM B-16
15	Guide	Brass ASTM B-16

ORDERING CODE:

Use two-digit suffix number to indicate set pressure and body finish.

P/N SUFFIX KEY

Set Pressure psig	Suffix
5	-03
6	-04
8	-05
10	-06
12	-07
15	-08

EXAMPLE:

12-205-08
2" 12 Series set 15 psig