



ELECTRONIC PRESSURE MEASUREMENT PRODUCTS

Model 575 Series Submersible Level Transmitters

DESCRIPTION

The Model 575 is used in general water/wastewater applications. The transmitter is offered in a standard non-clogging snub nose end, flush diaphragm or protected flush diaphragm with flange base for sewage or sludge type media. The 575 series is CSA approved for intrinsically safe operation when used with an approved safety barrier.

The sensor is designed to provide the convenience of direct submergence in many types of liquids for quick, accurate and reliable measurement. With stainless steel isolation diaphragm (standard) and all 316 stainless steel housing, these solid state instruments provide long lasting service with virtually no maintenance.

The 575 Series transmitters indicate the level of liquid by continuously measuring hydrostatic pressure via its sensing element, an ion implanted silicon semiconductor chip with integral Wheatstone bridge circuit. The pressure measurement is transmitted by a 4-20 mA output signal. This design, with isolation diaphragm for media compatibility, provides for excellent linearity and repeatability, low hysteresis and long term stability with a precision accuracy at $\pm 0.25\%$ FS (BFSL) typical.

The transmitter is easy to install. Simply lower the unit into a tank or vessel. All electronics are mounted in the submersible 316 stainless steel housing and full potting is also provided as an option. A special cable support bracket is also available to provide extra stability when used with longer cable lengths or when used in an agitated liquid. Optional steel support cable is also available for use with the support bracket.

The transmitters are available calibrated for any span needed from 0-6 psi (0-13.8 ft of water, 0-.4 bar, 0-4.2 meters of water) to 300 psi (0-692 ft of water, 0-20 bar, 0-211 meters of water). The transducer is offered as a standard 2 wire, 4-20 mA device.

To complete your liquid measurement and control system, consider the Model DDMC meter/controller or the complete Levelmate III system.

The 575 transducer is manufactured in the United States under ISO 9001:2008 and meets ARRA.

FEATURES

- Low cost measurement solution, easy installation and precision accuracy
- Rugged 316 stainless steel construction and wetted materials resists the corrosive effects of caustic medias with excellent environmental protection, designed for continuous submersion
- 2 wire, 4 to 20 mA output
- Reverse polarity and surge protected with additional lightning and surge protectors as well as EMI protection options
- CSA approved for intrinsically safe operation in hazardous areas in Canada and U.S.
- Full potting option and desiccant available to minimize moisture effects



APPLICATIONS

- Inventory tank measurement
- Ponds, rivers and lakes
- Lift stations and slurries or sludge
- Water/wastewater treatment
- Water wells
- Landfills
- Pump control

Model 575S
standard 1/2 NPT
(with nose cone removed)



Model 575P
protected flush diaphragm



Model 575P

protected flush diaphragm with optional 3/4" plate





ELECTRONIC PRESSURE MEASUREMENT PRODUCTS

Model 575 Series Submersible Level Transmitters

SPECIFICATIONS

Feet of Water: 0/14, 0/35, 0/69, 0/138, 0/230, 0/345, 0/460, 0/690

Meters of Water: 0/4, 0/10, 0/21, 0/42, 0/70, 0/105, 0/140, 0/210

Bar: 0/0.4, 0/1, 0/2, 0/4, 0/7, 0/10, 0/14, 0/20

PSI: 0/6, 0/15, 0/30, 0/60, 0/100, 0/150, 0/200, 0/300

Output: 4 to 20 mA, 2 wire, current limited to 30 mA DC

Power Supply: 12 to 40 VDC with reverse polarity surge protection; limited to 28 VDC for CSA I.S.

Loop Resistance: 1400 ohms maximum at 40 volts

Temperature Range:

General Ambient Operating: -25 to 180°F (-32 to 82°C)**

** CSA intrinsically safe when connected per AMETEK drawing BK750535. Temperature code T3C ambient high temperature limit (T_{amb}) = 104°F (40°C) max.

If submerged in a liquid that has frozen, damage will result

Storage: -40° to 180°F (-40°C to 82°C)

Overrange Effect: $\pm 0.15\%$ full scale at 200% of maximum range

Overrange Limit: 200% of maximum range

Accuracy: $\pm 0.25\%$ full scale, BFSL (including linearity, hysteresis and repeatability); $\pm 0.50\%$ full scale (6 psi range only)

Zero Offset: $\pm 0.50\%$ full scale set at 77°F (25°C)

Span: $\pm 0.50\%$ full scale set at 77°F (25°C)

Temperature Effects: (15 psi and above)

Compensated: 23° to 130°F (-5°C to 55°C); maximum $\pm 1\%$ URL output change for $\pm 25^\circ\text{C}$ temperature change within compensated range when calibrated at 25°C

Consult factory for lower or alternate pressure ranges.

Power Supply Effect: $\pm 0.005\%$ full scale per volt

Construction:

Diaphragm: 316 stainless steel 57 S and M models, HASTELLOY C standard on 575F and 575PB

Housing Type: 316 stainless steel

Nut/Washer Type: 316 stainless steel

Cable Grommet: Viton standard

Housing O Ring: Viton standard

Please contact factory for other cable and grommet materials.

Cable Jacket: Polyurethane (standard)

Media Compatibility: Reference materials of construction

Electrical Connection: Attached 20 gauge polyurethane shielded cable (standard); unspliced lengths available up to 5000 ft. (1662 m)

Consult control drawing or contact the factory for cable length limits for Intrinsically Safe (I.S.) use.

Weight: 1 lb. (454 g) model 575S; 1 lb. 3 oz. (539 g) model 57P with standard base

Approvals: Meets CSA requirements for intrinsically safe operation in hazardous locations as designated by Class I, Div 1, Groups A, B, C & D and Class II, Groups E, F & G. Temperature Code T3C (when used with approved barrier)



Snub Nose: Nylon 6/6 or optional 316 stainless steel; removable to a 1/2" female NPT process connection

Calibration:

NOTE: Units are calibrated 4-20 mA over standard full scale range unless otherwise specified

Examples:

Model 575SB0015NLS will be calibrated as 4 mA = 0 psi, 20 mA = 15 psi or 4-20 mA over 0-34.6 ft. of water

For a special calibration select the appropriate standard pressure range and indicate the special calibration as follows:

Model 575SB0015NLS: Calibrate 0-10 psi or calibrate 0-23 ft. of water

Options and Accessories

- Heavy base for model 57PB, see code "J" under diaphragm material on model code page
- 57PB heavy base field conversion kit
- Allows user to convert standard 57PB to heavy base unit without affecting calibration – order kit part # K680029
- Stainless steel support cable for use with "R" support bracket units. 1/16" diameter cable, order by feet, required part # K515183

See the back page for additional options and accessories.



ELECTRONIC PRESSURE MEASUREMENT PRODUCTS

Model 575 Series Submersible Level Transmitters

575SB or 575MB
Standard 1/2 NPT

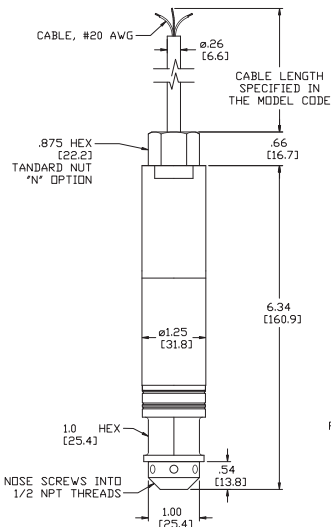

575PB Protected Flush
Diaphragm
1/16" Thick Plate

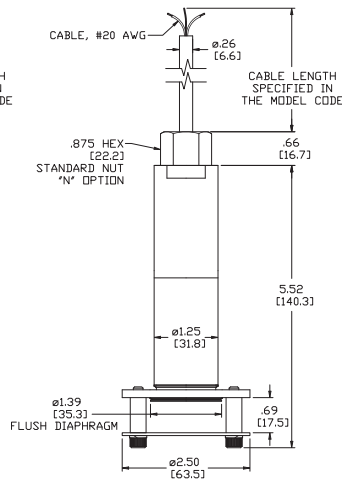

575PB
Flush Diaphragm

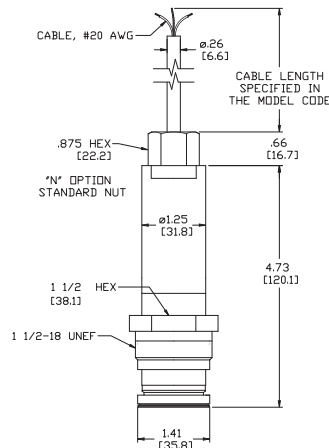

575PB Protected Flush
Diaphragm With 3/4"
Plate (J Option)

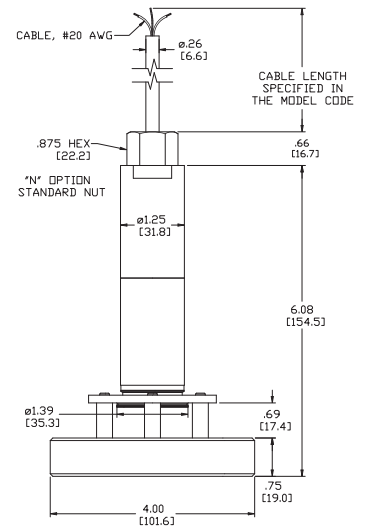

INCHES
(MM)

For Tank, Pipe
or Vessel Mount

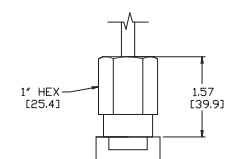
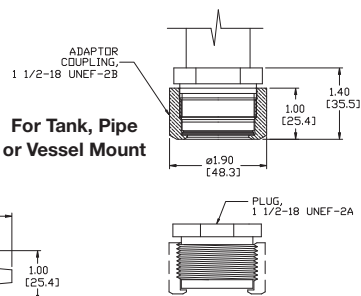

Optional Conduit
Adapter

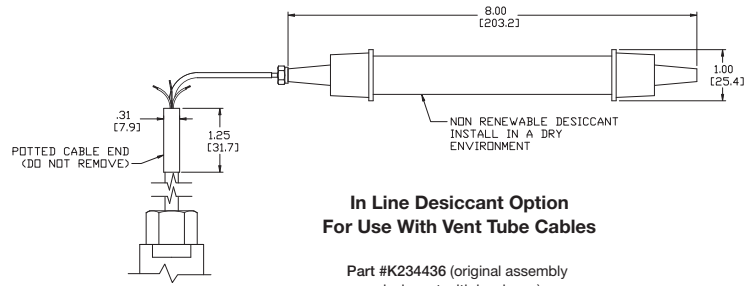

In Line Desiccant Option
For Use With Vent Tube Cables

Part #K234436 (original assembly
desiccant with hardware)

Part #K234446 (replacement cartridge ONLY -
requires some assembly of parts from
original assembly)

Transmitter With
Desiccant

PLUG IS INSTALLED IN COUPLING:
a) WITHOUT A GASKET TO PREVENT DISTORTION
WHILE WELDING COUPLING
b) WITH A GASKET TO SEAL COUPLING

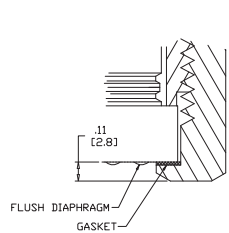

For Tank, Pipe
or Vessel Mount

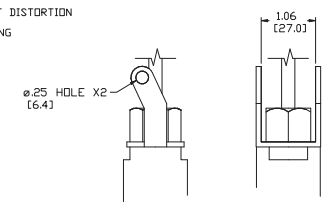

Optional Cable Support
Bracket With Nut and Cable



ELECTRONIC PRESSURE MEASUREMENT PRODUCTS

Model 575 Series Submersible Level Transmitters

Model Numbering:			
575 level transmitter			
575 Series submersible level transmitter			
Sensing port			
S	Nylon snub nose (standard)		
M	Stainless steel snub nose		
F	Flushmount		
P	Protected flush		
Input/Output*			
B	12 to 40 VDC / 4 to 20 mA		
Pressure ranges**		Reference equivalents	
PSI	BAR		
0006	0.4B	0-13.8 ft. water	0-4.2 meters water
0015	001B	0-34.6 ft. water	0-10.5 meters water
0030	002B	0-69.2 ft. water	0-21.1 meters water
0060	004B	0-138 ft. water	0-42.2 meters water
0100	007B	0-230 ft. water	0-70.3 meters water
0150	010B	0-345 ft. water	0-105.4 meters water
0200	014B	0-460 ft. water	0-140.6 meters water
0300	020B	0-690 ft. water	0-211 meters water
Electrical connection			
N	Polyurethane cable w/ nut (standard)		
R	Polyurethane cable w/ nut and cable support bracket		
C	Polyurethane cable w/ conduit adapter		
D	Polyurethane 22AWG cable w/ vent tube (K515072), potted w/ standard nut		
E	Polyurethane cable w/ EMI protection and nut		
F	Polyurethane cable w/ EMI protection, nut and cable support bracket		
G	Polyurethane cable w/ EMI protection, conduit adapter		
J	Polyurethane 22AWG cable w/ vent tube (K515072), potted w/ standard nut and cable support bracket		
S	Teflon cable w/ nut and cable support bracket		
T	Teflon cable w/ nut		
V	Teflon cable w/ conduit adapter		
Diaphragm material			
H	Hastelloy C (standard for 575F and 575PB)		
L	316 stainless steel (standard)		
M	Monel (consult factory)		
Fill fluid			
S	Silicone oil		
M	Mineral oil		
Cable length (specify in feet)*** Enter as separate line item			
	K515076	Polyurethane (standard)	
	K515075	Teflon	
	K515072	Polyurethane w/ vent tube	
575	S	B	0015 N L S (100 feet of cable – K515076)

* Please contact the factory for availability of different input / output options

** Calibrated ranges can be specified after the model code; the specific range should be between the upper and lower ranges in the category selected

*** Note: Unspliced lengths available up to 5000 feet (1662m)

Please contact factory for other options



OPTIONS AND ACCESSORIES

Display Meters, Surge Protectors, Junction Boxes and Desiccants

DISPLAY METERS AND SYSTEMS

Model DDMC Digital Meter/Controller

Dual display meter provides power to the sensor with alarm and 4-20 mA analog output options. Standard panel mount housing or a NEMA 4X weathertight housing for field mounting is available. The weathertight housing also provides internal mounting locations for lightning and surge protectors.



LEVEL MATE™ III Level Measurement System

The complete LEVEL MATE III system includes a level sensor (various models are available), cable and a meter/controller all packaged in a NEMA 4X enclosure. Everything is factory programmed for easy installation and the LEVEL MATE III has an extended 2-year warranty.

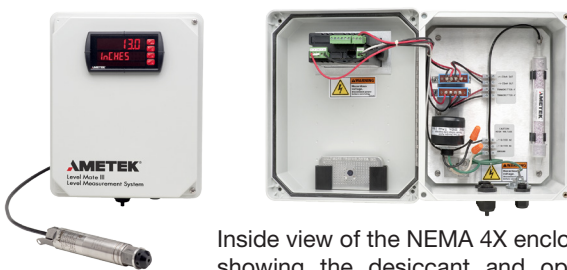

Inside view of the NEMA 4X enclosure showing the desiccant and optional surge protectors. Unit is factory wired so that the user needs to connect power and sensor only.

JUNCTION BOXES

Model SBJ100 with Reusable Desiccant

These boxes are used on long cable runs and provide quicker access to atmospheric reference. SBJ100 provides a clean, dry enclosure with an internal, reusable desiccant canister.

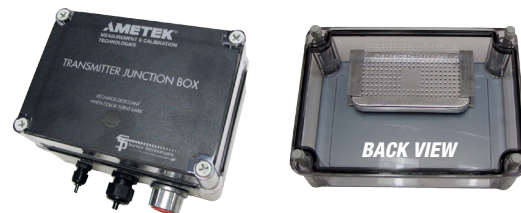

Back view of SBJ100 junction box that shows the reusable desiccant canister.

DESICCANTS

An initial desiccant is supplied with the SBJ100 and the LEVEL MATE III enclosure. The desiccant canister is reusable with visible color change when the time comes to replace the desiccant.

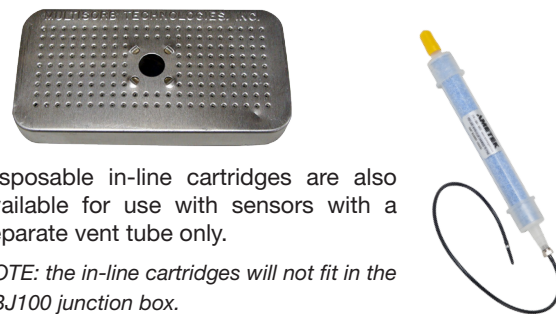

Disposable in-line cartridges are also available for use with sensors with a separate vent tube only.

NOTE: the in-line cartridges will not fit in the SBJ100 junction box.

LIGHTNING AND SECONDARY SURGE PROTECTORS

Lightning protection units are available to help protect systems and components from lightning and secondary surges. These LP units are available in both 30 VDC (LMA912) for 24 VDC supply on excitation/signal lines and analog meter output lines to protect the meter and/or the transmitter as well as 115 VAC (LMA918) and 230 VAC (LMA919) to protect the meter on AC power input lines.

