

BACKFLOW PREVENTION CATALOG

Double Check Valve Backflow Preventers

DCLF 4An SERIES

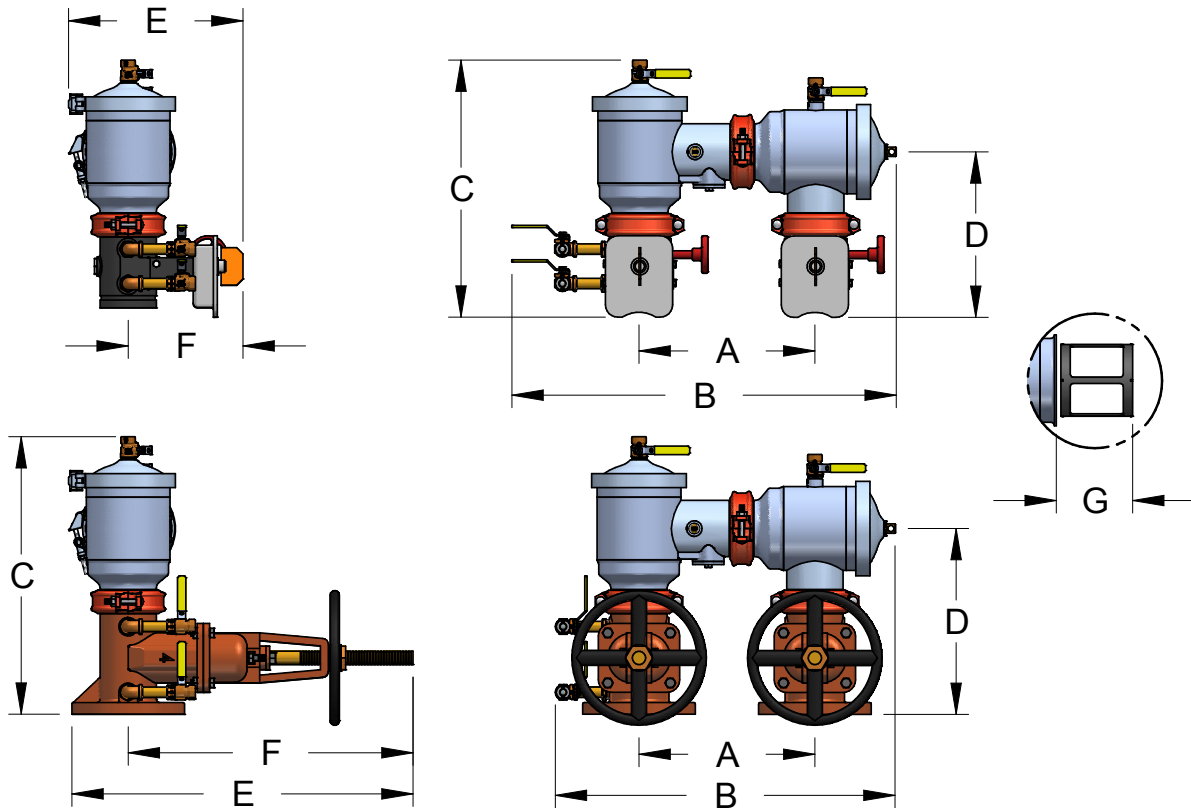

DIMENSIONS

Nominal dimensions are shown. Allowances must be made for manufacturers' tolerances ($\pm 1/8"$ (3 mm) per joint)
See Page 57 For Flow Curves

DIMENSIONS	2-1/2"	60mm	3"	75mm	4"	100mm	6"	150mm	8"	200mm	10"	250mm	12"	300mm
A (Centerline to Centerline)	12-1/2 \pm	318 \pm	12-1/2 \pm	318 \pm	14 \pm	356 \pm	16 \pm	406 \pm	18-1/2 \pm	470 \pm	21 \pm	533 \pm	26-3/4 \pm	679 \pm
B Lay Length Space (Butterfly Valves)	27-1/2 \pm	699 \pm	27-1/2 \pm	699 \pm	30-3/4 \pm	781 \pm	36 \pm	914 \pm	37-3/8 \pm	949 \pm	43 \pm	1092 \pm	N/A	N/A
B Lay Length Space (Gate Valves)	24-1/2 \pm	662 \pm	24-1/2 \pm	662 \pm	27 \pm	686 \pm	32 \pm	813 \pm	40-3/4 \pm	1035 \pm	49 \pm	1245 \pm	55-3/4 \pm	1416 \pm
C (Butterfly Valves)	18-1/4	464	18-1/2	470	20	508	24-3/4	629	28-1/2	724	35	889	N/A	N/A
C (Gate Valves)	19-5/8	498	20	608	22-1/2	572	27-3/4	705	32-1/8	816	40	1016	44	1118
D (Centerline to bottom Butterfly Vlv)	11-1/2	292	11-3/4	298	13-1/4	337	15-3/8	391	17-7/8	453	19-3/4	502	N/A	N/A
D (Centerline to bottom Gate Valve)	13	330	13-1/2	343	14-7/8	378	18	457	21-3/8	543	24-3/4	629	28-3/4	730
E (Butterfly Valves)	11-1/2	292	12-1/8	308	12-7/8	327	15-7/8	403	22-1/4	556	23-1/8	587	N/A	N/A
E (NRS/PI Valves)	14-7/8	378	16-1/8	410	19-1/4	489	24-1/2	622	29-1/4	743	36-3/8	924	40	1016
E (OS&Y Open Valves)	19-7/8	505	24-1/4	616	27-1/4	692	32-3/4	832	44-1/2	1130	54	1372	62-3/4	1594
F (Butterfly Valves)	8	703	8-3/8	213	9	229	10-7/8	276	12-7/8	327	13-1/2	343	N/A	N/A
F (NRS/PI Valves)	11-3/8	289	12-3/8	314	14-3/4	375	19	483	22-1/2	572	26-1/2	673	30	762
F (OS&Y Open Valves)	16-3/8	416	20-1/2	521	22-3/4	578	28	711	37-3/4	959	46	1168	53-1/8	1349
G (Check Removal Clearance)	6	152	6	152	6	152	8	203	8-1/2	216	12	305	12	305
Test Cocks (NPT)	1/2"	13	1/2"	13	1/2"	13	3/4"	20	3/4"	20	3/4"	20	3/4"	20
WEIGHTS	lb.	kg	lb.	kg	lb.	kg	lb.	kg	lb.	kg	lb.	kg	lb.	kg
Net Wt. (Less Shut-offs)	30	14	30	14	39	18	74	34	305	138	785	356	910	413
Net Wt. (w/ Butterfly Valves)	57	26	60	27	84	38	142	64	436	198	963	437	N/A	N/A
Net Wt. (w/NRS Gate Valves)	116	53	141	64	188	85	313	142	768	348	1431	649	2047	929
Net Wt. (w/ OS&Y Gate Valves)	126	57	151	69	194	88	323	147	782	355	1453	659	2101	953

Notes:

1. Internal body connections are grooved on 2-1/2" to 10" sizes.
2. Internal body connections are flanged on 12" size.



For additional information, submittal sheets and manuals, visit www.apollovalves.com

Customer Service (704) 841-6000