

LIQUID DRAINERS

WLD1800/1800R Series

Guided Float Type Liquid Drain Trap

Model	WLD1800, WLD1800R
Sizes	1/2", 3/4"
Connections	NPT
Body Material	Stainless Steel
PMO Max. Operating Pressure	400 PSIG
TMO Max. Operating Temperature	500°F
PMA Max. Allowable Pressure	400 PSIG @ 500°F
TMA Max. Allowable Temperature	500°F @ 400 PSIG



WLD1800
(Non-Repairable)



WLD1800R
(Repairable)

TYPICAL APPLICATIONS

The **WLD1800/1800R Series** are used on industrial air and gas applications for drainage of liquid from systems.

HOW IT WORKS

This liquid drainer has a float-operated valve that gives the trap a modulating flow characteristic. The amount of liquid flowing into the drainer is sensed by the float which positions the main valve to discharge the liquid at the same rate as it is received.

FEATURES

- **Stainless steel body**
- **All stainless steel internals for longer service life**
- **Guided float ensures proper valve seating on every cycle**
- **Repairable unit available (WLD1800R)**

SAMPLE SPECIFICATION

The liquid drain trap shall have a guided-float operation with a tamper proof seal welded stainless steel body and all stainless steel internals. The unit shall be available with an in-line repairable version. All units to be equipped with FNPT threaded end connections.

INSTALLATION

The installation should include isolation valves to facilitate maintenance and an in-line strainer. The trap must be level and upright for the float mechanism to operate. Trap must be sized and properly located in the system.

MAINTENANCE

Close isolation valves prior to any maintenance. The WLD1800 is non-repairable unit. With the WLD1800R all working components can be replaced. Repair kits include float, lever & seat assembly, and gaskets. For full maintenance details see Installation and Maintenance Manual.

MATERIALS

Body	Stainless Steel, AISI 304
Inlet & Outlet Fittings	Stainless Steel, AISI 304
Float Assembly	Stainless Steel, AISI 304
Valve & Lever Assembly	Stainless Steel, AISI 303
Seat	Hardened Stainless Steel
*Gasket (Repairable only)	Grafoil
Washer, Seat	302 Stainless Steel
*Bolt, Hex, HD	Stainless Steel, AISI 316
*Nut, Jam	Stainless Steel, 18-8

* WLD1800R repairable models only.

LIQUID DRAINERS

WLD1800/1800R Series

Guided Float Type Liquid Drain Trap

DIMENSIONS — inches / pounds				
Model	Orifice Size	Size (Inlet x Outlet)	Height A	Weight (lbs)
WLD1811	.078"	3/4" x 1/2"	7.5	4
WLD1811R			7.9	5
WLD1812		3/4" x 3/4"	7.5	4
WLD1812R			7.9	5
WLD1813		1/2" x 1/2"	7.5	4
WLD1813R			7.9	5
WLD1821	.101"	3/4" x 1/2"	7.5	4
WLD1821R			7.9	5
WLD1822		3/4" x 3/4"	7.5	4
WLD1822R			7.9	5
WLD1823		1/2" x 1/2"	7.5	4
WLD1823R			7.9	5
WLD1831	.125"	3/4" x 1/2"	7.5	4
WLD1831R			7.9	5
WLD1832		3/4" x 3/4"	7.5	4
WLD1832R			7.9	5
WLD1833		1/2" x 1/2"	7.5	4
WLD1833R			7.9	5

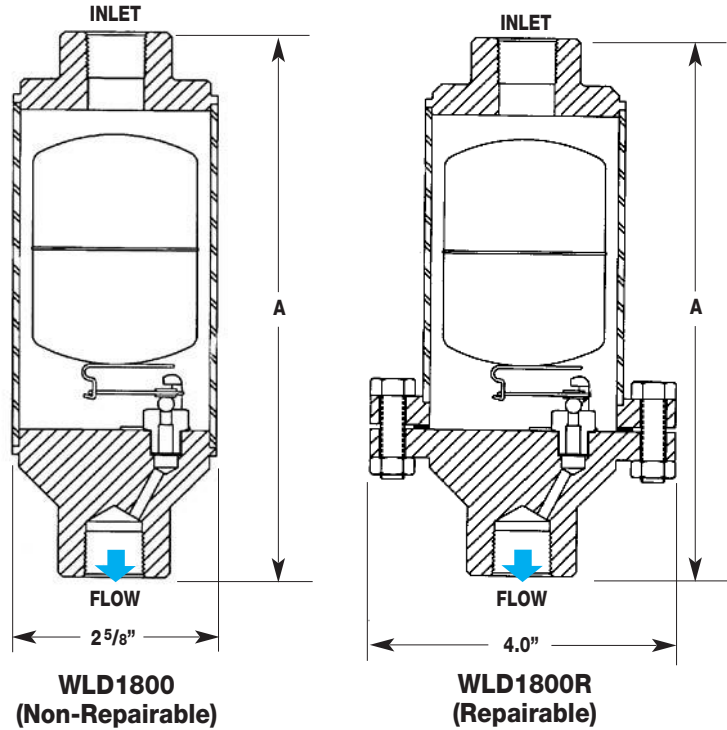

LIQUID DRAINERS

CAPACITIES — Cold Water (lbs/hr)																			
Series	PMO* (PSIG)	Orifice Size	Differential Pressure (PSI)																
			1	2	5	10	15	20	30	50	100	150	175	200	250	275	300	350	400
WLD1810	400	.078"	60	80	120	130	180	260	315	400	570	700	750	800	900	940	1050	1050	1120
WLD1820	255	.101"	90	120	175	195	275	385	470	610	860	1050	1125	1200	1350	1425			
WLD1830	175	.125"	160	230	325	365	510	730	790	1150	1630	2000	2150						

* PMO based on a liquid with a specific gravity of 1.0. Consult factory for the PMO of a liquid with specific gravity less than 1.0.

CAPACITY CORRECTION FACTORS																		
Specific Gravity	1	.98	.96	.94	.92	.90	.88	.86	.84	.82	.80	.75	.70	.65	.60	.55	.50	
Correction Factor	1	.99	.98	.97	.959	.949	.938	.927	.917	.906	.894	.886	.873	.860	.847	.834	.821	.807

Note: To obtain capacity with a liquid other than water, multiply water capacity by correction factor.

HOW TO SIZE/ORDER

Determine differential pressure and capacity (lbs/hr) required. Locate differential pressure on capacity chart; move down column to capacity required. Make sure to select the correct model based on the required inlet pressure. Example:

Application: 1,000 lbs/hr at 250 PSIG working pressure and 200 PSI differential pressure
 Size/Model: 3/4" x 3/4" **WLD1822** @ 1,200 lbs/hr (non-repairable) or 3/4" x 3/4" **WLD1822R** @ 1,200 lbs/hr (repairable)