



PNEUMATIC CONTROLLERS AND TRANSMITTERS

Model 40 Pneumatic Indicating Controllers

DESCRIPTION

Model 40 Pneumatic Controllers automatically position a valve or other final control element to maintain process pressure at the desired set point. As receiving controllers, they can control any process variable transmitted as a pneumatic signal.

Standard models have proportional band adjustments for controlling processes where load changes are infrequent and can be corrected by the manual reset feature, standard in every controller. By a simple screwdriver adjustment, the standard proportional controller can be changed to two-position control action with adjustable differential gap.

Model 40 controllers are available with control modes of 100% proportional, 200% proportional plus reset and 300% proportional plus reset plus rate (PID) for processes with frequent load changes. They not only satisfy ordinary control requirements, but are equally proficient in controlling processes with unfavorable characteristics.

The basic instrument is also available as an indicating pneumatic transmitter. Mounted close to the point of measurement, it transmits an air pressure signal proportional to the measured variable to another indicator, recorder or controller.

FEATURES

- Quality, flexibility, accuracy and dependability
- Indication of measured variable
- A non-bleed, high-capacity relay with excellent stability and fast response
- Easy field calibration
- Broad selection of control modes; proportional plus reset, proportional plus reset plus rate, differential gap and two position bypass
- Wide selection of process measuring elements for pressure, differential pressure, flow and level
- Large, easy-to-read black on white dial for maximum resolution
- Case and door with epoxy powdered finish for environmental protection

SPECIFICATIONS

INDICATION ACCURACY: 1% middle half of scale, 1-1/2% remainder; most ranges may be calibrated to 1/2% accuracy at nominal extra charge

SENSITIVITY: Less than 0.1% of full scale at 100% proportional band

FREQUENCY RESPONSE: Flat to 400 CPM with 200 feet of 1/4" tubing and 1.2 cubic inch capacity. Flat to 120 CPM with 18' 3/8" tubing and 200 cubic inch capacity

CONSTRUCTION: Moving parts are designed as light as possible to keep friction and inertia forces low, also resulting in higher resistance to vibration and shock

MOUNTING: Surface, flush panel, pipe-supported or valve-mounted; dimensions on page 8

AIR SUPPLY: 20 psi for 3-15 psi range; 35 psi for 3-27 and 6-30 psi range; 65 psi for 12-60 psi range.

A filter and dripwell are recommended ahead of each controller to ensure clean, dry air supply; may be operated on natural gas or bottled CO₂

CONNECTIONS: Standard back connections are 1/4" female NPT

MEASURING ELEMENTS: A wide range of precalibration measuring elements for pressure available – consult factory

MODULAR CONSTRUCTION: Each of the following components may be removed without disturbing the other components: control chassis complete, precalibrated elements, feedback assemblies, complete relay units, or supply gauge only, nozzle feed orifice and cleaner assembly only, relay diaphragm housing and valve stem only, output gauge and tubing only



Model 40
Pneumatic Controllers



PNEUMATIC CONTROLLERS AND TRANSMITTERS

Model 40 Pneumatic Indicating Controllers

Guide to Controller Selection			
Type Of Process Dynamics	Description	Examples	Control Required
Capacity Lag Large Tank	Found when there is an appreciable inventory or storage of the controlled medium	Level control in process retention tanks; batch heating	On-Off differential gap
Transfer Lag	Found when it is necessary to force corrective action through a resistive element before it affects the process	—	Proportional plus rate plus reset
Instantaneous Response	Found when the manipulated variable is the same as the controlled variable or if they are dynamically equal	Flow control, pressure control or liquids in pipelines or other vessels completely filled with the liquid	Proportional plus reset
Velocity/Distance Lag	Found when the measuring device is downstream of the point of corrective action; equals the separating distance ÷ the stream velocity	Any process control requiring reaction time before measurement or any analytical variable control loop where the sampling system produces dead time	Proportional plus slow reset (do not use rate); eliminate dead time if possible

CONTROL ACTIONS

Proportional Control: This action provides an output signal proportional to the measured variable. Standard output pressure for controllers is 3-15 psi with proportional band adjustment of 1 to 100%. Band widths to 200% are also available. Outputs of 6-30 psi and 3-27 psi are optional. An index on the chassis plate of the controller permits precise setting of band widths. Proportional control alone is ideal for process pressure regulation service (upstream) or relief service (downstream). Standard proportional controllers are recommended for most batch processes and a great many continuous processes where load changes are small or infrequent.

Proportional Plus Reset Action: When load changes are large or frequent and the process will not tolerate quick or drastic changes in control action, automatic reset is desirable to avoid excessive offset from the desired value under wideband proportional control. The feedback diaphragm on the standard proportional controllers is replaced with a reset assembly. A standard reset needle valve offers a wide range of settings from 0.03 to 5.0 minutes per repeat (optional 0.03 to 0.5 minutes repeat available).

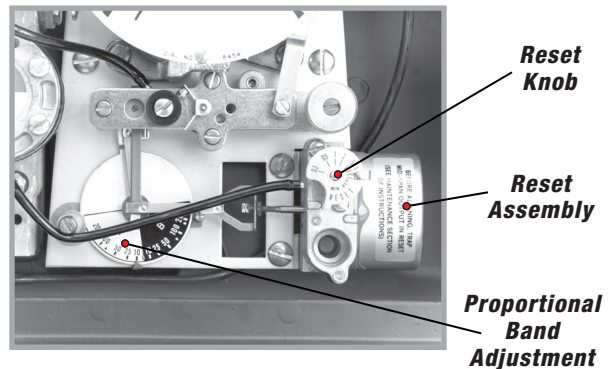
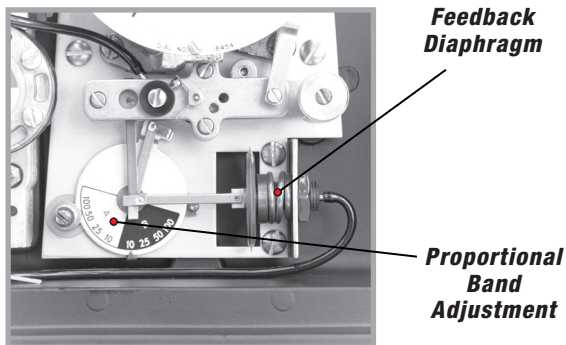

Differential Gap Action: This is a two-position control mode standard in all Model 40 Proportional Controllers. The output pressure of the controller remains at maximum (20 psi standard) or minimum (0 psi) until the controlled measurement crosses a band or gap, causing the output pressure to reverse. The measured variable must then span the gap in the opposite direction before the output signal is restored to the original condition. Differential gap action is useful in controlling pumps and compressors to prevent excessive on-off cycling. Several controllers set in sequence with overlapping bands may be used for cutting in several stages of a process successively and cutting them out in reverse order. Gap may be adjusted over the full range of the proportional band.



PNEUMATIC CONTROLLERS AND TRANSMITTERS

Model 40 Pneumatic Indicating Controllers

FEATURES

- 1 ADJUSTING WRENCH** – 1/4" x 1/8" stored on door can be used for all necessary adjustments on movement, pointers and nozzle.
- 2 SHROUD** – Anodized aluminum shroud brightens dial area for greater visibility under adverse lighting conditions.
- 3 FINISH** – Die-cast aluminum with semi-flat black powdered epoxy finish.
- 4 ORIFICE** – Sapphire 0.008" bore with integral push-button cleaner.
- 5 RELAYS** – Non-bleed, high capacity relay is standard on all controllers. Bleed rate of less than 0.1 SCFM at 9 psi output and the capacity to deliver over 3.0 SCFM result in an exceptionally stable, fast responding controller. May be easily dismantled for cleaning without disturbing factory-set adjustments. Anodizing is available for maximizing corrosion resistance.
- 6 PROPORTIONAL BAND ADJUSTMENT** – Adjustable by screwdriver within 90 degree quadrant indicated on dial. For available band widths and control options, consult factory.
- 7 NOZZLE** – Specifically designed for increased stability of pneumatic circuit; nickel silver nozzle can be turned on turret to reverse control action; 0.018" bore.
- 8 DIAL** – Large, easy-to-read black on white dial face with full 7" scale for maximum resolution.
- 9 PROCESS INDICATIONS** – Black adjustable pointer on 3-1/2" precision gauge dial (7" scale length). Readily adjusted to compensate for hydrostatic heads in piping.
- 10 CASE** – Cast aluminum with dust ledge and deep weatherproof gaskets, captive stainless hinge pins and latch shaft, and rectangular glass. Optional gas-tight construction with case tapped for 1/2" pipe vent. For high-pressure applications, shatter-proof glass and blowout grommets are available. Anodizing is available for maximizing corrosion resistance.
- 11 MOVEMENT** – Micrometer range adjustment plus adjustable sector and link for scale-shape calibration of both indicating and set point mechanisms provides easy field calibration.
- 12 SET-POINT ADJUST** – Internal or external available.

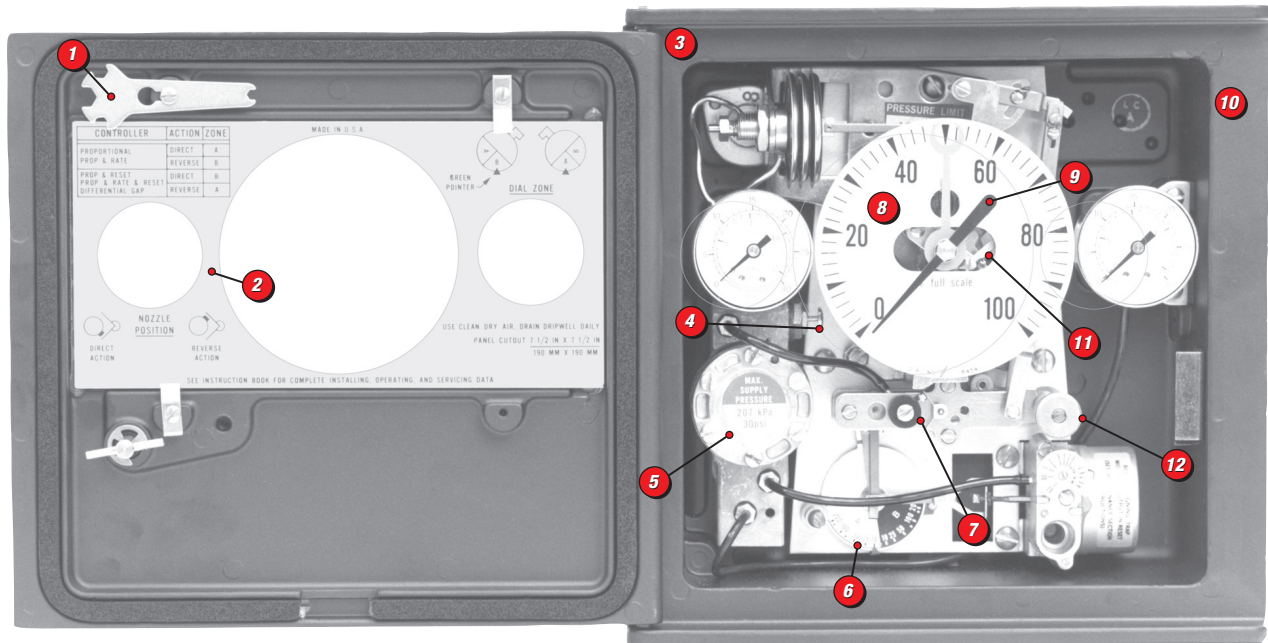



PNEUMATIC CONTROLLERS AND TRANSMITTERS

Model 40 Pneumatic Transmitters

DESCRIPTION

The Model 40 Pneumatic Transmitter is designed to sense pressure and transmit an air signal which is precisely proportional to the measured variable. This output signal from the transmitter may be fed to any remotely located monitoring, recording or control instrument.

Model 40 pneumatic transmitters insure increased safety by eliminating the need for piping high-pressure, toxic, corrosive, inflammable or other dangerous fluids or gases through the plant.

Model 40 transmitters provide an added convenience, in that operation of a single transmitter with its high capacity relay can be used to actuate a number of receivers for indication, recording or control at a number of points throughout a plant. Also, transmitters measuring many different variables provide standard 3-15 psi output signals, thereby reducing all variables to common readout devices and simplifying centralized panelboards and control stations.

Model 40 transmitters are designed, in physical appearance, to match the Indicating Pneumatic Controllers.

FEATURES

- Reliability – highly essential, since a transmitter must operate for extended periods in inaccessible places without attention
- Sensitivity and freedom from deadband – an absolute requirement, since the transmitter constitutes the first instrument in the control loop
- High accuracy and repeatability – mandatory for consistency and control stability
- Measuring elements – ranges and materials are same as those for indicating controllers, however, the element assemblies are not interchangeable between controllers and transmitters
- Stabilized pneumatic circuit – output signal is stabilized with all combinations of output capacity or load and transmission line resistance. Changes in air supply pressure to the transmitter have a negligible effect on the output
- Accuracy – measurement to output, within 1% of full scale on indicating transmitters; 0.5% on most ranges of indicating transmitters available at extra charge
- Feedback assembly – a diaphragm capsule of Ni-Span C provides precise follow-up to maintain exact transmitter calibration
- Air supply and output pressure – 20 psi supply pressure and an output pressure range of 3-15 psi are standard. A filter and drip-well are recommended ahead of each transmitter, to ensure a clean, dry air supply

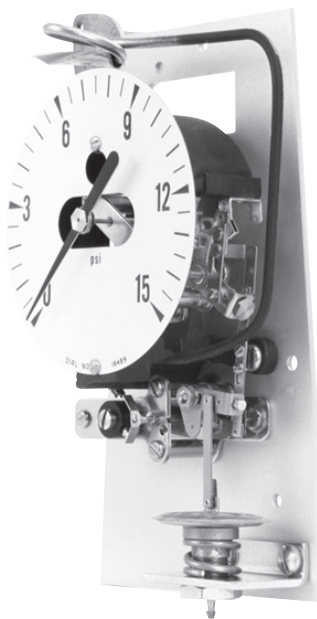

**Model 40
Pneumatic
Transmitter**

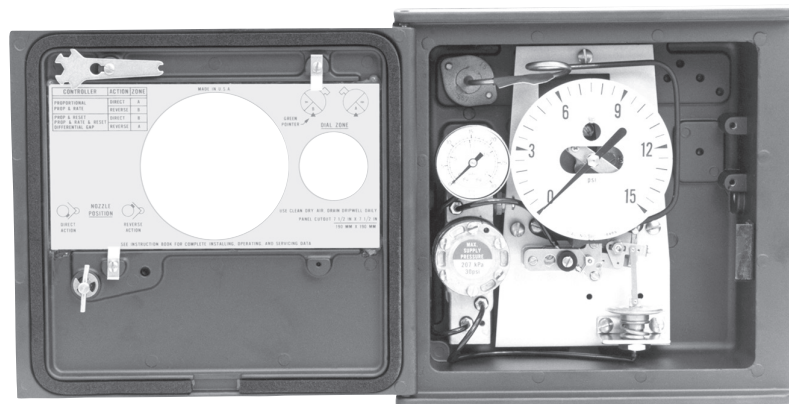



PNEUMATIC CONTROLLERS AND TRANSMITTERS

Precalibrated Measuring Elements

PRESSURE

“C” Type Bourdon Tubes: Model 40 Pneumatic Controllers and Transmitters are furnished with precalibrated “C” type Bourdon tube measuring elements. The wide, powerful Bourdon tube is carefully drawn, coiled and heat-treated to ensure a precise measuring element, permanent in calibration, and having exceptional overrange capacity. Phosphor bronze tubes are soft-soldered into cast brass sockets. Stainless steel elements are inert gas welded to provide maximum corrosion resistance. Standard ranges are listed in Table 1.



**Model 40
Pneumatic
Controller**

Table 1. Bourdon Tube Ranges/Materials

Element Range	Phosphor Bronze	316 SS
0-30" Hg VAC	✓	✓
0-13 to 0-17 psi	✓	✓
0-25 to 0-35	✓	✓
0-50 to 0-70	✓	✓
0-85 to 0-110	✓	✓
0-150 to 0-180	—	✓
0-190 to 0-230	✓	✓
0-250 to 0-350	✓	✓
0-350 to 0-450	—	✓
0-450 to 0-550	—	✓
0-550 to 0-700	—	✓
0-700 to 0-900	—	✓
0-900 to 0-1200	—	✓
0-1200 to 0-1700	—	✓
0-1700 to 0-2300	—	✓
0-2300 to 0-3000	—	✓

✓ = Available elements
Compound ranges available. Consult your representative.

Differential Pressure Cell: The differential pressure element used in the Model 40 controller is available in ranges from 10" W.C. to 400 psid with static working pressure to 3000 psi. The basic unit incorporates a high and low pressure bellows connected to a center plate. When two different pressures are applied to the high and low side, the high pressure bellows contract, forcing the fill fluid through the center plate into the low pressure bellows which expand. The motion of the low pressure bellows is transmitted via a temperature compensated linkage to the instrument output shaft.

Consult factory for available ranges, bellows, housing materials, and static working pressure.



PNEUMATIC CONTROLLERS AND TRANSMITTERS

Precalibrated Measuring Elements

PRESSURE

Diaphragm: Low pressure controllers and transmitters are offered with a standard diaphragm measuring element comprised of stacked capsules of Ni-Span C or stainless steel. Diaphragm capsules are made of contoured plates with nested corrugations and silver-brazed, or welded edges. They have a long working stroke, yet occupy minimum space. A sturdy element with large effective area, this design provides friction-free operation and precise indication. The constant thermal elastic characteristic of Ni-Span C practically eliminates thermal shift with wide variation in ambient temperatures. Welded type 316 stainless steel diaphragms are also offered for the ranges indicated in Table 3. Diaphragm elements are interchangeable with bourdon elements.

Table 3. Diaphragm Ranges/Materials

Element Range	Ni-Span C	316 SS
0-50 to 0-60"	—	✓
0-65 to 0-85"	—	✓
0-120 to 0-160"	—	✓
0-6 to 0-8 psi	—	✓
0-8 to 0-11 psi	—	✓
0-9 to 0-12 psi	✓	—
3-15 psi	✓	✓

✓ = Available elements

Low Pressure Controller

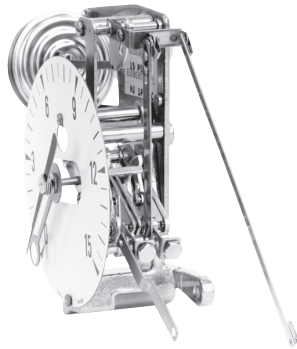

Slack Diaphragms: Extremely low gauge pressures are measured and controlled by molded BUNA-N slack diaphragm elements (Table 4) for measuring clean, dry air only.

Table 4. Low Pressure Diaphragm Ranges

Range Inches H ₂ O	Pressure	Pressure Differential
0-4.5 to 0-8.4	✓	✓
0-8.5 to 14.5	✓	✓
0-14.6 to 0-24.9	✓	✓
0-25 to 0-43.9	✓	✓
0-44 to 0-80	✓	✓

✓ = Available elements
Center zero DP ranges are also available from 4.5/0/4.5 W.C. through 44/0/44 W.C.

Low differential pressures such as encountered in air flow and draft applications are measured by molded BUNA-N slack diaphragm elements. Elements are also used in extremely low compound pressure ranges and vacuum range transmitters and controllers. Differential measurements at static pressures as high as 15 psi can be made.

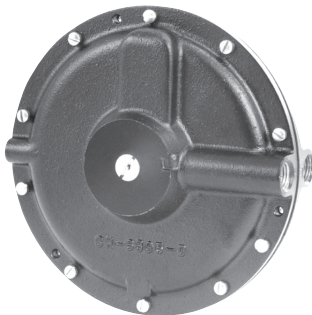

Slack Diaphragm

for measuring clean, dry air only – for other media, see DP cell options



PNEUMATIC CONTROLLERS AND TRANSMITTERS

Model 40 Controller-Pilot Positioner

DESCRIPTION

The Model 40 Controller-Pilot Positioner combines in one compact unit the functions of (a) – an indicating pneumatic controller for pressure, temperature or any pneumatically transmitted variable, and (b) – a valve positioner which amplifies air power to position a pneumatically operated control valve accurately and rapidly.

This instrument accurately positions the valve in response to changes in measured variables as small as 0.1% full scale. It ensures rapid valve response even through full travel and results in economies through use of smaller topworks. Instead of pneumatic feedback from valve stem position, the instrument employs mechanical feedback to the controller through a lever system. Thus the valve is forced to assume a precise position proportional to the controlled variable.

The unit includes a high-capacity, non-bleed relay providing more rapid and accurate positioning. By means of a unique valve stem take-off, the Controller-Pilot Positioner will actuate any diaphragm motor valve with stem travels from 3/8" to 4" in any combination of stem direction and air-to-open or air-to-close topworks. A rear mounting pad provides for the vertical location of the instrument on virtually all makes and sizes of diaphragm motor operators.

The standard Controller-Pilot Positioner operates on any air supply pressure from 20 psi to as high as 65 psi and is available with 1-75% proportional control or 1-75% differential gap action – with easy field reversibility.

It may be actuated by any of the measuring elements described on pages 5 and 6 (except slack diaphragms or DP cells), or it may be used as a pneumatic received in conjunction with a distantly located Indicating Pneumatic Transmitter.

FEATURES

There are several advantages to the Controller-Pilot Positioner over two separate units:

- It is located close to the process and directly on the valve for fast, accurate response
- It needs only one air supply and thus reduces installation and maintenance costs
- It mounts readily on all standard diaphragm valves and other pneumatic actuators
- It saves space required for a second instrument
- It is low in initial cost as well as maintenance and operating costs

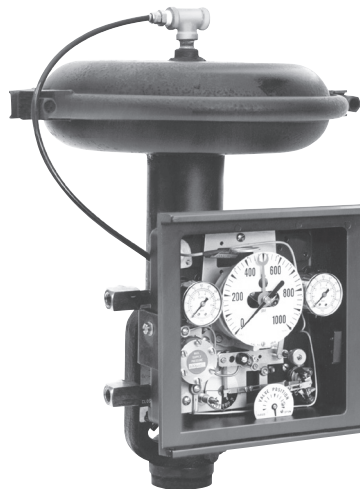

**Model 40
Controller-
Pilot Positioner**



PNEUMATIC CONTROLLERS AND TRANSMITTERS

Model 40 Standard Dimensions

INDICATING CONTROLLER

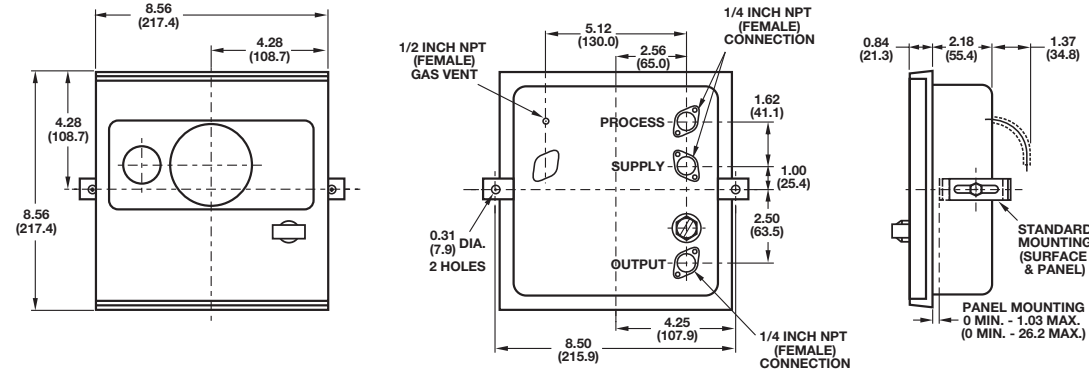

SLACK DIAPHRAGM CONTROLLER

(Not available valve mounted)

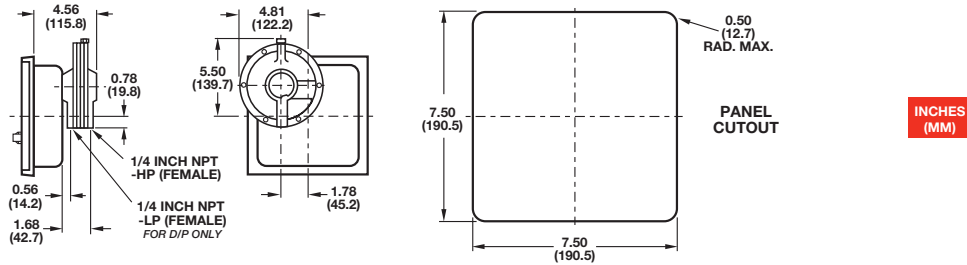

VALVE MOUNTING

(Optional)

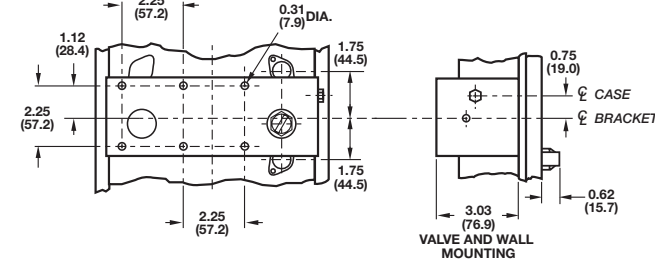

PIPE MOUNTING

(Optional)

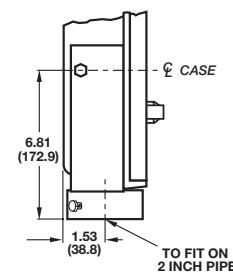

DIFFERENTIAL PRESSURE CONTROLLER

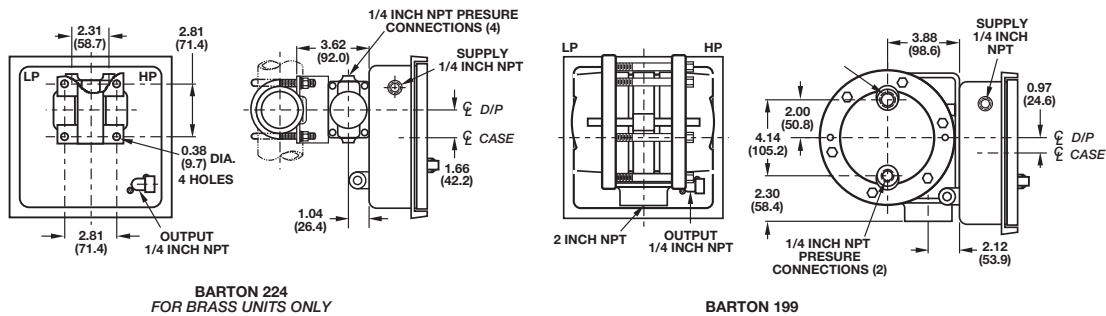



PNEUMATIC CONTROLLERS AND TRANSMITTERS

Pneumatic Indicating Controllers

Model Numbering:										
● Model 40 Pressure Instruments										
Model 40										
● Control Mode										
	1	200% Prop. & Reset	5	75% Prop. (Positioner only)						
	2	100% Prop.	7	300% PID (3/15 psi only)						
	3	200% Prop.								
● Output										
	1	3/15 psi	3	6/30 psi						
	2	3/27 psi	5	12/60 psi (Prop. only)						
● Instrument Type										
	B	Controller w/2 Pos. By-pass (not with PID)								
	K	Controller								
	P	Pilot Positioner (75% Prop. 12/60 out only)								
	T	Transmitter (100% Prop. Only) 3/15 psi only								
● Element Type										
	B	Bourdon Tube			F	Slack Diaphragm (D/P or Center 0)				
	C	Barton #199 (Consult Factory)			I	Barton #224 (Consult Factory)				
	D	Metal Diaphragm (Pressure)			J	Metal Diaphragm (Suppressed Zero)				
				R	Indicating Level					
				S	Slack Diaphragm (Pressure)					
● Element Material										
	0	No Element			7	BUNA				
	1	Bronze			S	Special				
	3	Stainless Steel (316)			8	BUNA-N (Center 0)				
	5	Ni Span C								
● Element Range										
Enter first 2 digits of desired span so that it gives the desired span when multiplied by the multiplier and the unit of measure below Examples: 0 to 100 psi span is 101 (10 x 10 psi); 3 to 15 psi span is 120 (12 x 1 psi)										
● Multiplier and Units										
	0	x 1 psi		3	x 1000 psi					
	1	x 10 psi		5	x 1 in. Water					
	2	x 100 psi		6	x 10 in. Water					
● Engineering Units or Dial Number										
● Options										
	AB	External Set Point Knob								
	AC	Overrange Stop (Element Type B, D, J only)								
	AD	Air Filter, Regulator and Drip Well								
	AG	Shatterproof Glass								
	AH	Blowout Grommet								
	AI	External Reset Connection								
	AM	Metal Tags								
	AP	Vented Case (1/2" NPT)								
	AR	Special Calibration								
	AW	Fast Reset Valve								
	BH	Pipe Mounting Bracket								
	BI	Valve and Wall Mounting Bracket								
	BK	Wall Mounting Bracket								
	BL	Supply Gauge								
	BR	Blank Shroud								
	OX	Cleaned for Oxygen Service								
	-	Custom Scale								
	DQ	Anodized Case, Door, Relay								
Model	40	1	1	B	B	3	30	1	?	BL