

ACTUATORS AND CONTROLS

LB Series Actuator Dimensions

TYPE AT100

Standard specification: Weatherproof to NEMA 4, fitted with two adjustable SPDT travel limit switches (one for each extreme position); two SPDT torque limit switches (one for each direction of rotation) and with handwheel for manual operation. Duty rating 30%.

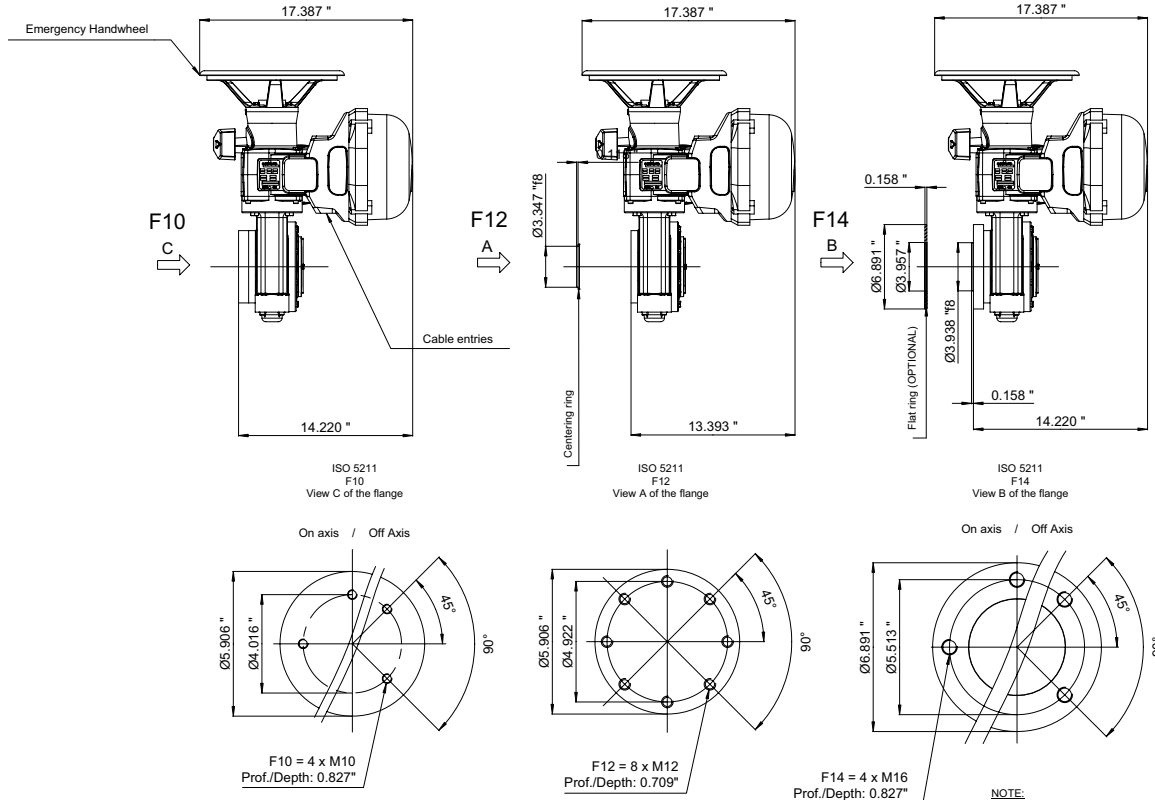
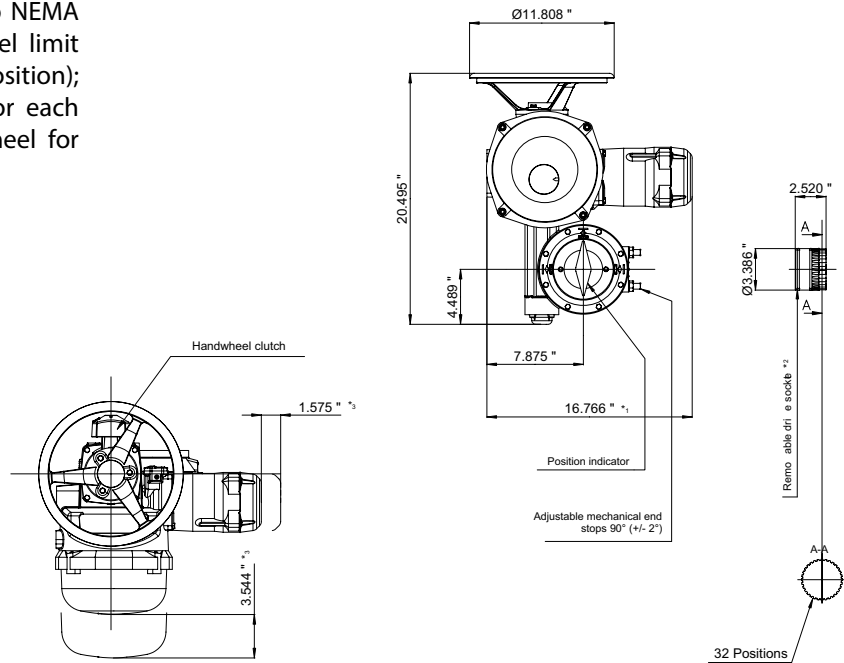

- NOTE:**
- ¹ The actuator is represented in its maximum size.
 - ² Representation of the socket in closed position.
 - ³ Dimension to allow for disassembly