



TEMPERATURE PRODUCTS

Model BAC 3" and 5" Back Connected Industrial Bimetallic Thermometers

DESCRIPTION

U.S. Gauge offers 3" and 5" heavy duty, industrial bimetallic thermometers with a 90° back angle, rear threaded union connection design. These thermometers, with 300-Series stainless steel wetted parts, are rugged and commonly used in industrial, pulp and paper, food and beverage processing, HVAC, and OEM applications.

The standard connection is 1/2-14 NPT, but others are available. The standard lens material is glass. Standard stem diameter, up to 12" long, is .25". Other available stem sizes are .24" (6mm), .32" (8mm), and .375" (9.52mm). Some temperature ranges are NSF certified.



**Model
BAC**

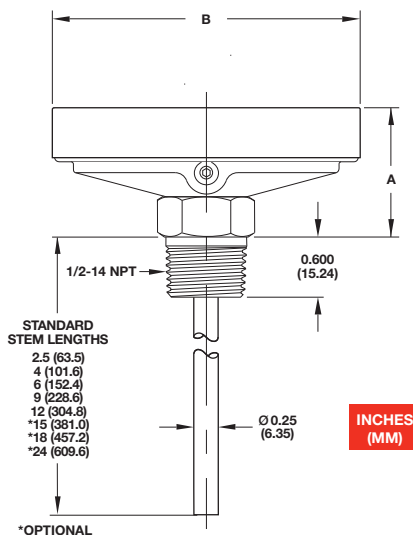

SPECIFICATIONS

STEM DIAMETER: .25" standard up to 12" stem

CONNECTION: 1/2-14 NPT

EXTERNAL RESET: Standard (see photo below)



CONSTRUCTION: 304 stainless steel external parts, welded construction, corrosion resistant to most chemicals

HERMETIC SEAL: Per ASME B40.3, dustproof and leakproof

DIAL: Cupped anti-parallax dial, easy to read from any angle, minimizes reading errors; anodized aluminum with large black numbers and graduations. Outer scale in Fahrenheit; inner scale Celsius.

LENS: Glass

BIMETALLIC COIL: Helix coil is silicone coated on ranges below 500°F for vibration dampening and to maximize heat transfer and response time

ACCURACY: ±1% full span per ASME B40.3 Grade A, when using maximum or minimum temperature indicator, accurate to within 1-1/2% full span

OVER TEMPERATURE LIMITS: Up to 250°F, 100%; 250° to 550°F, 50%; 550° to 1000°F, continuous use up to 800°F, intermittent use over 800°F

Dimensions

Model	Unit	A	B
BAC-3	inches	1.113	3.132
	mm	28.27	79.55
BAC-5	inches	1.113	5.006
	mm	28.27	127.15



TEMPERATURE PRODUCTS

Model BAC 3" and 5" Back Connected Industrial Bimetallic Thermometers

Spec Number Selection Chart

Model BAC-3		3" Dial Size				
Connection	Temperature Range*	2-1/2" Stem Length	4" Stem Length	6" Stem Length	9" Stem Length	12" Stem Length
		Spec No.	Spec No.	Spec No.	Spec No.	Spec No.
1/2-14 NPT	25° to 125° FC	415086	415093	415100	415107	415114
	0° to 200° FC	415087	415094	415101	415108	415115
	0° to 250° FC	415088	415095	415102	415109	415116
	50° to 300° FC	415089	415096	415103	415110	415117
	50° to 400° FC	415090	415097	415104	415111	415118
	50° to 550° FC	415091	415098	415105	415112	415119
	200° to 1000° FC	415092	415099	415106	415113	415120
Model BAC-5		5" Dial Size				
Connection	Temperature Range*	2-1/2" Stem Length	4" Stem Length	6" Stem Length	9" Stem Length	12" Stem Length
		Spec No.	Spec No.	Spec No.	Spec No.	Spec No.
1/2-14 NPT	0° to 200° FC	415121	415127	415133	415139	415145
	0° to 250° FC	415122	415128	415134	415140	415146
	50° to 300° FC	415123	415129	415135	415141	415147
	50° to 400° FC	415124	415130	415136	415142	415148
	50° to 550° FC	415125	415131	415137	415143	415149
	200° to 1000° FC	415126	415132	415138	415144	415150

* All dials are dual scale, Fahrenheit outer scale, Celsius inner scale