

# SAFETY & RELIEF VALVES

## Bronze Safety Valves

### 19 SERIES

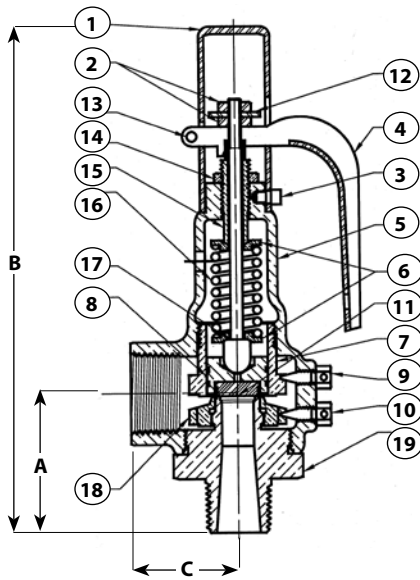

19 SERIES

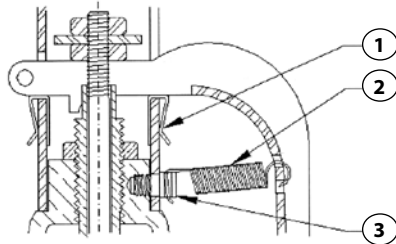

### MATERIALS 19 SERIES WITH OPTION "A" ANTI-VIBRATION TRIM

Item	Component	Material
1	Friction Clip (4)	Steel Plated
2	Extension Spring	Stainless Steel
3	Cap Lock Screw	Stainless Steel

Note: Preparation includes threadlocking of all internal threaded connections.

### MATERIALS

Item	Component	Material 19K, 19M	Material 19L, 19S
1	Cap	Brass	Brass
2	Stem Nut (2)	Steel - Plated	Steel - Plated
3	Cap Lock Screw	Brass	Brass
4	Lift Lever	Steel - Plated	Steel - Plated
5	Body	Bronze	Bronze
6	Spring Washer (2)	Brass	Brass
7	Guide Ring	Brass	Brass
8	Disc	Brass	Stainless Steel
9	Guide Ring Screw	Brass	Brass
10	Nozzle Ring Screw	Brass	Brass
11	Seat Insert-19K & 19L	PFA Teflon®	PFA Teflon®
12	Lift Washer	Steel - Plated	Steel - Plated
13	Lever Pin	Steel - Plated	Steel - Plated
14	Adjusting Screw Lock Nut	Steel - Plated	Steel - Plated
15	Adjusting Screw	Brass	Brass
16	Spring	Stainless Steel	Stainless Steel
17	Stem	Stainless Steel	Stainless Steel
18	Nozzle Ring	Brass	Brass
19	Nozzle	Brass	Stainless Steel
-	Nameplate	Stainless Steel	Stainless Steel
-	Seal and Wire	Lead/SS*	Lead/SS*

\* Alum/SS on CE models

### DIMENSIONS AND WEIGHTS

Old Model Number	New Model Number	Orifice Letter	Size (in./mm) Inlet x Outlet	Dimensions (in./mm.)			Wt./Ea. (lbs./kg.)
				A	B	C	
19-202	19*DC	D	1/2 X 3/4	2.21	6.52	1.37	1.6
			15 x 20	56	166	35	.73
19-301	19*DD	D	3/4 X 3/4	2.21	6.52	1.37	1.6
			20 x 20	56	166	35	.73
19-302	19*ED	E	3/4 X 1	2.50	7.16	1.75	2.0
			20 x 25	64	182	44	.91
19-401	19*EE	E	1 X 1	2.64	7.30	1.75	2.2
			25 x 25	67	185	44	1.0
19-402	19*FE	F	1 X 1-1/4	2.95	9.34	2.00	4.1
			25 x 32	75	237	51	1.9
19-501	19*FF	F	1-1/4 X 1-1/4	2.95	9.34	2.00	4.3
			32 x 32	75	237	51	2.0
19-502	19*GF	G	1-1/4 X 1-1/2	3.38	11.01	2.37	7.4
			32 x 40	86	280	60	3.4
19-601	19*GG	G	1-1/2 X 1-1/2	3.38	11.01	2.37	7.6
			40 x 40	86	280	60	3.4
19-602	19*HG	H	1-1/2 X 2	3.63	11.96	2.75	11.5
			40 x 50	92	304	70	5.2
19-701	19*HH	H	2 X 2	3.63	11.96	2.75	11.6
			50 x 50	92	304	70	5.3
	19*JG <sup>1</sup>	J	1-1/2F X 2-1/2	3.80	14.00	3.50	20.0
			40 x 65	97	356	89	9.1
19-702	19*JH	J	2 X 2-1/2	4.06	14.25	3.50	19.9
			50 x 65	103	362	89	9.0
19-801	19*JJ	J	2-1/2 X 2-1/2	4.50	14.68	3.50	20.8
			65 x 65	114	373	89	9.4

\* Specify trim letter (see previous page):

1: Available in bronze trim only, Model 19KJG & 19MJG.

Connections are 1-1/2" FNPT x 2-1/2" FNPT.