

SAFETY & RELIEF VALVES

OEM Style Steam Safety Relief Valves

10-322 SERIES

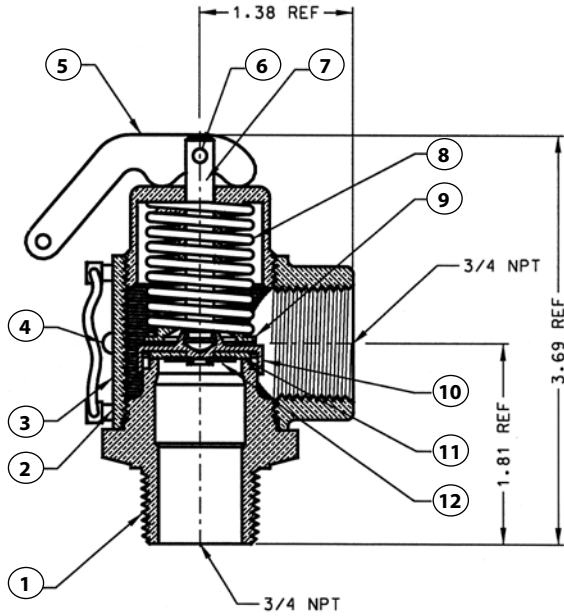

10-322 MATERIALS

Item	Component	Material
1	Nozzle	Brass ASTM B-16
2	Body	Brass ASTM B-16
3	Nameplate	Aluminum
4	Drive Screw	Steel, Zinc Plated
5	Handle	Steel, Zinc Plated
6	Cotter Pin	Steel, Zinc Plated
7	Stem	Brass ASTM B-16
8	Spring	Stainless Steel
9	Spring Washer	Brass ASTM B-16
10	Disc	Brass ASTM B-16
11	Seat	Teflon Faced EPDM
12	Washer	Brass ASTM B-16

10-512 SERIES

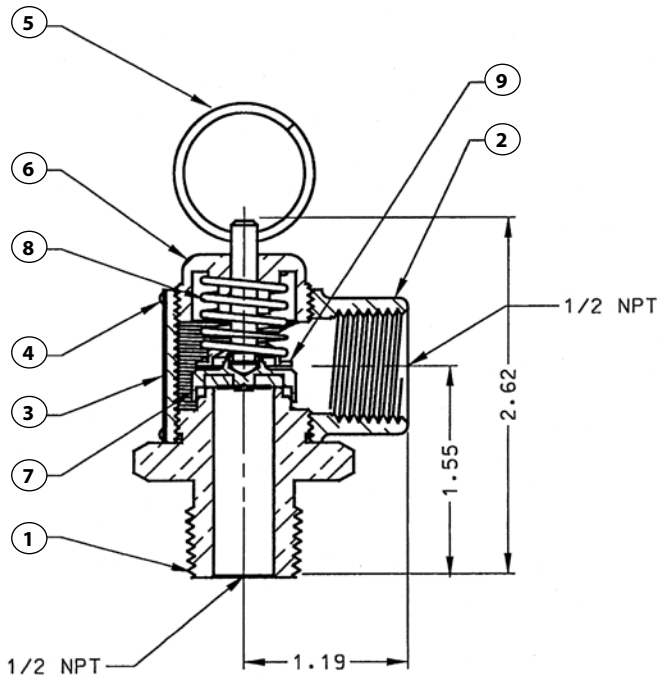

10-512 MATERIALS

Item	Component	Material
1	Nozzle	Brass ASTM B-16
2	Body	Brass ASTM B-16
3	Nameplate	Aluminum
4	Drive Screw	Steel, Zinc Plated
5	Pull Ring	Steel, Zinc Plated
6	Cap	Brass ASTM B-16
7	Disc Assembly	Brass, Silicone
8	Spring	Stainless Steel
9	Spring Washer	Brass ASTM B-16

Model 10-512 available with optional stainless steel wetted trim. Nozzle, disc holder and disc washer are type 316 stainless steel.