

Stainless Steel

Model	WSSCV
Sizes	1/2", 3/4", 1", 1 1/4", 1 1/2", 2", 3"
Connections	NPT, SW
Body Material	316 Stainless Steel
PMO Max. Operating Pressure	500 PSIG
PMA Max. Allowable Pressure	750°F PSIG @ 100°F
TMA Max. Allowable Temperature	850°F @ 420 PSIG

Note: WSSCV with 1/4 PSI cracking pressure is required for all mechanical pump applications. The 5 PSIG cracking pressure version is also available. See model code chart.



Typical Applications

The Model **WSSCV** is an all stainless steel in-line check valve for steam, gas, or liquid service. It provides tight shut-off, minimizes water hammer and also stops recycling of pumps by preventing back flow of liquid. Used in the petrochemical, pulp & paper, textile and food & beverage industries. The WSSCV all stainless steel check valves will operate much longer and are less problematic than bronze or cast iron check valves.

Features & Options

- 316 Stainless Steel Body and Internals
- Low cracking pressure on spring (1/4 PSI) to minimize resistance and maximize flow.
- Available with optional 5 PSI cracking pressure (must specify at time of order)
- Available with NPT, SW, or optional Flanged connections
- Spring made from Inconel-X-750 to handle extreme temperature as well as corrosive applications
- Body is seam-welded to eliminate O-rings or gasket seals which can be affected by high temperature steam or hot condensate
- Spring assisted closing of check valve to minimize noise and wear

Sample Specification

Check valve shall have a 316 stainless steel body and disc. Spring shall be made from Inconel-X-750. Check valve body to be seam welded together to eliminate need for O-ring or gasket.

MATERIALS

Body	316 Stainless Steel
Disc	316 Stainless Steel
Spring	Inconel-X-750

NPT

Size/Connection NPT	Model Code	Cracking Pressure* PSI	Weight lbs
1/2"	WSSCV-12-N-0	0.25	1.0
3/4"	WSSCV-13-N-0	0.25	1.5
1"	WSSCV-14-N-0	0.25	2.3
1 1/4"	WSSCV-15-N-0	0.25	3.5
1 1/2"	WSSCV-16-N-0	0.25	5.3
1 1/2"	WSSCVQF-16-N-0†	0.00	5.3
2"	WSSCV-17-N-0	0.25	8.5
3"	WSSCV-19-N-0	0.25	21
1/2"	WSSCV-12-N-5	5.0	1.0
3/4"	WSSCV-13-N-5	5.0	1.5
1"	WSSCV-14-N-5	5.0	2.3
1 1/4"	WSSCV-15-N-5	5.0	3.5
1 1/2"	WSSCV-16-N-5	5.0	5.3
2"	WSSCV-17-N-5	5.0	8.5
3"	WSSCV-19-N-5	5.0	21

Socket Weld

Size/Connection SW	Model Code	Cracking Pressure* PSI	Weight lbs
1/2"	WSSCV-12-SW-0	0.25	1.0
3/4"	WSSCV-13-SW-0	0.25	1.5
1"	WSSCV-14-SW-0	0.25	2.3
1 1/4"	WSSCV-15-SW-0	0.25	3.5
1 1/2"	WSSCV-16-SW-0	0.25	5.3
2"	WSSCV-17-SW-0	0.25	8.5
3"	WSSCV-19-SW-0	0.25	21
1/2"	WSSCV-12-SW-5	5.0	1.0
3/4"	WSSCV-13-SW-5	5.0	1.5
1"	WSSCV-14-SW-5	5.0	2.3
1 1/4"	WSSCV-15-SW-5	5.0	3.5
1 1/2"	WSSCV-16-SW-5	5.0	5.3
2"	WSSCV-17-SW-5	5.0	8.5
3"	WSSCV-19-SW-5	5.0	21

* Differential Pressure at which valve opens and flow occurs.

† WSSCVQF is a special design check valve for use on the inlet side of the PMPT & PMPNT Pumps. It is center-guided and contains no spring. Used for increasing fill rate of pump.

Stainless Steel

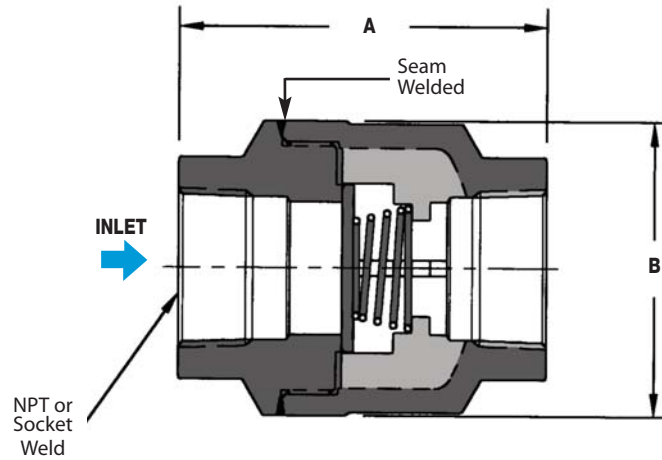

DIMENSIONS & SPECIFICATIONS – inches							
Size	1/2"	3/4"	1"	1 1/4"	1 1/2"	2"	3"
MODEL CODE	WSSCV-12	WSSCV-13	WSSCV-14	WSSCV-15	WSSCV-16	WSSCV-17	WSSCV-19
A	2.69	3.00	3.32	3.81	4.75	5.03	6.87
B	1.62	2.12	2.56	3.06	3.44	4.38	6.19
Weight (lbs)	1.1	1.5	1.9	3.8	4.7	7.7	18.8
Standard Cracking Pressure*	0.25	0.25	0.25	0.25	0.25	0.25	0.25
Optional Cracking Pressure*	5.0	5.0	5.0	5.0	5.0	5.0	5.0
Cv	7	13	22	39	54	93	180

* Note: Differential Pressure at which valve opens and flow occurs (PSI).

WSSCV Check Valve Construction

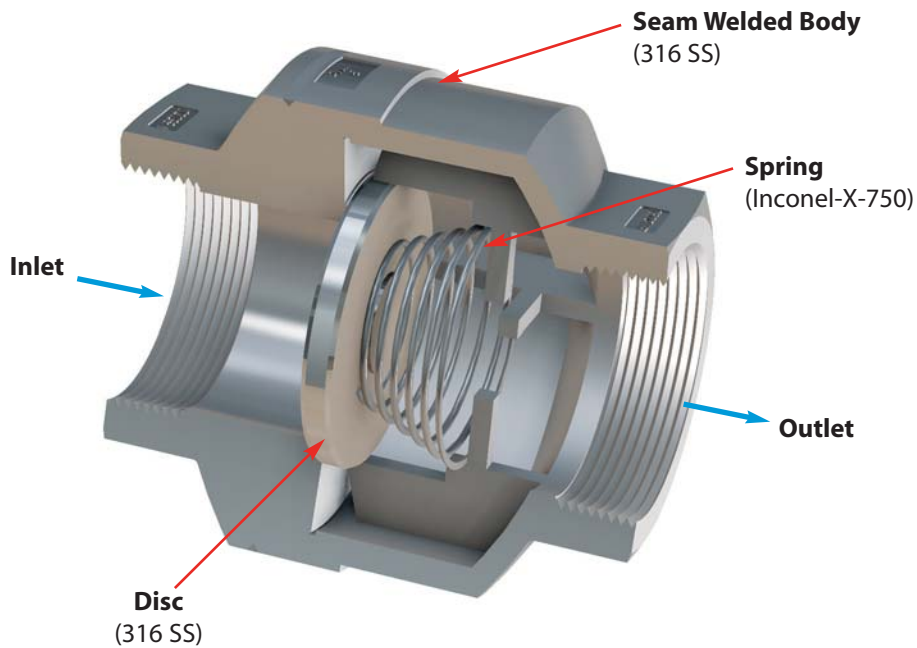

“UV” Steam-ASME Section VIII Pressure Vessels

Model	SVB
Sizes	1/2", 3/4", 1", 1 1/4", 1 1/2", 2", 2 1/2"
Connections	NPT
Body Material	Bronze
PMO Max. Operating Pressure	250 PSIG (steam)
TMO Max. Operating Temperature	406 °F

Typical Applications

The **SVB** Safety Valves are used for over-pressure protection on unfired pressure vessels in saturated steam systems. Valves are 100% factory tested and made in the USA.

How It Works

In the event steam pressure increases to the set point, the safety valve will “pop open” discharging steam faster than it can be produced; allowing system pressure to return to safe levels at which point the valve will close.

Features

- Stainless Steel springs
- Teflon®-PFA seat resists corrosive boiler chemicals
- Two control rings for maximum performance and adjustability
- Tapped body drain allows piping of condensate away from valve to protect the internals from fouling

Sample Specification

Safety valves shall be cast bronze construction with stainless steel springs, Teflon-PFA seats and stainless steel stems. Units shall be qualified to the ASME Boiler Code, Section VIII and suitable for steam service.

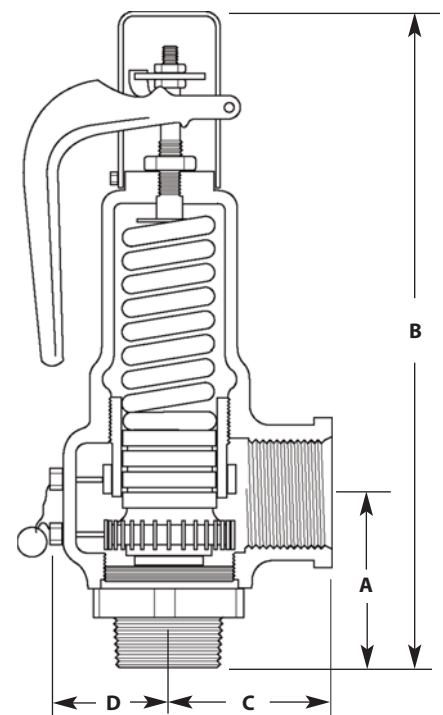

MATERIALS

Body	Bronze
Guide Ring	Brass
Disc	Brass
Seat Insert	Teflon®-PFA
Stem	Stainless Steel

DIMENSIONS & WEIGHTS — inches

Model Code	Orifice Size	Inlet x Outlet MNPT x FNPT	A	B	C	D	Weight (lbs)
SVB-12M-13S-D	D	1/2" x 3/4"	2.21	6.52	1.37	0.84	1.6
SVB-13M-13S-D	D	3/4" x 3/4"	2.21	6.52	1.37	0.84	1.6
SVB-13M-14S-E	E	3/4" x 1"	2.50	7.16	1.75	1.06	2.0
SVB-14M-14S-E	E	1" x 1"	2.64	7.30	1.75	1.06	2.2
SVB-14M-15S-F	F	1" x 1 1/4"	2.95	9.34	2.00	1.44	4.1
SVB-15M-15S-F	F	1 1/4" x 1 1/4"	2.95	9.34	2.00	1.44	4.3
SVB-15M-16S-G	G	1 1/4" x 1 1/2"	3.38	11.01	2.37	1.69	7.4
SVB-16M-16S-G	G	1 1/2" x 1 1/2"	3.38	11.01	2.37	1.69	7.6
SVB-16M-17S-H	H	1 1/2" x 2"	3.63	11.96	2.75	2.06	11.5
SVB-17M-17S-H	H	2" x 2"	3.63	11.96	2.75	2.06	11.6
SVB-16S-18S-J	J	1 1/2" FNPT x 2 1/2" FNPT	3.80	14.00	3.50	2.06	20.0
SVB-17M-18S-J	J	2" x 2 1/2"	4.06	14.25	3.50	2.06	19.9
SVB-18M-18S-J	J	2 1/2" x 2 1/2"	4.50	14.68	3.50	2.06	20.8

“UV” Steam-ASME Section VIII Pressure Vessels

CAPACITIES – Pounds of saturated steam per hour (lbs/hr)						
Set Pressure (PSIG)	Orifice “D” .129” Diameter	Orifice “E” .230” Diameter	Orifice “F” .359” Diameter	Orifice “G” .586” Diameter	Orifice “H” .919” Diameter	Orifice “J” 1.509” Diameter
15	179	320	499	820	1279	2100
20	207	369	576	945	1474	2421
25	234	418	652	1070	1670	2742
30	262	467	729	1195	1865	3063
35	292	521	813	1333	2080	3416
40	322	574	897	1471	2295	3769
45	352	628	981	1609	2510	4122
50	383	682	1065	1747	2725	4475
55	413	736	1149	1885	2941	4828
60	443	790	1233	2022	3156	5181
65	473	844	1317	2160	3371	5535
70	503	897	1401	2298	3586	5888
75	534	951	1485	2436	3801	6241
80	564	1005	1569	2574	4016	6594
85	594	1059	1653	2712	4231	6947
90	624	1113	1737	2849	4446	7300
95	654	1167	1821	2987	4661	7653
100	684	1220	1905	3125	4876	8007
105	715	1274	1989	3263	5091	8360
110	745	1328	2073	3401	5306	8713
115	775	1382	2157	3539	5521	9066
120	805	1436	2241	3677	5736	9419
125	835	1489	2325	3814	5951	9772
130	866	1543	2409	3952	6167	10125
135	896	1597	2493	4090	6382	10479
140	926	1651	2577	4228	6597	10832
145	956	1705	2661	4366	6812	11185
150	986	1759	2745	4504	7027	11538
155	1017	1812	2829	4641	7242	11891
160	1047	1866	2913	4779	7457	12244
165	1077	1920	2997	4917	7672	12597
170	1107	1973	3081	5055	7887	12951
180	1167	2081	3249	5331	8317	13657
190	1228	2189	3417	5606	8747	14363
200	1288	2296	3585	5882	9177	15069
210	1349	2404	3753	6158	9608	15776
220	1409	2512	3921	6433	10038	16482
230	1469	2619	4089	6709	10468	17188
240	1530	2727	4257	6985	10898	17894
250	1590	2834	4425	7260	11328	18601
Approx. 1 PSI Incr.	6.0	10.8	16.8	27.6	43.0	70.6

Notes: 1) Ratings are 90% of actual capacity.
2) For Set Pressures over 250 PSIG, consult factory.
3) For other sizes, consult factory.

“UV” Steam-ASME Section VIII Pressure Vessels

Model	SVI
Sizes	1½", 2", 2½", 3", 4", 6"
Connections	NPT, FLG
Body Material	Cast Iron
PMO Max. Operating Pressure	250 PSIG (Steam)
TMO Max. Operating Temperature	422° F

Typical Applications

The SVI Safety Valves are used for over-pressure protection on unfired pressure vessels in saturated steam systems. Valves are 100% factory tested and made in the USA.

How It Works

In the event steam pressure increases to the set point, the safety valve will “pop open” discharging steam faster than it can be produced; allowing system pressure to return to safe levels at which point the valve will close.

Features

- Stainless Steel wetted trim nozzle & disc
- Metal to metal seating, lapped to optimum flatness
- Tapped body drain allows piping of condensate away from valve to protect the internals from fouling
- Two control rings assure maximum performance and adjustability

Sample Specification

Safety valves shall be high capacity design with cast iron construction featuring rust-proof stainless steel stems, springs, washers and metal-to-metal lapped seats. Units shall be qualified to the ASME Boiler Code Section VIII and suitable for steam service.

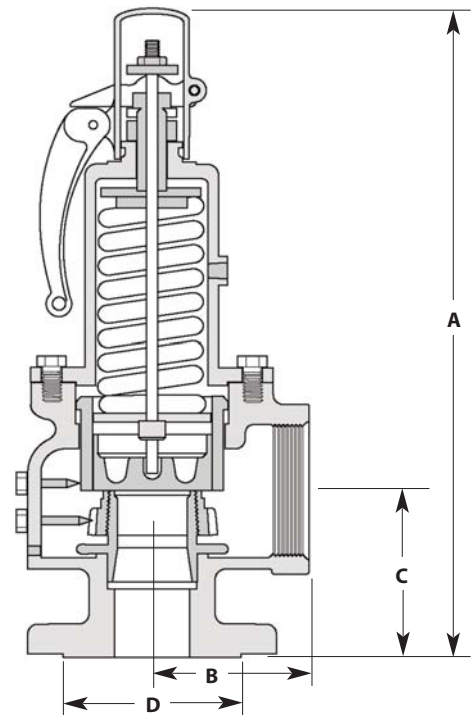

DIMENSIONS & WEIGHTS – inches

Model Code	Valve Size Inlet x Outlet	Orifice Size	A	B	C	Hex Flat D	Weight (lbs)
SVI-16F-18S-J	1½" 250#FLG x 2½" FNPT	J	15	4	4.31		35
SVI-17F-19S-K	2" 250#FLG x 3" FNPT	K	16	4	4.63		36
SVI-17S-19S-K	2" FNPT x 3" FNPT	K	16	4	4.63	3.75	37
SVI-18F-19S-K	2½" 250#FLG x 3" FNPT	K	16	4	4.63		41
SVI-19F-19S-K	3" 250#FLG x 3" FNPT	K	16	4	4.63		45
SVI-18F-20S-L	2½" 250#FLG x 4" FNPT	L	22	5.13	5.63		84
SVI-18S-20S-L	2½" FNPT x 4" FNPT	L	22	5.13	5.63	5.38	81
SVI-19F-20S-L	3" 250#FLG x 4" FNPT	L	22	5.13	5.63		85
SVI-20F-20S-L	4" 250#FLG x 4" FNPT	L	22	5.13	5.63		90
SVI-19S-20S-M	3" FNPT x 4" FNPT	M	22	5.13	5.63	5.38	80
SVI-19F-20S-M	3" 250#FLG x 4" FNPT	M	22	5.13	5.63		87
SVI-20F-20S-M	4" 250#FLG x 4" FNPT	M	22	5.13	5.63		95
SVI-20F-22F-N	4" 250#FLG x 6" 125#FLG	N	28	7.25	6.75		210
SVI-20F-22F-P	4" 250#FLG x 6" 125#FLG	P	28	7.25	6.75		215
SVI-22F-23F-Q	6" 250#FLG x 8" 125#FLG	Q	42	10	9.25		530
SVI-22F-23F-R	6" 250#FLG x 8" 125#FLG	R	42	10	9.25		530

MATERIALS

Body	Cast Iron
Guide Ring	Brass
Disc	Stainless Steel
Stem	Stainless Steel

"UV" Steam-ASME Section VIII Pressure Vessels

CAPACITIES – Pounds of saturated steam per hour (lbs/hr)								
Set Pressure (PSIG)	Orifice Letter / Area in Square Inches							
	"J" = 1.358	"K" = 1.926	"L" = 2.990	"M" = 3.774	"N" = 4.550	"P" = 6.692	"Q" = 11.593	"R" = 16.798
15	2008	2848	4421	5580	6728	9895	17141	24820
20	2315	3283	5097	6433	7756	11408	19762	28615
25	2622	3719	5773	7287	8785	12921	22383	32410
30	2929	4154	6449	8140	9814	14434	25004	36205
35	3267	4633	7193	9079	10945	16098	27887	40379
40	3604	5112	7936	10017	12077	17762	30771	44554
45	3942	5591	8680	10956	13208	19426	33654	48729
50	4280	6070	9423	11894	14340	21091	36537	52903
55	4618	6549	10167	12833	15471	22755	39420	57078
60	4955	7028	10911	13771	16603	24419	42303	61252
65	5293	7507	11654	14710	17735	26083	45186	65427
70	5631	7986	12398	15649	18866	27748	48069	69601
75	5969	8465	13141	16587	19998	29412	50952	73776
80	6306	8944	13885	17526	21129	31076	53835	77951
85	6644	9423	14629	18464	22261	32740	56719	82125
90	6982	9902	15372	19403	23392	34405	59602	86300
95	7319	10381	16116	20341	24524	36069	62485	90474
100	7657	10860	16859	21280	25655	37733	65368	94649
105	7995	11339	17603	22218	26787	39397	68251	98823
110	8333	11818	18346	23157	27919	41062	71134	102998
115	8670	12297	19090	24096	29050	42726	74017	107173
120	9008	12776	19834	25034	30182	44390	76900	111347
125	9346	13255	20577	25973	31313	46055	79783	115522
130	9684	13734	21321	26911	32445	47719	82666	119696
135	10021	14213	22064	27850	33576	49383	85550	123871
140	10359	14692	22808	28788	34708	51047	88433	128045
145	10697	15171	23552	29727	35839	52712	91316	132220
150	11034	15650	24295	30666	36971	54376	94199	136395
155	11372	16129	25039	31604	38103	56040	97082	140569
160	11710	16608	25782	32543	39234	57704	99965	144744
165	12048	17087	26526	33481	40366	59369	102848	148918
170	12385	17566	27270	34420	41497	61033	105731	153093
175	12723	18045	28013	35358	42629	62697	108614	157267
180	13061	18524	28757	36297	43760	64361	111497	161442
185	13399	19003	29500	37236	44892	66026	114381	165617
190	13736	19482	30244	38174	46023	67690	117264	169791
195	14074	19961	30988	39113	47155	69354	120147	173966
200	14412	20440	31731	40051	48287	71018	123030	178140
205	14749	20919	32475	40990	49418	72683	125913	182315
210	15087	21398	33218	41928	50550	74347	128796	186489
215	15425	21876	33962	42867	51681	76011	131679	190664
220	15763	22355	34706	43806	52813	77675	134562	194839
225	16100	22834	35449	44744	53944	79340	137445	199013
230	16438	23313	36193	45683	55076	81004	140329	203188
235	16776	23792	36936	46621	56207	82668	143212	207362
240	17113	24271	37680	47560	57339	84332	146095	211537
245	17451	24750	38424	48498	58471	85997	148978	215711
250	17789	25229	39167	49437	59602	87661	151861	219886
Approx. 1 PSI incr.	68	96	149	188	226	333	577	835

Notes: 1) Ratings are 90% of actual capacity. 2) For Set Pressures over 250 PSIG, consult factory. 3) For other sizes, consult factory.
4) ASME Section I – Steam Boilers – pounds of saturated steam per hour @ 3% or 2 PSIG accumulation (whichever is greater).
5) ASME Section VIII – Pressure Vessels – pounds of saturated steam per hour @ 10 % or 3 PSIG accumulation (whichever is greater).

PIPELINE ACCESSORIES

Drip Pan Elbow

Cast Iron

Model	DPL
Sizes	3/4" through 8"
Connections	NPT, FLG
Body Material	Cast Iron
PMO Max. Operating Pressure	250 PSIG

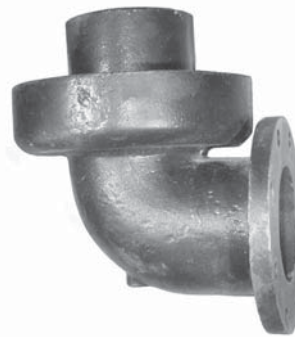

DPL Flanged

Typical Applications

The DPL Drip Pan Elbow is used to collect and remove condensate. Typically used with steam boilers, pressure relief valves, safety valves and steam pressure vessels and lines.

Features

- Collects discharge condensate from steam systems
- Returns condensate to safe areas
- Increases life of safety valves
- Reduces discharge piping strain
- Female NPT or Flanged connections available

Sample Specification

Drip Pan Elbow shall be made of cast iron and conform to the Power Piping Code. It shall have a pan to collect condensate in the steam riser pipe and a drain to pipe away the condensate.

HOW TO ORDER

Specify pipe size needed for application.

MATERIALS

Body	Cast Iron
------	-----------

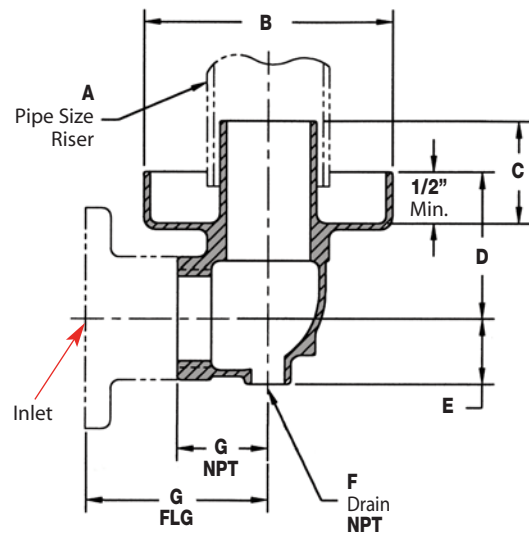

DIMENSIONS & WEIGHTS – inches

Size	Connection	Model Code	A	B	C	D	E	F	G	Weight (lbs)
3/4"	NPT	DPL-13-N	1 1/2	3 3/4	1 3/4	2 3/4	1 1/32	1/4	1 1/2	2
1"	NPT	DPL-14-N	1 1/2	3 3/4	1 3/4	2 3/4	1 1/32	1/4	1 1/2	2
1 1/4"	NPT	DPL-15-N	2	5 1/2	2 15/32	4 1/8	1 7/16	3/8	2 1/8	8
1 1/2"	NPT	DPL-16-N	2	5 1/2	2 15/32	4 1/8	1 7/16	3/8	2 1/8	8
2"	NPT	DPL-17-N	3	6 1/4	2 3/8	3 5/8	1 5/8	1/2	2 1/4	9
2 1/2"	NPT	DPL-18-N	4	7 3/8	3	4 5/16	1 15/16	3/4	2 11/16	13
3"	NPT	DPL-19-N	4	8	3 1/2	4 7/8	2 5/16	3/4	3 1/8	19
4"	NPT	DPL-20-N	6	9 5/8	4 1/2	5 3/4	2 7/8	3/4	3 3/4	28
6"	125# FLG	DPL-22-F125	8	12 3/4	6 5/8	7 9/16	4 3/16	3/4	8	105
8"	125# FLG	DPL-23-F125	10	16 1/2	7 1/2	8 9/16	5 3/8	1	10 3/4	202

Note: DPL is sized to outlet connection of SRV (safety relief valve).

PIPELINE ACCESSORIES

Carbon Steel

Model	WFLV
Sizes	6", 8", 12", 16"
Connections	150# RF
Body Material	Carbon Steel
PMO Max. Operating Pressure	150 PSIG
TMO Max. Operating Temperature	366°F
PMA Max. Allowable Pressure	150 PSIG @ 562°F

Note: 250 PSIG unit available. Consult factory.

Typical Applications

The WFLV Flash tanks are installed in condensate return systems to separate off flash steam from hot condensate and neutralize pressure in condensate return lines. The flash steam may be used for low pressure heating applications or vented to atmosphere.

How to Size / Order

Use Table 1 to determine amount of Flash Steam that will be generated by the hot pressurized condensate. The percentage of Flash Steam formed is found where Condensate Pressure and Flash Tank Pressure intersect.

Multiply your Condensate Load by the decimal equivalent of the Flash Steam Percent to determine the amount of Flash Steam in lbs/hr. Then, use Figure 1 to determine Flash Tank Size required:

Example: Condensate Pressure: 100 PSIG
Flash Tank Pressure: 20 PSIG
Condensate Load: 8,000 lbs/hr
% Flash Steam: 8.7% from chart
Decimal Equivalent % Flash Steam = .087

$.087 \times 8000 = 696 \text{ lbs/hr of flash steam}$

Therefore Choose: 12" FLASH TANK

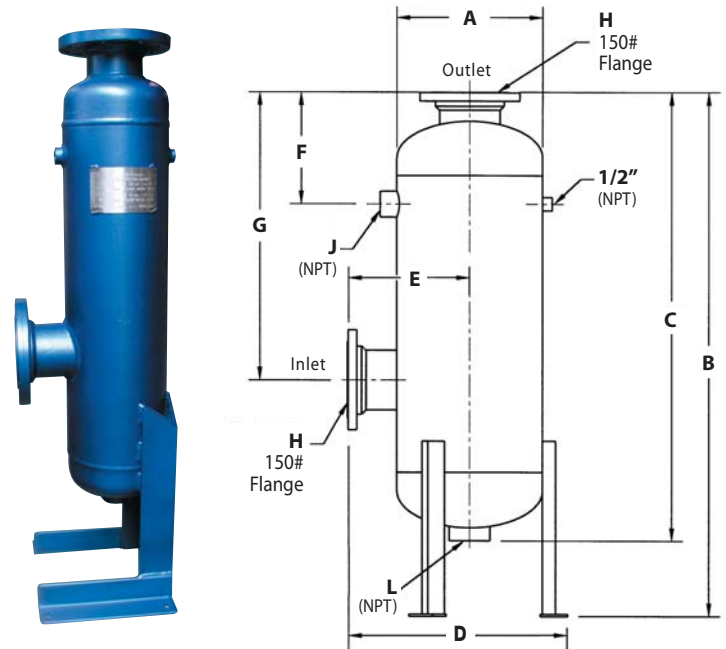
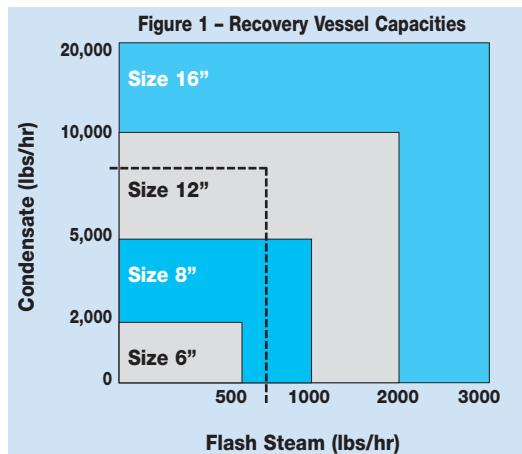

Note: All Watson McDaniel flash steam recovery vessels are supplied with ASME Section VIII Code Stamp.

Condensate Pressure (PSIG)	Flash Tank Pressure (PSIG)									
	0	5	10	20	30	40	60	80	100	
5	1.6	0.0								
10	2.9	1.3	0.0							
15	3.9	2.4	1.1							
20	4.9	3.3	2.1	0.0						
30	6.5	5.0	3.7	1.7	0.0					
40	7.8	6.3	5.1	3.0	1.4	0.0				
60	10.0	8.5	7.3	5.3	3.7	2.3	0.0			
80	11.8	10.3	9.1	7.1	5.5	4.2	1.9	0.0		
100	13.3	11.8	10.6	8.7	7.1	5.8	3.5	1.6	0.0	
125	14.9	13.5	12.3	10.4	8.8	7.5	5.3	3.4	1.8	
150	16.3	14.9	13.7	11.8	10.3	9.0	6.8	4.9	3.3	
200	18.7	17.3	16.2	14.3	12.8	11.5	9.4	7.6	6.0	
250	20.8	19.4	18.2	16.4	14.9	13.7	11.5	9.8	8.2	
300	22.5	21.2	20.0	18.2	16.8	15.5	13.4	11.7	10.2	
350	24.1	22.8	21.7	19.9	18.4	17.2	15.1	13.4	11.9	
400	25.6	24.2	23.1	21.4	19.9	18.7	16.7	15.0	13.5	

Tank Diameter	Model Code	Side In/Top Out 150#FLG (H)	A	B	C	D	E	F	G	J	L	Weight (lbs)
6"	WFLV-6-18-F150	2 1/2"	6 5/8	47	38 1/2	12	8	9	25 1/2	3/4	1 1/2	105
8"	WFLV-8-20-F150	4"	8 5/8	48	39 3/4	13	8 1/2	9 1/2	25 5/8	3/4	2	172
12"	WFLV-12-21-F150	5"	12 3/4	49 1/2	41 1/4	21	11 3/4	11 1/2	26	1 1/2	3	210
16"	WFLV-16-22-F150	6"	16	58	50	24	13 3/8	12 1/2	32	2	3	300

Cast Iron, Carbon Steel & Stainless Steel

Model	EHC	EHF	EHFSS
Sizes	1", 1 1/2", 2", 2 1/2", 3", 4", 5", 6", 8", 10"	2, 2 1/2", 3", 4", 5", 6", 8", 10"	
Connections	NPT, 125# FLG	150# FLG	
Body Material	Cast Iron	Carbon Steel	Stainless Steel

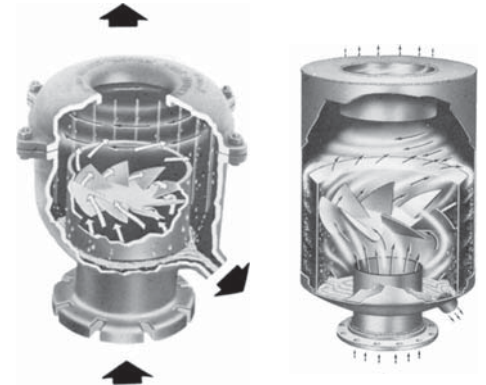

Typical Applications

Exhaust Heads are used to separate entrained water from flash steam prior to being discharged or vented to the atmosphere. Typically used to eliminate water damage to rooftops and other equipment.

How It Works

Exhaust heads use the cyclonic effect where the velocity of the steam is used to generate centrifugal motion that whirls the steam and throws the entrained water to the wall of the unit where it is released to a drain below. Correct sizing of exhaust heads for steam service is important in order to assure the highest possible desiccation of the steam.

Sample Specification

Exhaust Head shall be a cyclone design for vertical venting to atmosphere. Unit shall have a vortex containment plate feature to prevent re-entrainment of liquid. Exhaust Head to be constructed in cast iron, carbon steel or stainless steel and available in FNPT and flanged connections.

Installation

Exhaust Head must be installed at the top of a vertical vent pipe. Exercise standard piping and structural practices when installing this unit. Proper drainage of the exhaust head is essential for proper operation. Pipe the drain Connection of the exhaust head to a roof gutter or down spout.

Exhaust Head Use:

The EHC Series Exhaust Heads are used to separate entrained water from flash steam prior to being vented to the atmosphere. Typically used to eliminate water damage to rooftops and other equipment.

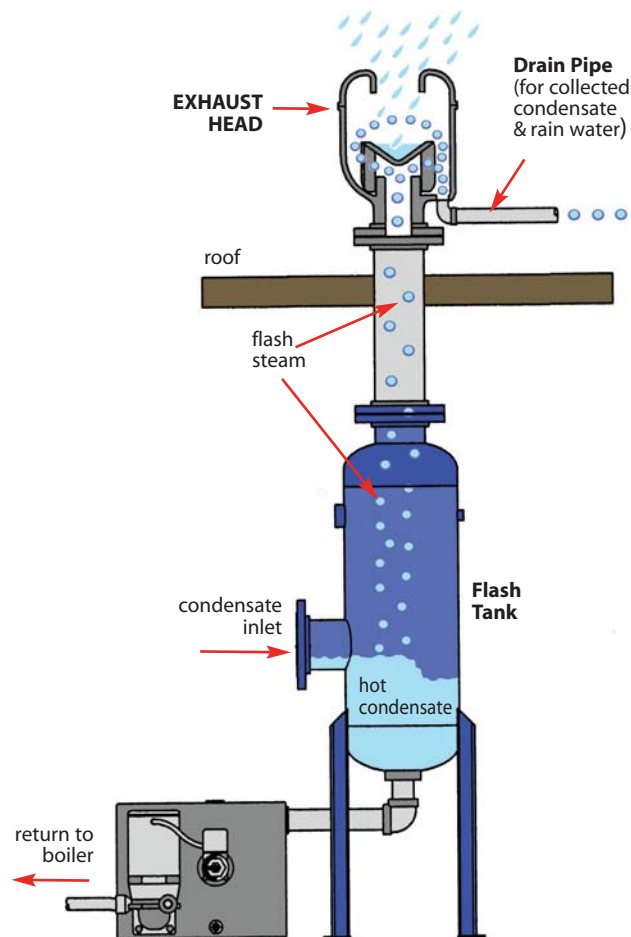

Cast Iron, Carbon Steel & Stainless Steel



EHC (Cast Iron)

EHC DIMENSIONS (Inches), CAPACITIES (lbs/hr)							
Inlet Size	Inlet Connection	Model Code (Cast Iron)	A	B	Drain NPT	Weight (lbs)	Capacity*
1"	NPT	EHC14-N	5 ¹ / ₄	6 ¹ / ₈	1/2	12	160
1 ¹ / ₂ "	NPT	EHC16-N	5 ¹ / ₄	6 ¹ / ₈	1/2	12	370
2"	NPT	EHC17-N	7 ¹ / ₂	8 ⁷ / ₈	3/4	32	1,000
2 ¹ / ₂ "	NPT	EHC18-N	7 ¹ / ₂	8 ⁷ / ₈	3/4	32	1,000
3"	NPT	EHC19-N	8 ³ / ₄	11 ¹ / ₄	3/4	50	2,100
4"	NPT	EHC20-N	10	11 ⁷ / ₈	1	50	2,700
3"	125# FLG	EHC19-F125	8 ³ / ₄	15	3/4	60	2,700
4"	125# FLG	EHC20-F125	10	15	1	82	2,700
5"	125# FLG	EHC21-F125	13	14	1 ¹ / ₂	90	4,000
6"	125# FLG	EHC22-F125	14 ³ / ₄	18 ³ / ₄	1 ¹ / ₂	137	6,000
8"	125# FLG	EHC23-F125	18	20	2	170	10,500
10"	125# FLG	EHC24-F125	23	24	2	335	16,000

* Capacity in pounds of exhaust steam per hour at atmospheric pressure of 14.7 PSIA.
Note: For Stainless Steel versions replace EHF with EHFSS in model code. Example: EHFSS17-150

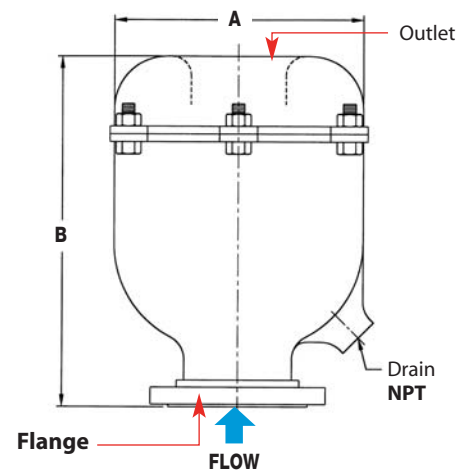
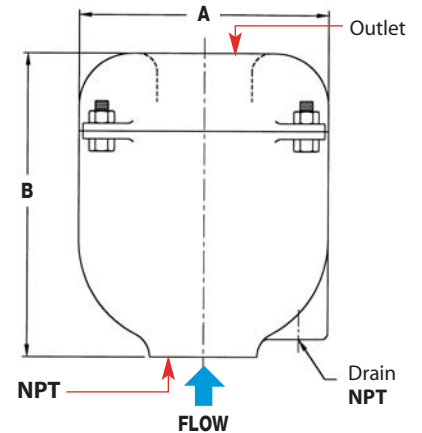

EHF (Carbon Steel) & EHFSS (Stainless Steel)

EHF & EHFSS DIMENSIONS (Inches) & CAPACITIES (lbs/hr)							
Inlet Size	Inlet Connection	Model Code (Carbon Steel)	A	B	Drain NPT	Weight (lbs)	Capacity*
2"	150# FLG	EHF17-F150	8 ⁵ / ₈	16	1	95	1,000
2 ¹ / ₂ "	150# FLG	EHF18-F150	8 ⁵ / ₈	16	1	110	1,000
3"	150# FLG	EHF19-F150	10 ³ / ₄	19	1 ¹ / ₂	115	1,600
4"	150# FLG	EHF20-F150	14	24	1 ¹ / ₂	125	2,700
5"	150# FLG	EHF21-F150	16	26	1 ¹ / ₂	145	4,000
6"	150# FLG	EHF22-F150	18	30	1 ¹ / ₂	177	6,000
8"	150# FLG	EHF23-F150	20	36	2	320	10,500
10"	150# FLG	EHF24-F150	24	42	2	340	16,000

* Capacity in pounds of exhaust steam per hour at atmospheric pressure of 14.7 PSIA.

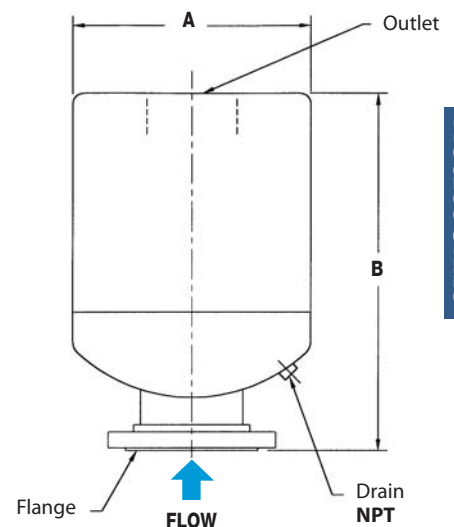

PIPELINE
ACCESSORIES

Why Are Air Vents & Vacuum Breakers Needed?

Air Discharging on Start-Up

(Air Vent Open)

On start-up, the steam jacketed kettle is filled with air which must first be discharged by the Air Vents to allow steam to enter for heating. Float & Thermostatic steam traps contain a separate thermostatic vent; however, additional air vents should be installed on the kettle or air will be trapped. The faster air is expelled, the faster steam can enter and heating can begin.

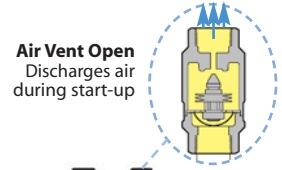

Air Vent Open
Discharges air during start-up

AV2000

Air Vents are installed at the end of steam mains as well as other high points in the system. Temperature sensitive Air Vent is **OPEN** when cooler air is present and **CLOSED** when hot steam enters the system.

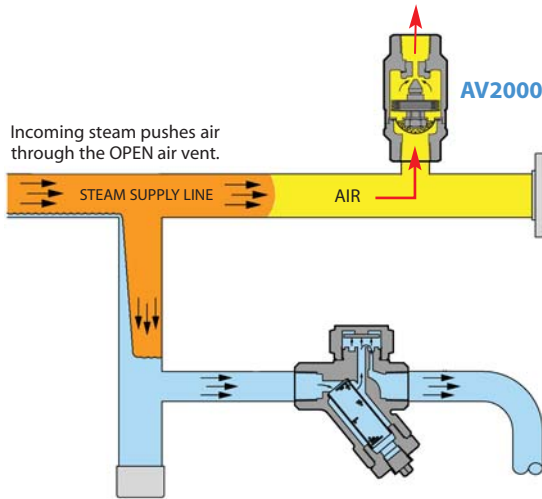

Incoming steam pushes air through the OPEN air vent.

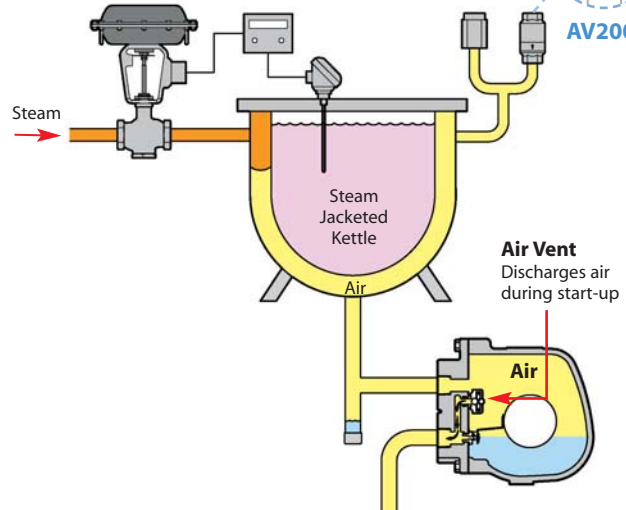

Air Vent
Discharges air during start-up

WVBSS

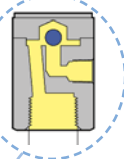

Vacuum Breaker OPEN

Vacuum breaker equalizes jacket pressure to atmospheric pressure (0 psig) and allows head pressure to "push" condensate through the steam trap

Temperature Set Point is Reached

Steam Flow is significantly Reduced after the Temperature Set Point is reached

Once the set temperature is achieved, only a small amount of steam is required to maintain the temperature of the product inside the jacketed kettle. The steam supply valve will modulate to a near shut-off condition, dropping the pressure, and the kettle will then be operating in vacuum. This action will impede the discharge of condensate as the pressure in the jacket will be less than atmospheric. Therefore, a vacuum breaker is required to allow air to enter the jacket and equalize the pressure. This then allows drainage of condensate through the steam trap by gravity. If the vertical discharge leg from the jacket is 2.3 ft., this will provide 1 psi head pressure to assist with condensate drainage.

System with Vacuum Breaker

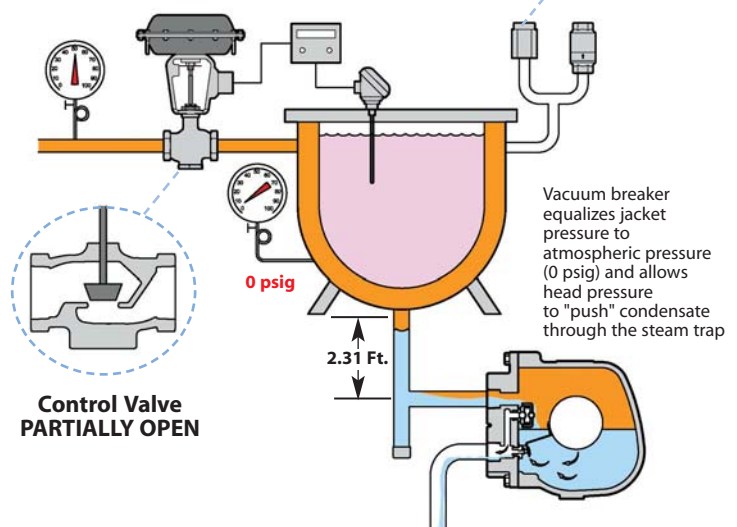

Control Valve PARTIALLY OPEN

Stainless Steel

Model Code	WVBSS-12-N
Sizes	1/2"
Connections	NPT
Body Material	Stainless Steel
PMO Max. Operating Pressure	300 PSIG
TMO Max. Operating Temperature	752°F
PMA Max. Allowable Pressure	300 PSIG up to 752°F
TMA Max. Allowable Temperature	752°F @ 300 PSIG



Typical Applications

The **WVBSS** Vacuum Breaker is used on heat exchangers, air coils, jacketed kettles, pressing machines, boiler feed water tanks, sparge systems, water lines, or anywhere else an unwanted vacuum may occur. The WVBSS allows air to enter the steam or liquid system in order to "break the vacuum" caused by the condensing of steam or draining of liquid from a system. The elimination of vacuum is necessary to allow proper drainage of liquid from process systems.

How It Works

The Vacuum Breaker functions like a simple check valve. Outside air is allowed to enter the system through the air inlet. However, when steam or water try to escape, the vacuum breaker closes off tightly.

Features

- All stainless steel construction
- Small and compact

Sample Specification

Vacuum Breaker shall be all stainless steel construction.

Installation

Unit must be installed in a vertical position and should be placed at the highest point in the system.

MATERIALS

Body	Stainless Steel, Series 300
Ball	Hardened Stainless Steel
Nameplate	Stainless Steel, Series 300

DIMENSIONS – inches

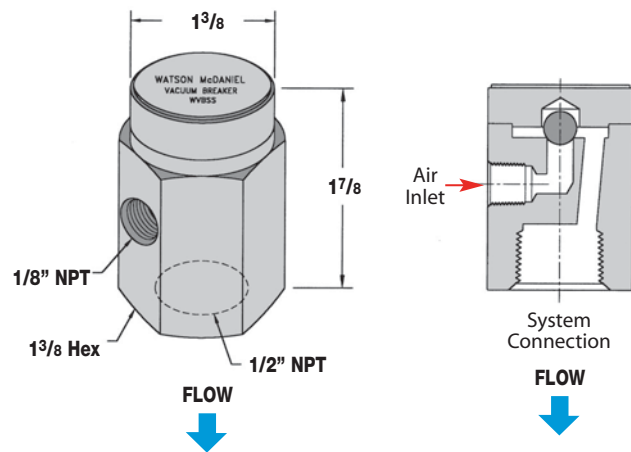

CAPACITIES – Air (SCFM)

Size NPT	inches Hg Vacuum					
	2	4	6	8	10	12
1/2"	2.4	3.4	4.0	4.3	4.7	4.9

PIPELINE
 ACCESSORIES

Air Vent

Thermostatic Air Vent

Model	AVT125
Sizes	1/2", 3/4"
Connections	NPT
Body Material	Forged Brass
PMO Max. Operating Pressure	125 PSIG
TMO Max. Operating Temperature	353°F
PMA Max. Allowable Pressure	125 PSIG up to 450°F
TMA Max. Allowable Temperature	450°F @ 125 PSIG



Air Vents are used for Removing Air from Steam Systems

Typical Applications

The **AVT125** is used on steam applications up to 125 PSIG for removal of air and non-condensable gases from process equipment, vessels and piping. The air vent should be located at a high point in the system or vessel and can be installed in any orientation.

How It Works

The thermostatic air vent contains a welded stainless steel thermal element that expands when heated and contracts when cooled. When air and non-condensable gases are present, the valve is in the open discharge position. When steam reaches the air vent, the element expands and closes the valve off tightly.

Features

- Simple design for easy maintenance
- All Stainless Steel Internals
- Thermal element is the only moving part

Sample Specification

Air vent shall have a stainless steel thermal element with forged brass construction, featuring a union nipple inlet connection. The valve and seat shall be stainless steel.

Installation & Maintenance

Air vents should be located at a high point in the system or vessel. The air vent can be installed in any orientation. An isolation valve should be installed to facilitate repair without system shut-down. Unit is in-line repairable. Repair kits are available.

Size/Connection	Model Code	Orifice Size	PMO PSI	Weight lbs
1/2"	AVT125-12-N	1/4"	125	1.5
3/4"	AVT125-13-N	5/16"	125	1.5

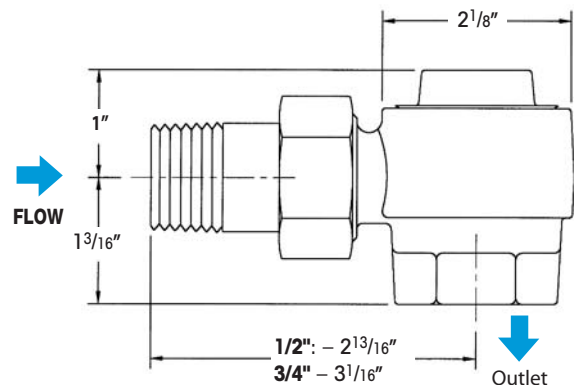

MATERIALS	
Body & Cover	Forged Brass, CA 377
Element	Welded Stainless Steel, AISI 302
Spring	Stainless Steel, AISI 304
Seat	Stainless Steel, AISI 303
Gasket	Brass, ASTM B-21
Union Nipple	Brass, ASTM B-16
Union Nut	Brass, ASTM B-16

CAPACITIES – Air (SCFM)							
Size	Orifice Size	Inlet Pressure (PSIG)					
		5	10	25	50	100	125
1/2"	1/4"	9	13	22	37	65	80
3/4"	5/16"	12	16	27	46	82	100

Thermostatic Air Vent

Model	AV2000 Series
Sizes	1/2", 3/4"
Connections	NPT
Body Material	Stainless Steel
PMO Max. Operating Pressure	650 PSIG
TMO Max. Operating Temperature	Saturated Steam Temp.
PMA Max. Allowable Pressure	1032 PSIG @ 100°F
TMA Max. Allowable Temperature	750°F @ 800 PSIG



Air Vents are used for Removing Air from Steam Systems

Typical Applications

The **AV2000** air vent is used on industrial steam applications up to 650 PSIG for the removal of air and non-condensable gases from process equipment, vessels and piping. The air vent should be located at a high point in the system or vessel and can be installed in any orientation.

How It Works

The thermostatic air vent contains a welded stainless steel thermal element that expands when heated and contracts when cooled. When air and non-condensable gases are present, the valve is in the open discharge position. When steam reaches the air vent, the element expands and closes the valve off tightly.

Features

- Welded stainless steel thermal element
- Hardened stainless steel seat and valve plugs for extended service life
- Integral strainer to protect from contamination
- Steam pressures up to 650 PSIG
- Special Subcool Options Available

Sample Specification

Air vent shall have a thermal element with a seal-welded tamper-proof stainless steel construction. All internals shall be stainless steel, featuring an integral strainer and hardened seat and disc.

Installation

The air vent should be located at a high point in the system or vessel and can be installed in any orientation. An isolation valve should be installed to facilitate removal and replacement without system shut-down. Unit is seal-welded and non-repairable.

MATERIALS

Housing	Stainless Steel, ASTM A351-CF3
Thermal Element	Stainless Steel
Valve & Seat	Hardened Stainless Steel, 40 Rc
Strainer Screen .033" perf.	Stainless Steel

Size/Connection NPT	Model Code	Orifice Size	PMO PSI	Weight lbs
1/2"	AV2001-12-N	3/16"	650	1.25
1/2"	AV2003-12-N	5/16"	650	1.25
3/4"	AV2001-13-N	3/16"	650	1.25
3/4"	AV2003-13-N	5/16"	650	1.25

DIMENSIONS – inches

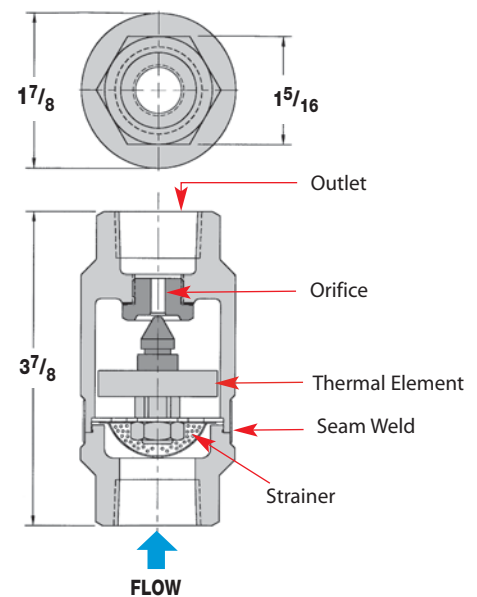

PIPELINE ACCESSORIES

CAPACITIES – Air (SCFM)

Model	Orifice Size	PMO (PSIG)	Inlet Pressure (PSIG)																	
			2	5	10	25	50	100	125	150	200	250	300	350	400	450	500	550	600	650
AV2001	3/16"	650	5.2	6.2	7.7	12.4	20.2	35.9	43.9	51.5	67.2	82.8	98.5	114	130	145	161	177	192	208
AV2003	5/16"	650	10.7	12.6	15.8	25.4	41.4	73.3	89.4	105	137	169	201	233	265	297	329	361	393	425

Y-Type Strainers • Cast Iron

Model	CIY
Sizes	1/2", 3/4", 1", 1 1/4", 1 1/2", 2", 2 1/2", 3", 4"
Connections	NPT, FLG
Body Material	Cast Iron



PRESSURE/TEMPERATURE RATINGS

NPT	250 PSIG @ 406°F - Steam
NPT	400 PSIG @ 150°F - WOG
125# FLG	125 PSIG @ 450°F - Steam
125# FLG	200 PSIG @ 150°F - WOG
250# FLG	250 PSIG @ 450°F - Steam
250# FLG	500 PSIG @ 150°F - WOG

Note: WOG = Water, Oil or Gas.

Typical Applications

The CIY Y-Strainer is used to strain dirt particles from fluid in pipelines and provide inexpensive protection for costly pumps, meters, valves, traps, turbines and compressors.

Features

- Machined seat assures perfect fit for screen
- Blowdown connection and easily removable stainless steel cylindrical screens for easy maintenance
- Durable cast iron body

Installation

The strainer should be installed in the flow direction as indicated on the body in either a vertical down or horizontal pipeline. The strainer must be accessible for periodic cleaning.

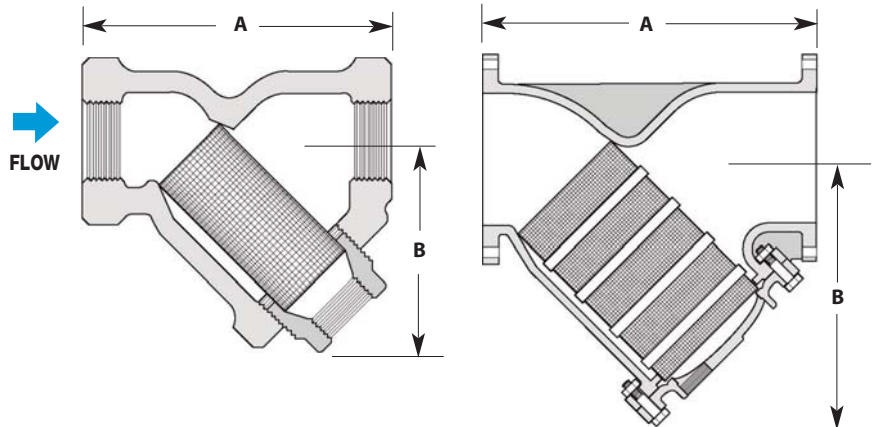

DIMENSIONS & WEIGHTS – inches

Size/ Connection	Model Code	A	B	Blowdown NPT	Weight (lbs)	Screen Mesh
1/2" NPT	CIY-12-N-020	3 ³ / ₁₆	2 ¹ / ₁₆	1/4	1.5	20
3/4" NPT	CIY-13-N-020	3 ³ / ₄	2 ⁷ / ₁₆	3/8	2.5	20
1" NPT	CIY-14-N-020	4	2 ⁷ / ₁₆	3/8	3.5	20
1 1/4" NPT	CIY-15-N-020	5	3 ³ / ₈	3/4	6	20
1 1/2" NPT	CIY-16-N-020	5 ³ / ₄	3 ⁷ / ₈	3/4	9	20
2" NPT	CIY-17-N-020	7	4 ³ / ₄	1	14	20
2" 125# FLG	CIY-17-F125-045	7 ⁷ / ₈	6	1/2	20	45
2" 250# FLG	CIY-17-F250-045	9 ⁵ / ₈	6 ¹ / ₂	1/2	26	45
2 1/2" NPT	CIY-18-N-045	9 ¹ / ₄	5 ⁷ / ₈	1 1/2	26	45
2 1/2" 125# FLG	CIY-18-F125-045	10	8	1	33	45
2 1/2" 250# FLG	CIY-18-F250-045	10 ⁵ / ₈	7	1	45	45
3" NPT	CIY-19-N-045	10	6	1 1/2	32	45
3" 125# FLG	CIY-19-F125-045	10 ¹ / ₄	8 ³ / ₄	1	37	45
3" 250# FLG	CIY-19-F250-045	12	8	1	60	45
4" 125# FLG	CIY-20-F125-045	12 ¹ / ₈	9 ¹ / ₂	1 1/2	70	45
4" 250# FLG	CIY-20-F250-045	14 ¹ / ₂	10 ³ / ₄	1 1/2	94	45

MATERIALS

Body	Cast Iron, A126 CLASS B
Plug	Cast Iron, A126 CLASS B
Cover	Cast Iron, A126 CLASS B
*Screen	Stainless Steel
*Gasket	Grafoil
*Gasket (Flg Cover)	Garlock 3000

Y-Type Strainers • Carbon Steel / Stainless Steel

Model	CSY, SSY
Sizes	1/2", 3/4", 1", 1 1/2", 2"
Connections	NPT, SW
Body Material	Carbon Steel (CSY) Stainless Steel (SSY)

PRESSURE/TEMPERATURE RATINGS

Carbon Steel	NPT	600 PSIG @ 489°F
Stainless Steel	NPT	600 PSIG @ 489°F

Typical Applications

The CSY/SSY Y-Strainers are used to strain dirt particles from fluid in pipelines and provide inexpensive protection for costly pumps, meters, valves, traps, turbines and compressors.

Features

- Machined seat assures perfect fit for screen
- Blowdown connection and easily removable stainless steel cylindrical screens for easy maintenance
- Choice of carbon steel or stainless steel bodies

Installation

The strainer should be installed in the flow direction as indicated on the body in either a vertical down or horizontal pipeline. The strainer must be accessible for periodic cleaning.

HOW TO ORDER

Specify connection size and connection configuration (NPT or SW) that will meet application requirements.

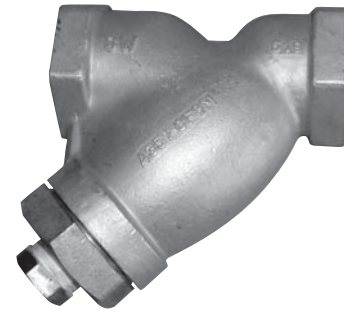

MATERIALS

	CSY Carbon Steel	SSY Stainless Steel
Body	Steel, A216 GR WCB	SS, A351 GR CF8M
Plug	Steel, A216 GR WCB	SS, A351 GR CF8M
Cover	Steel, A216 GR WCB	SS, A351 GR CF8M
Screen	Stainless	Stainless
Gasket	SS Spiral Wound	SS Spiral Wound

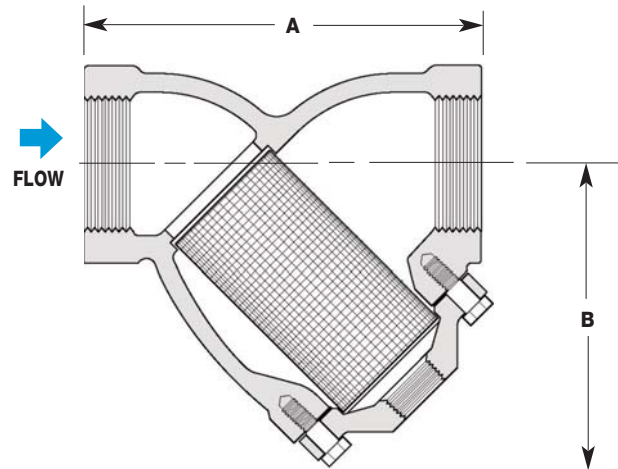

DIMENSIONS & WEIGHTS – inches

Size	Connection	Model Code	Model Code	Screen Mesh Size	A	B	Blowdown NPT	Weight lbs
		Carbon Steel	Stainless Steel					
1/2"	NPT	CSY-12-N-020	SSY-12-N-020	20	3	27/16	1/4	1.5
	SW	CSY-12-SW-020	SSY-12-SW-020					
3/4"	NPT	CSY-13-N-020	SSY-13-N-020	20	3 3/4	2 15/16	3/8	2.5
	SW	CSY-13-SW-020	SSY-13-SW-020					
1"	NPT	CSY-14-N-020	SSY-14-N-020	20	4 5/8	3 3/4	3/8	5
	SW	CSY-14-SW-020	SSY-14-SW-020					
1 1/2"	NPT	CSY-16-N-020	SSY-16-N-020	20	5 5/8	4 13/16	3/4	9
	SW	CSY-16-SW-020	SSY-16-SW-020					
2"	NPT	CSY-17-N-020	SSY-17-N-020	20	7	6 1/8	1	13
	SW	CSY-17-SW-020	SSY-17-SW-020					

For special mesh screens; Consult factory.
CS not recommended for prolonged use above 800°F.
SS not recommended for prolonged use above 1000°F.

Cast Iron, Bronze or Stainless Steel

Model	Suction Tee	
Sizes	1/2", 3/4", 1", 1 1/4", 1 1/2", 2", 2 1/2", 3"	
Connections	NPT	
Body Material	Cast Iron	125# & 250#
	Bronze	250#
	Stainless Steel	300#

PRESSURE/TEMPERATURE RATINGS

Cast Iron	NPT	250 PSIG @ 406°F
Bronze	NPT	300 PSIG @ 422°F
Stainless Steel	NPT	450 PSIG @ 400°F



Typical Applications

The Watson McDaniel Cast Iron, Bronze or Stainless Steel **Suction Tee** is a specialized type of pipe fitting used for blending, agitation, recirculation, mixing, aeration and heating.

How It Works

Heating by Direct Steam Injection: When using a Suction Tee for heating by direct steam injection, the Suction Tee must be completely submerged in the liquid being heated. When steam enters the primary inlet side of the Suction Tee, a low pressure condition is created inside the Suction Tee body. This causes the liquid inside the tank to circulate through the suction tee and intermix with the steam, causing the liquid to be heated.

Mixing: When liquid is pumped through the primary inlet of a Suction Tee, a low pressure region is created inside the Suction Tee body. When a Suction Tee is submerged, the liquid inside the tank will circulate through the secondary inlet of the Suction Tee causing a mixing action to occur. An alternate method when mixing two different liquids is to pump one liquid through the primary inlet and the other liquid through the secondary inlet of the Suction Tee.

Aeration: A tank or reservoir of liquid can be aerated by connecting the secondary inlet of the Suction Tee to an air or gas line under pressure while pumping liquid through the primary inlet.

Features

- Available in cast iron, bronze or stainless steel
- No moving parts
- Quiet operation
- Replaces mixing pumps, propellers and other mechanical devices

Size/Connection NPT	Model Code	Material	PMO PSI	Weight (lbs)
1/2"	SUCT-12-N-CI-125	Cast Iron	125	1.25
	SUCT-12-N-B-250	Bronze	250	1.50
3/4"	SUCT-13-N-CI-125	Cast Iron	125	2.50
	SUCT-13-N-B-250	Bronze	250	3.50
1"	SUCT-14-N-CI-125	Cast Iron	125	4.50
	SUCT-14-N-CI-250	Cast Iron	250	6.00
	SUCT-14-N-B-250	Bronze	250	4.50
1 1/4"	SUCT-14-N-SS-300	316 SS	300	4.50
	SUCT-15-N-CI-125	Cast Iron	125	5.00
	SUCT-15-N-CI-250	Cast Iron	250	8.50
1 1/2"	SUCT-15-N-B-250	Bronze	250	5.50
	SUCT-16-N-CI-125	Cast Iron	125	6.00
	SUCT-16-N-CI-250	Cast Iron	250	9.50
2"	SUCT-16-N-B-250	Bronze	250	6.25
	SUCT-16-N-SS-300	316 SS	300	6.25
	SUCT-17-N-CI-125	Cast Iron	125	7.50
2 1/2"	SUCT-17-N-CI-250	Cast Iron	250	17.0
	SUCT-17-N-B-250	Bronze	250	9.75
	SUCT-17-N-SS-300	316 SS	300	9.25
3"	SUCT-18-N-CI-125	Cast Iron	125	11.0
	SUCT-19-N-CI-125	Cast Iron	125	21.5
	SUCT-19-N-CI-250	Cast Iron	250	38.0

Cast Iron, Bronze or Stainless Steel

DIMENSIONS & WEIGHTS – inches						
Pipe Size	A	B	C	D	E	Weight (lbs)
125# Cast Iron Body & Bronze 250#						
1/2"	3 ³ / ₄	1 ¹ / ₂	2 ¹ / ₄	1 ³ / ₄	1/4	1.5
3/4"	5	1 ⁷ / ₈	3 ¹ / ₈	3 ¹ / ₈	3/8	3.25
1"	5 ⁵ / ₈	2 ³ / ₁₆	3 ⁷ / ₁₆	2 ¹ / ₂	5/8	4
1 ¹ / ₄ "	5 ³ / ₄	2 ¹ / ₄	3 ¹ / ₂	2 ¹ / ₂	11/16	4.75
1 ¹ / ₂ "	6 ¹ / ₁₆	2 ⁷ / ₁₆	3 ⁵ / ₈	2 ⁷ / ₈	7/8	5.50
2"	7	2 ⁷ / ₈	4 ¹ / ₈	3	15/16	7
2 ¹ / ₂ "	8 ³ / ₈	3 ¹ / ₂	4 ⁷ / ₈	3 ⁵ / ₁₆	1	11.75
3"	9 ¹ / ₂	4 ¹ / ₈	5 ³ / ₈	3 ⁷ / ₈	1 ⁵ / ₁₆	20.50
250# Cast Iron Body & Stainless Steel 300#						
1"	6 ¹ / ₁₆	2 ⁵ / ₁₆	3 ³ / ₄	2 ¹¹ / ₁₆	11/16	6.75
1 ¹ / ₄ "	6 ³ / ₁₆	2 ³ / ₈	3 ¹³ / ₁₆	2 ¹³ / ₁₆	11/16	8
1 ¹ / ₂ "	6 ¹ / ₂	2 ¹³ / ₁₆	3 ¹¹ / ₁₆	2 ⁷ / ₈	7/8	10.50
2"	7 ³ / ₈	3 ¹ / ₁₆	4 ⁵ / ₁₆	3 ¹ / ₄	15/16	16.50

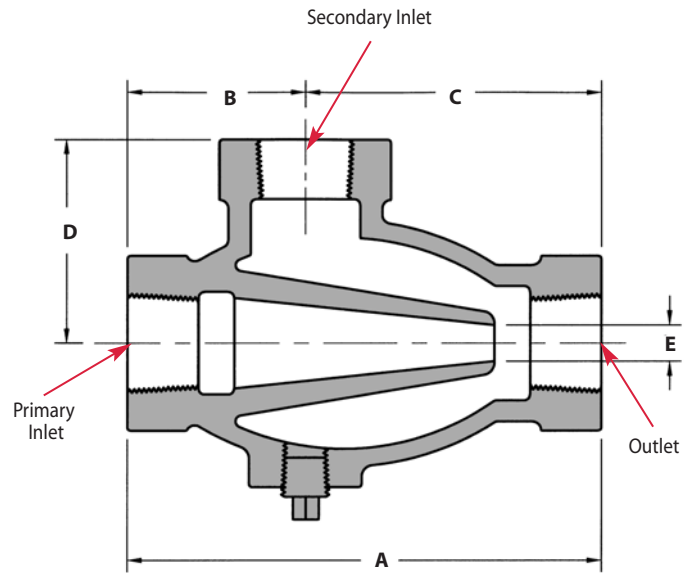

MATERIALS

Cast Iron	
Body	Cast Iron, A126 CLASS 30
Plug	Cast Iron, A126 CLASS 30
Bronze	
Body	Bronze, ASTM B-62
Plug	Brass
Stainless Steel	
Body	Stainless Steel, A351 GR CF8M
Plug	Stainless Steel, A351 GR 316

CAPACITIES – Steam (lbs/hr)

Size	Supply Pressure (PSIG)																	
	5	10	15	20	25	30	35	40	45	50	55	60	65	75	85	100	125	150
1/2"	66	96	114	135	156	165	174	207	240	258	276	294	312	354	396	456	552	630
3/4"	108	138	168	198	228	255	282	309	336	363	390	402	414	504	564	648	792	936
1"	312	390	468	549	630	711	792	882	972	1026	1080	1170	1260	1428	1584	1800	2232	2556
1 ¹ / ₄ "	444	558	672	783	894	1005	1116	1230	1344	1461	1578	1689	1800	2010	2232	2592	3168	3708
1 ¹ / ₂ "	612	756	900	1026	1152	1332	1512	1674	1836	1980	2124	2286	2448	2772	3060	3528	4320	5040
2"	798	1008	1206	1410	1614	1815	2016	2214	2412	2610	2808	3024	3240	3636	3996	4680	5652	6696
2 ¹ / ₂ "	912	1152	1368	1584	1800	2052	2304	2538	2772	2997	3222	3447	3672	4140	4608	5292	6480	7560
3"	1332	1656	1980	2304	2628	2970	3312	3636	3960	4302	4644	4986	5328	5976	6600	7620	9300	10800

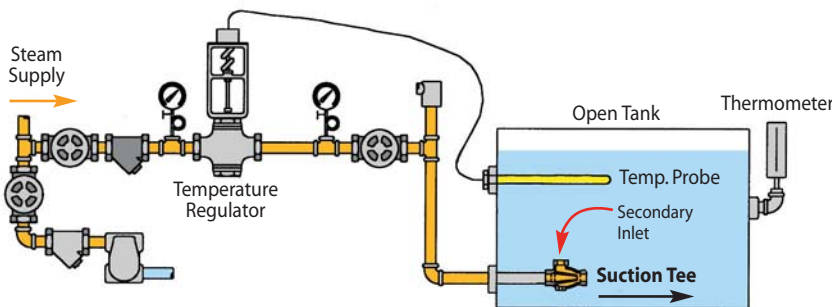

Controlling temperature of large open tank by steam injection

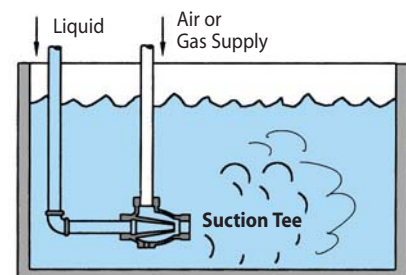

Aeration or Agitation

Syphons, Educators, Exhausters & Injectors

Model	EJECT EJECT-ELL EJECT-LM
Sizes	1/2" – 2"
Connections	NPT
Body Material	Bronze (1/2" - 1 1/2") Cast Iron (2")
PMO Max. Operating Pressure	100 PSIG
TMO Max. Operating Temperature	130°F
PMA Max. Allowable Pressure	250 PSIG up to 450°F
TMA Max. Allowable Temperature	450°F @ 250 PSIG

Note: Minimum Operating Pressure for EJECT-ELL & EJECT-LM is 20 PSIG.

Typical Applications

Watson McDaniel Ejectors perform a variety of functions depending upon the application and motive fluid (steam or water) used. See performance charts on the following pages. Applications include: exhausting, agitating, aerating, circulating, pumping and mixing.

How It Works

Using water, steam or air pressure as the motive force, ejectors operate on the principle that a high velocity flow through a nozzle will create a pressure drop in the area around the nozzle discharge. The resulting vacuum will induce flow into the secondary inlet of the ejector.

Features

- No moving parts
- Can be used with water or steam pressure
- Submersible
- Available in cast iron or bronze

Sample Specification

Ejectors shall be constructed from bronze or cast iron. Units shall be capable of using steam, water or air as a motive force.

Installation

See installation examples on following page.

MATERIALS

Body (1/2" - 1 1/2")	Bronze
Body (2")	Cast Iron
Nozzles (all sizes)	Bronze

Note: EJECT-ELL & EJECT-LM for liquid motive service only.



Model EJECT can be used with Steam or Water as the Motive Inlet

EJECT

Size/Connection NPT	Model Code	Motive Fluid Used	Suction Fluid	Weight lbs
1/2"	EJECT-12-N-S	Steam	Water	0.75
	EJECT-12-N-W	Water	Water	0.75
3/4"	EJECT-13-N-S	Steam	Water	0.75
	EJECT-13-N-W	Water	Water	0.75
1"	EJECT-14-N-S	Steam	Water	1.50
	EJECT-14-N-W	Water	Water	1.50
1 1/4"	EJECT-15-N-S	Steam	Water	3.75
	EJECT-15-N-W	Water	Water	3.75
1 1/2"	EJECT-16-N-S	Steam	Water	4.75
	EJECT-16-N-W	Water	Water	4.75
2"	EJECT-17-N-S	Steam	Water	7.50
	EJECT-17-N-W	Water	Water	7.50



EJECT-ELL

Motive Fluid is LIQUID

Size/Connection NPT	Model Code	Motive Fluid Used	Suction Fluid	Weight lbs
3/4"	EJECT-ELL-13-N	Water	Gases	4.00
1"	EJECT-ELL-14-N	Water	Gases	7.00
1 1/4"	EJECT-ELL-15-N	Water	Gases	8.00



EJECT-LM

Motive Fluid is LIQUID

Size/Connection NPT	Model Code	Motive Fluid Used	Suction Fluid	Weight lbs
3/4"	EJECT-LM-13-N	Water	Water	1.00
1"	EJECT-LM-14-N	Water	Water	2.25
1 1/4"	EJECT-LM-15-N	Water	Water	3.50

Syphons, Educutors, Exhausters & Injectors

EJECT

DIMENSIONS — inches							
Size	Connection Sizes *			Dimensions			
	S. Inlet	Discharge	P. Inlet	A	B	C	D
Bronze Body & Nozzles							
1/2"	1/2	1/2	1/4	3 1/4	17/16	1 13/16	1 1/8
3/4"	3/4	3/4	3/8	4	1 1/2	2 1/2	1 3/8
1"	1	1	1/2	5 1/8	2 1/4	2 7/8	1 5/8
1 1/4"	1 1/4	1 1/4	3/4	5 7/8	2 7/16	3 7/16	1 13/16
1 1/2"	1 1/2	1 1/2	3/4	6 1/4	2 11/16	3 9/16	1 15/16
Cast Iron Body with Bronze Nozzles							
2"	2	2	1	7 1/4	3 1/8	4 1/8	2 3/8

* Connections are female NPT.

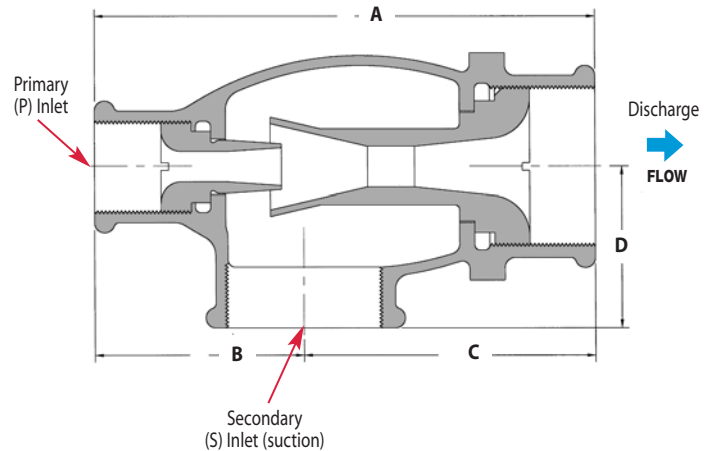

EJECT-ELL / EJECT-LM

Bronze Body & Nozzles

DIMENSIONS — inches						
Size	Connection Sizes **			Dimensions		
	S. Inlet	Discharge	P. Inlet	A	B	D
3/4"	3/4	3/4	1/2	5 13/16	2	1 3/8
1"	1	1	3/4	7 1/8	2 5/16	1 3/4
1 1/4"	1 1/4	1 1/4	1	9	2 7/16	2 1/8

** Connections are male NPT.

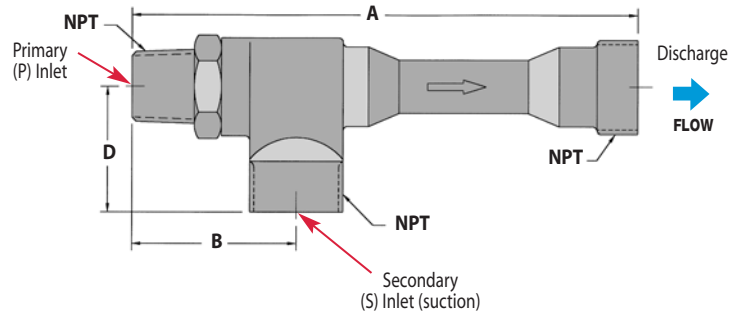

Ejectors shown Pumping Liquid

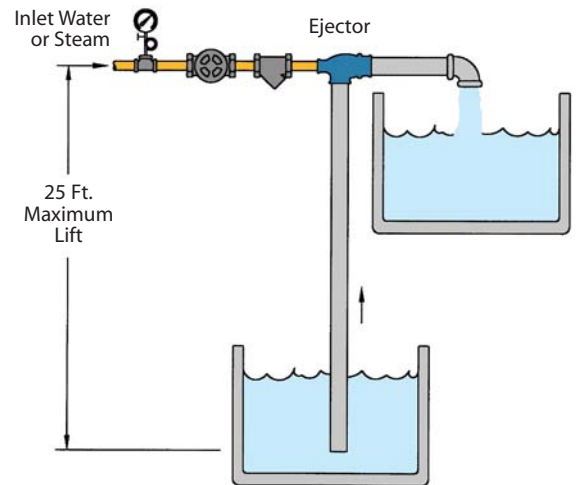
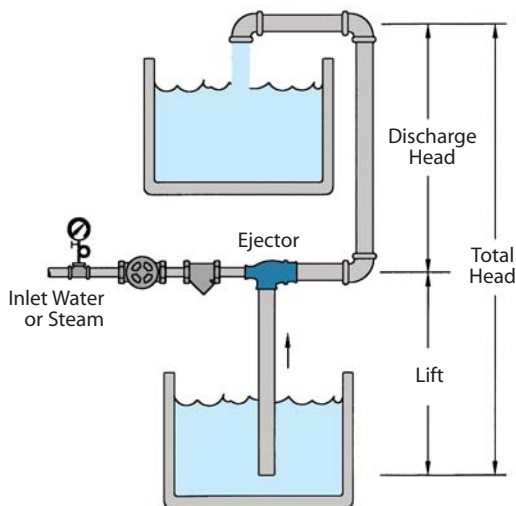

It is always desirable to keep the Ejector as close to the actual liquid being pumped as possible. The maximum height the liquid can be pumped depends upon the pressure of the "motive" liquid or steam available. Please refer to the capacity graphs for maximum flow rates and maximum achievable heads.

The maximum height that water or any liquid with a specific gravity of 1 can be lifted is 25 feet. Increases in the temperature of the liquid being lifted will cause this maximum height to decrease. Pumping liquids in excess of 130°F is not recommended. Please consult factory with any specific application.

Ejector Sizing • EJECT Model

Example 1

A #14 1" Ejector using 60 lbs. of water pressure as a motive force will pump water to a maximum height of 40 ft. When pumping water to a height of 20 ft. using 60 lbs. of water pressure, the amount of water being pumped is 700 gal/hr.

Example 2

A #14 1" Ejector using 60 lbs. of steam pressure as a motive force will pump water to a maximum height of 60 ft. When pumping water to a height of 53 ft. using 60 lbs. of steam pressure, the amount of water being pumped is 650 gal/hr.

for Model EJECT Only (Water)

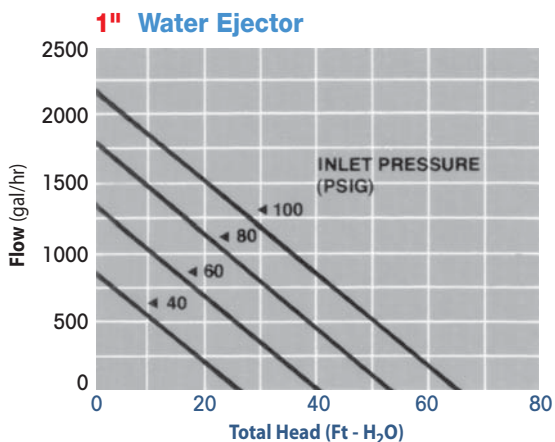
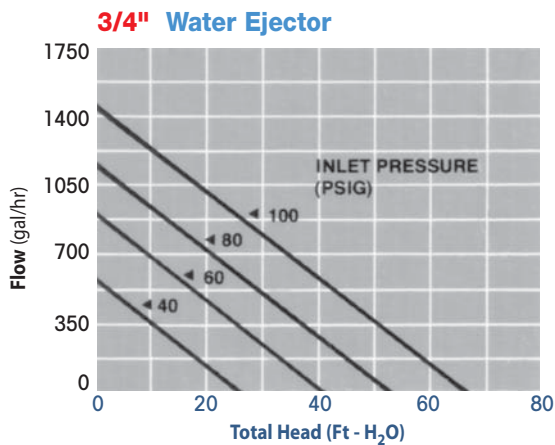
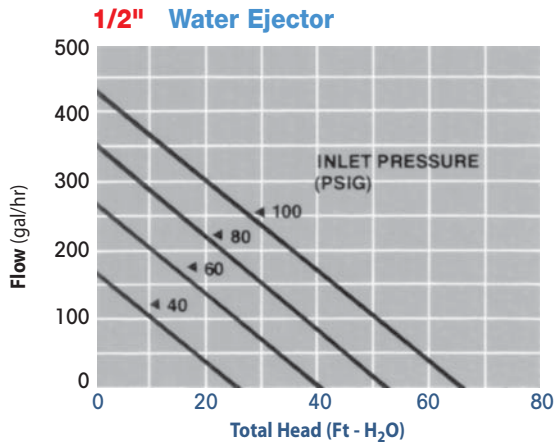

for Model EJECT Only (Steam)

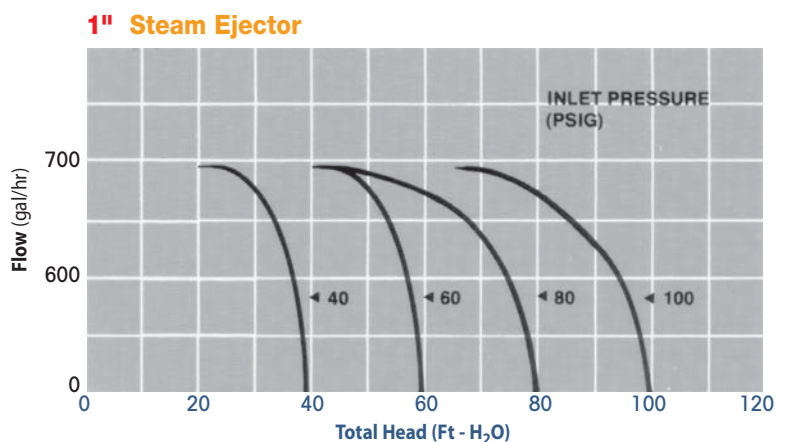
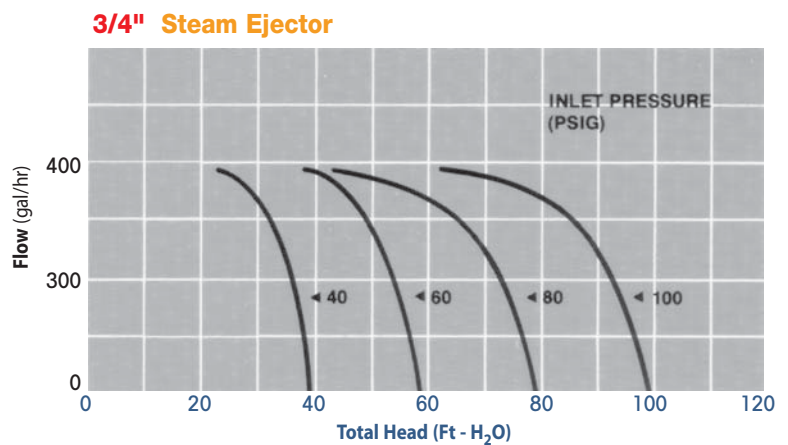
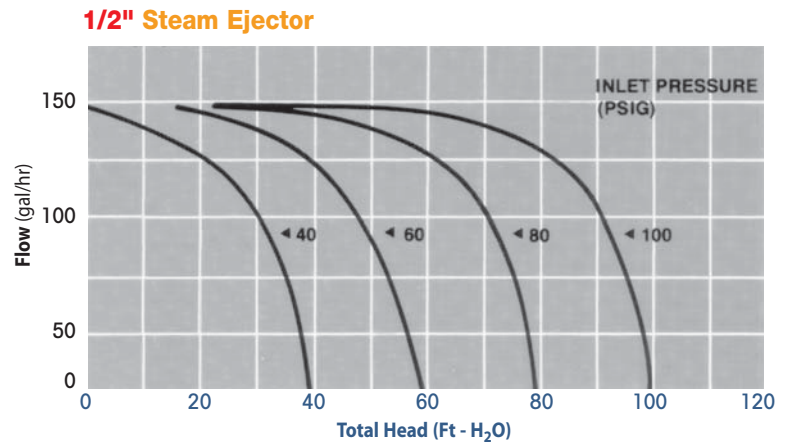

Ejector Sizing • EJECT Model

for Model EJECT Only (Water)

1 1/4" Water Ejector

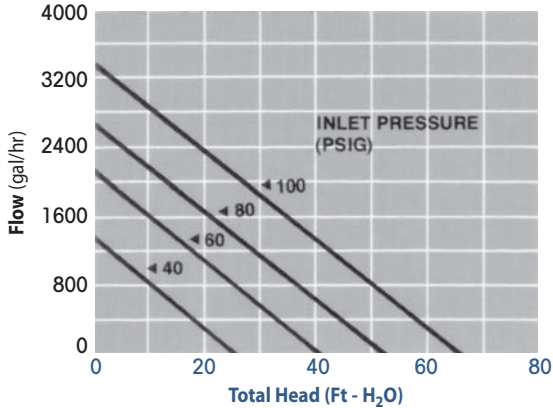

1 1/2" Water Ejector

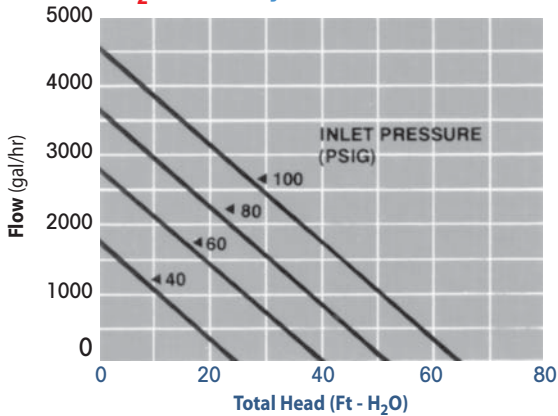

2" Water Ejector

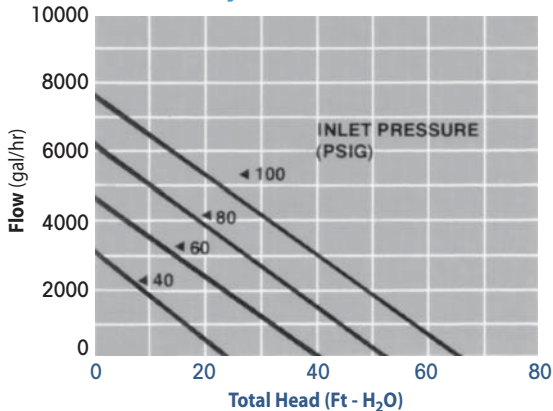

for Model EJECT Only (Steam)

1 1/4" Steam Ejector

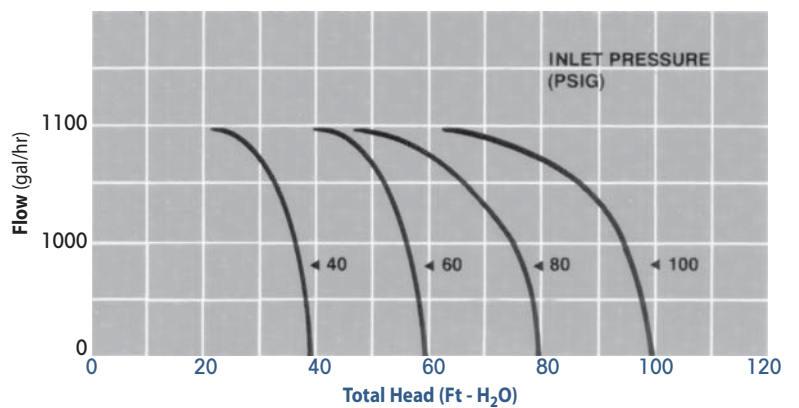

1 1/2" Steam Ejector

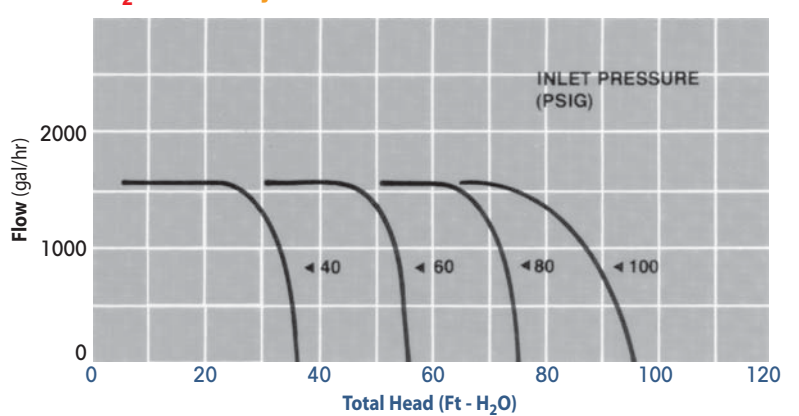

2" Steam Ejector

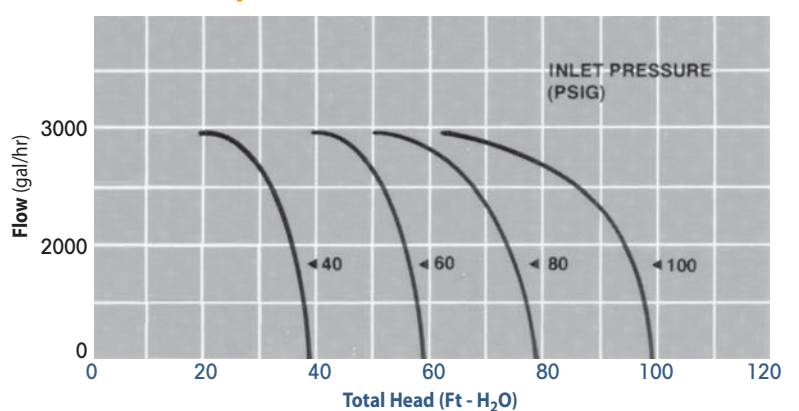

Model Code	AV813-13-N *
Sizes	3/4"
Connections	NPT
Body Material	Cast Iron
PMO Max. Operating Pressure	150 PSIG
TMO Max. Operating Temperature	300°F
PMA Max. Allowable Pressure	150 PSIG up to 350°F
TMA Max. Allowable Temperature	353°F @ 150 PSIG

* With Viton seat, use Model Code **AV813V-13-N**



Air Eliminators are used for Removing Air from Liquid Systems

Typical Applications

The **AV813** Air Eliminator is used for the removal of air and other gases from vessels or piping systems without allowing the contained liquid to escape.

How It Works

The valve and seat assembly inside the air eliminator is connected to a stainless steel float. When there is no liquid in the body of the air eliminator, the float will be in the down position, allowing air or other gases in the vessel or piping system to escape. When liquid enters the body, it will lift the float and the valve will be closed off before any liquid can escape.

Features

- Rugged cast iron housing
- Simple design for easy maintenance
- Stainless steel internals
- Optional Viton Valve Head for high temperatures and tight shut-off

Sample Specification

Air Eliminator shall be of cast iron construction with stainless steel internals and soft EPDM seat for tight shut-off. Optional Viton seat is available for elevated temperatures and tight shut-off.

Installation & Maintenance

The AV813 should be located at a high point in the system or vessel. The unit must be installed level and upright with flow upward for the float mechanism to operate properly. Isolation valves should be installed for ease of maintenance.

MATERIALS

Cover	Cast Iron, ASTM A-126, Class B
Body	Cast Iron, ASTM A-126, Class B
Gasket	Grafoil
Seat Yoke	Stainless Steel, Type 304
Valve Seat	Stainless Steel, Type 304
Pivot Pin	Stainless Steel, Type 304
Valve Head	EPDM (Viton optional)
Lever	Stainless Steel, Type 304
Float	Stainless Steel, Type 304
Washer	Stainless Steel, Type 304
Screw & Washer	Stainless Steel, Type 304

DIMENSIONS – inches

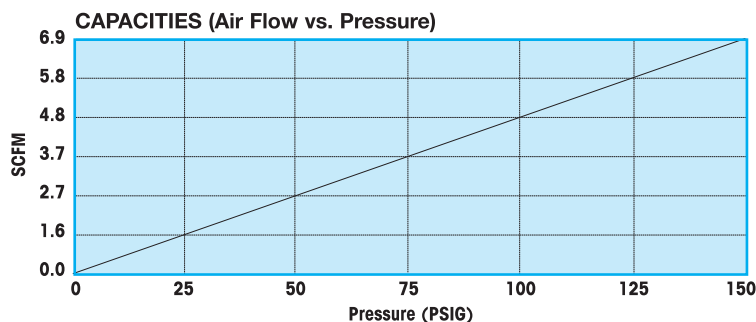
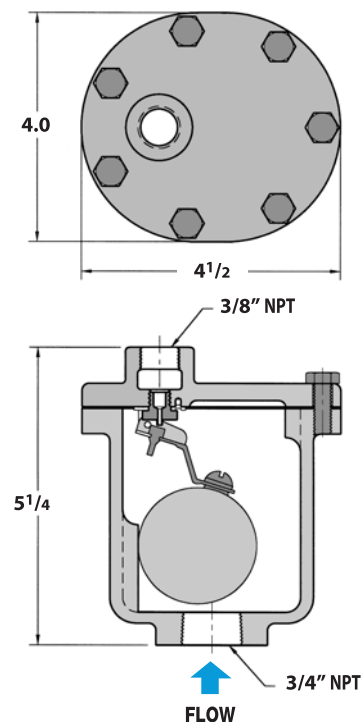

Repairable & Non-Repairable

Model	AE1800, AE1800R
Sizes	1/2", 3/4"
Connections	NPT
Body Material	Stainless Steel
PMO Max. Operating Pressure	400 PSIG
TMO Max. Operating Temperature	500°F
PMA Max. Allowable Pressure	400 PSIG up to 500°F
TMA Max. Allowable Temperature	500°F @ 400 PSIG



AE1800
(Non-Repairable)



AE1800R
(Repairable)

Air Eliminators are used for Removing Air from Liquid Systems

Typical Applications

The AE1800 Air Eliminator is used for the removal of air and other gases from vessels or piping systems without allowing the contained liquid to escape.

How It Works

The valve and seat assembly inside the air eliminator is connected to a stainless steel float. When there is no liquid in the body of the air eliminator, the float will be in the down position, allowing air or other gases in the vessel or piping system to escape. When liquid enters the body, it will lift the float and the valve will be closed off before any liquid can escape.

Features

- All stainless steel body and internals
- Hardened SS seat (55 Rc) for longer service life
- Repairable units available (AE1800R Series)

Installation & Maintenance

The AE1800 should be located at a high point in the system or vessel. The unit must be installed level and upright with flow upward for the float mechanism to operate properly. Isolation valves should be installed for ease of maintenance.

DIMENSIONS – inches / pounds						
Model Code & Orifice Size			Size NPT (Inlet x Outlet)	Height A	Weight (lbs)	
.078"	.101"	.125"				
AE1811-N	AE1821-N	AE1831-N	3/4" x 1/2"	7.5	4	
AE1811R-N	AE1821R-N	AE1831R-N		7.9	5	
AE1812-N	AE1822-N	AE1832-N	3/4" x 3/4"	7.5	4	
AE1812R-N	AE1822R-N	AE1832R-N		7.9	5	
AE1813-N	AE1823-N	AE1833-N	1/2" x 1/2"	7.5	4	
AE1813R-N	AE1823R-N	AE1833R-N		7.9	5	

MATERIALS

Body & Shell	Stainless Steel, AISI 304
Float Assembly	Stainless Steel, AISI 304
Valve & Lever Assembly	Hardened Stainless Steel, 55 Rc
Seat	Stainless Steel, AISI 420
Washer, Seat	302 SS
*Gasket	Grafoil
*Bolt, Hex, HD	Stainless Steel, AISI 316
*Nut	Stainless Steel, 18-8

* AE1800R Repairable models only.

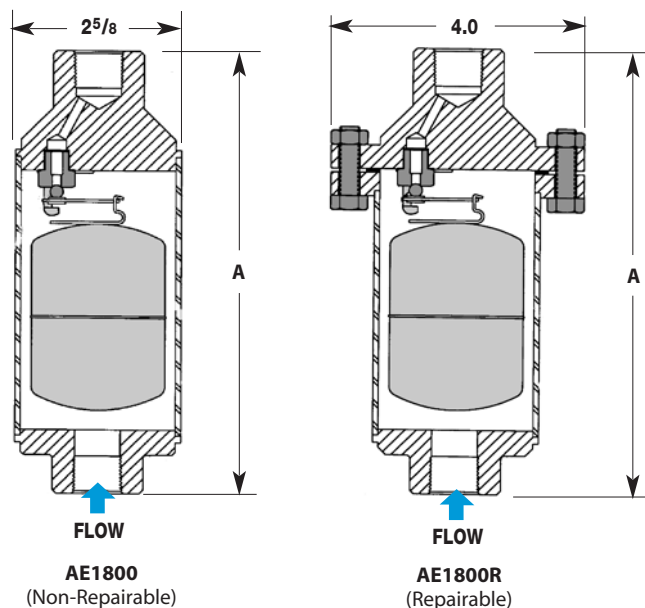

PIPELINE ACCESSORIES

CAPACITIES – Air (SCFM)																									
Series	Orifice Size	PMO* (PSIG)	Inlet Pressure (PSIG)																						
			5	7	9	12	15	20	25	30	40	50	60	70	80	90	100	110	120	125	150	180	265	300	400
AE1810	.078"	400	1.0	1.1	1.3	1.5	1.7	1.9	2.2	2.5	3.1	3.4	3.7	4.2	5.4	6.0	6.8	7.2	7.5	7.9	9.4	11.2	16.3	18.4	24.4
AE1820	.101"	265	1.7	1.9	2.1	2.4	2.6	3.1	3.5	4.0	4.8	5.3	5.7	6.6	8.4	9.3	10.2	11.1	12	12.4	14.5	17.3	24.8	-	-
AE1830	.125"	180	2.5	3.0	3.4	3.9	4.3	5.1	5.8	6.5	8.0	8.7	9.5	10.9	13.9	15.4	16.9	18.4	19.9	20.5	24.4	29.6	-	-	-

Note: Specify Model Number when ordering. Example: AE1812R-N (.078" Orifice, 3/4" x 3/4" NPT, 400 PSIG max, Repairable unit)

* PMO based on liquids with specific gravity of 1. Consult factory for PMO for liquids of other specific gravity values.

Cast Iron or Carbon Steel

Model	WDS	
Body Material	Cast Iron	Carbon Steel
Sizes	3/4" thru 4"	1" thru 12"
Connections	NPT, 125# Flanged	NPT, SW, 150# & 300# Flanged
PMO Max. Operating Pressure	250 PSIG	300 PSIG (NPT & SW)
Pressure/ Temperature Rating	NPT: 250 PSIG @ 450°F 125# FLG: 150 PSIG @ 450°F	NPT, SW: 1000 PSIG @ 650°F 150# FLG: 150 PSIG @ 450°F 300# FLG: 500 PSIG @ 650°F

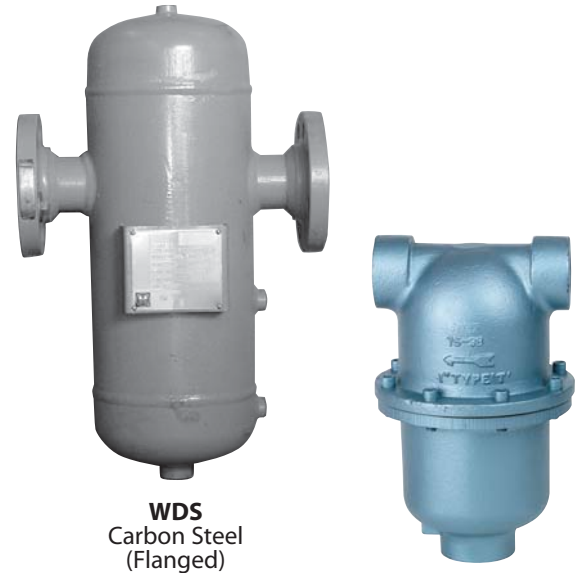

WDS
Carbon Steel
(Flanged)

WDS
Cast Iron
(NPT)

Typical Applications

The WDS Series Separators are used for the removal of entrained liquid or solids from steam or air. Effective in applications where the system has an entrained liquid flow rate of up to 40% by weight of the unit's flow capacity.

How It Works

Wet steam enters the inlet of the separator where it is deflected in a centrifugal downward motion. The entrained moisture is separated out by reduction in velocity. Separated liquid then falls below the Vortex Containment Plate where it cannot be re-entrained. Dry steam or air then flows upward and exits through the outlet of the separator.

Features

- Removes 99% of all particles ≥ 10 microns in size
- Minimum pressure drop
- Gauge ports on 3" & 4" cast iron units
- Standard gauge ports on 2 1/2"-12" carbon steel units
- ASME Code constructed

Sample Specification

Steam Moisture Separator shall be "T" style for horizontal piping installations. Separator to be code constructed in cast iron or carbon steel and available in FNPT and flanged connections.

Installation

The WDS Air/Steam Moisture Separator must be installed in a horizontal run of pipe. Exercise standard piping and structural practices when installing this unit. Proper drainage of the separator utilizing a float & thermostatic steam trap or liquid drainer (for air applications) is essential for proper operation.

MATERIALS

WDS Cast Iron Model	Cast Iron
WDS Carbon Steel Model	Fabricated Carbon Steel

CAPACITIES — Steam (lbs/hr)

Size	Operating Pressure (PSIG)											
	5	10	25	50	100	150	200	250	300	400*	450*	500*
3/4", 1"	192	219	289	384	536	661	772	872	964	1132	1210	1284
1 1/4"	305	348	459	609	851	1050	1225	1384	1531	1797	1921	2038
1 1/2"	434	495	653	868	1211	1495	1744	1970	2179	2559	2734	2902
2"	769	877	1156	1536	2143	2646	3087	3487	3857	4529	4839	5136
2 1/2"	1220	1391	1834	2437	3401	4199	4900	5535	6121	7188	7680	8151
3"	1912	2181	2876	3821	5333	6583	7682	8677	9597	11269	12041	12779
4"	3183	3632	4787	6362	8878	10959	12788	14446	15977	18760	20046	21274
5"	4823	5501	7252	9637	13449	16603	19373	21884	24203	28420	30367	32229
6"	7465	8516	11226	14917	20818	25699	29988	33874	37464	43992	47006	49887
8"	12444	14196	18713	24867	34704	42840	49989	56468	62452	73334	78359	83161
10"	19376	22104	29137	38720	54036	66705	77836	87924	97241	114186	122009	129487
12"	28560	32580	42947	57071	79648	98320	114728	129597	143331	168306	179836	190859

* Not to be used for steam service at these pressures. For air service only.

Cast Iron or Carbon Steel

WDS (Cast Iron)

WDS CAST IRON NPT DIMENSIONS – inches

Size (NPT)	A	B	C	Vent NPT	Drain NPT	Gauge Centers G	Weight (lbs)
3/4"	5 1/2	10 1/8	5 3/4	1/4	3/4	N/A	23
1"	6	10 1/8	6 3/4	1/4	1	N/A	26
1 1/4"	6	10 3/8	7	1/4	1	N/A	30
1 1/2"	7 1/4	13 1/8	8 1/8	1/4	1	N/A	45
2"	8 1/8	15 5/8	8 1/2	1/4	1	N/A	50
2 1/2"	12	18 1/4	11 3/8	1/4	1 1/4	N/A	95
3"	11	18 1/4	11 3/8	1/4	1 1/4	3 1/2	90

WDS CAST IRON FLANGED DIMENSIONS – inches

Size (Flanged)	A	B	C	Vent NPT	Drain NPT	Gauge Centers G	Weight (lbs)
2"	10 1/2	13 3/4	8 1/2	1/4	1	N/A	50
3"	14	16	11 3/8	1/4	1 1/4	4 3/4	95
4"	15 7/8	19 3/8	14	1/4	1 1/4	5 3/4	195

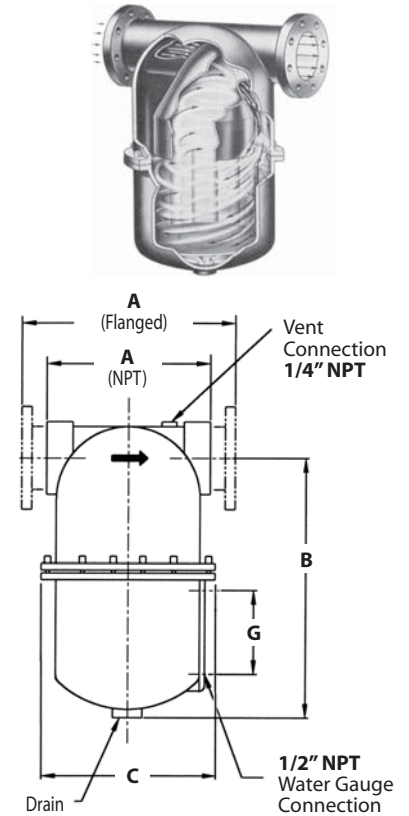

WDS (Carbon Steel)

WDS CARBON STEEL DIMENSIONS – inches

Size	NPT & SW		150# & 300# FLG			Gauge Centers G	NPT Drain		Weight (lbs)		
	A	A	B	C	D		Std.	Opt.	NPT & SW	150# FLG	300# FLG
1"	6 3/8	10 1/2	10 1/2	12	5 9/16	Opt.	1	1 1/2	29	33	35
1 1/4"	6 3/8	10 1/2	10 1/2	12	5 9/16	Opt.	1	1 1/2	30	35	37
1 1/2"	7 5/8	11 1/2	12 1/2	14	6 5/8	Opt.	1	2	55	50	56
2"	7 7/8	11 1/2	12 1/2	14	6 5/8	Opt.	1	2	57	55	59
2 1/2"	-	16	15	22	8 5/8	5 3/4	1	2	-	100	110
3"	-	18	18	26	10 3/4	5 3/4	1 1/2	2 1/2	-	140	150
4"	-	20	22	31	12 3/4	5 3/4	1 1/2	2 1/2	-	195	220
5"	-	22	26	36	14	7 7/8	1 1/2	2 1/2	-	230	290
*6"	-	*24	30	41	16	7 7/8	1 1/2	2 1/2	-	350	380
*8"	-	*28	37	50	18	7 7/8	2	3	-	475	610
*10"	-	*34	55	70	24	7 7/8	2	3	-	780	1180
*12"	-	*38	58	75	28	7 7/8	2 1/2	4	-	940	1510

Note: 1" - 2" units are Cast Steel; 2 1/2" and up are Fabricated Steel.

* Contact Factory for certified drawings on 6" through 12" models.

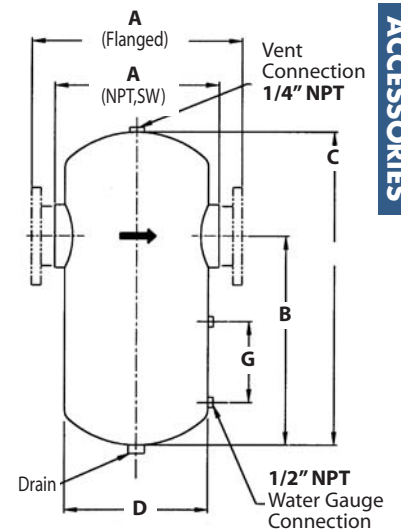
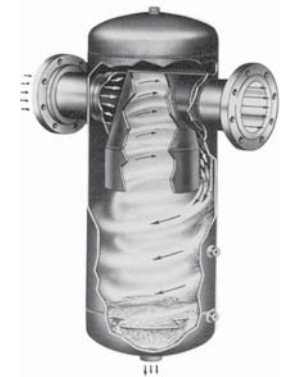

Cast Iron

Model	WCIS1	WCIS3
Sizes	3/4" – 2"	2 1/2" – 4"
Connections	NPT	ANSI 150#/300#
Body Material	Cast Iron	Cast Iron
PMO Max. Operating Pressure	360 PSIG	360 PSIG
TMO Max. Operating Temperature	662°F	662°F
PMA Max. Allowable Pressure	232 PSIG @ 248°F 160 PSIG @ 572°F	232 PSIG @ 248°F 188 PSIG @ 428°F
TMA Max. Allowable Temperature	572°F @ 160 PSIG	428°F @ 188 PSIG



WCIS1
Cast Iron



WCIS3
Cast Iron

Typical Applications

- On steam mains, as a drip station ahead of steam pressure reducing or temperature control valves
- On the steam inlet to laundry presses and other process equipment which require dry saturated steam
- On the compressed air supply to sensitive instruments and before filters

How It Works

When a vapor entrained with moisture enters the steam separator, a series of baffles change its flow direction several times. During the process, the baffles in the housing collect impinged water droplets that are carried in the vapor. Gravity causes the accumulated water droplets and other foreign particles to fall to the drain and exit through an external trap. This allows clean, dry vapor to exit at the outlet of the separator.

Features

- Removes 99% of all particles ≥ 10 microns in size
- Optimal gravity discharge
- Long-lasting cast iron construction

Sample Specification

Moisture Separator shall be of the high efficiency impingement type having a pressure drop that does not exceed an equivalent length of pipe. Body shall be iron with threaded or flanged connections. A threaded bottom drain shall be provided for the installation of a trap to discharge any accumulated liquid.

Installation

Install in a horizontal pipeline with the drain directly below the line. Recommended trap is a continuous draining float operated type.

Maintenance

The trap at the separator drain should be serviced periodically according to the manufacturer's instructions. The separator itself requires no maintenance.

MATERIALS

WCIS1 Body & Cover	Cast Iron ASTM A 126 GR CLB
WCIS3 Body	
WCIS1 Gasket	Semi-rigid Graphite Laminate
WCIS3 Gasket	Reinforced Exfoliated Graphite
Bolts	Steel UNF, BS 1766 Gr 5
Bushing	Malleable Iron
Plug	Malleable Iron

Air Capacities in SCFM (standard cubic feet per minute)

Size	Operating Pressure (PSIG)						
	20	40	60	80	100	145	200
3/4"	31	51	67	87	102	148	194
1"	51	82	108	138	169	245	322
1 1/2"	123	190	262	334	406	587	
2"	206	437	437	556	674	968	
2 1/2"	288	623	623	793	957	1380	
3"	370	803	803	1019	1236	1776	
4"	643	1385	1385	1756	2132	3059	

Saturated Steam Capacities in lbs/hr

Size	Operating Pressure (PSIG)						
	5	10	25	50	100	145	200
3/4"	68	82	128	203	349	496	635
1"	110	133	208	330	567	804	1030
1 1/2"	260	317	494	783	1347	1845	
2"	429	523	814	1292	3220	3041	
2 1/2"	612	746	1162	1844	3168	4340	
3"	946	1153	1795	2848	4893	6702	
4"	1630	1985	3092	4906	8427	11542	

Cast Iron

WCIS1 (Cast Iron)

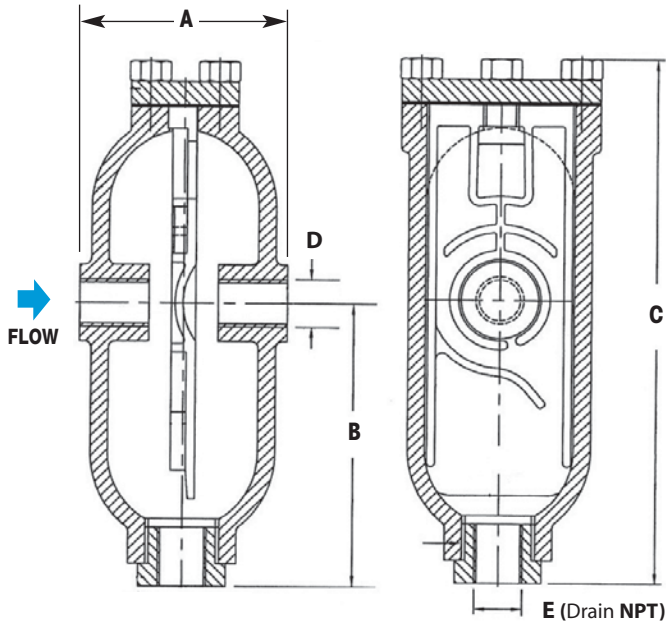

WCIS1 DIMENSIONS (nominal) - inches/mm						
Size	A	B	C	D	E	Weight
3/4"	4.75	6.69	14	3/4"	3/4"	24 lb
1"	4.75	6.69	14	1"	3/4"	24 lb
1 1/2"	9.0	9.06	18.35	1 1/2"	1"	80 lb
2"	9.96	9.65	20.55	2"	1"	80 lb

WCIS3 (Cast Iron)

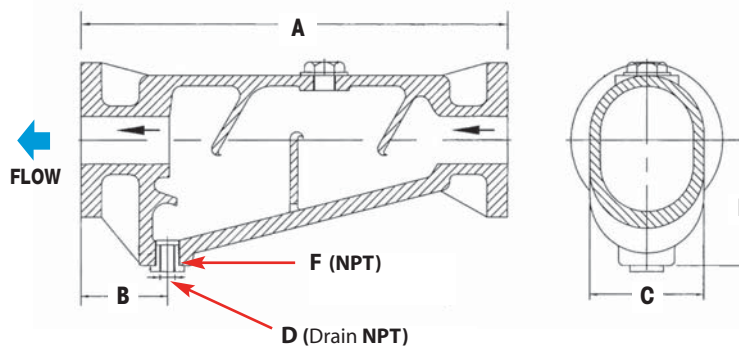

WCIS3 DIMENSIONS – Flanged connections (in./mm)							
Size	A	B	C	D	E	F	Weight
2 1/2"	15.94	4.13	5.71	3/4"	6.89	1 1/2"	67 lb
3"	18.90	4.53	5.91	1"	6.50	1 1/2"	87 lbs
4"	27.17	4.92	7.87	1"	8.27	1 1/2"	148 lbs

Pipeline Accessories

Freeze Protection Valve

WFPV

Stainless Steel

Model Code	WFPV-12-N
Sizes	1/2"
Connections	NPT
Body Material	Stainless Steel
PMO Max. Operating Pressure	200 PSIG
TMO Max. Operating Temperature	300°F

Typical Applications

The **WFPV** is used for freeze protection on pipes, valves, fittings, pumps, condensate systems, safety showers, fire lines, spray nozzles, freeze sensitive equipment or as backup protection on steam tracing lines.

How It Works

A thermostatic element senses water temperature in the valve. If the temperature falls below 35°F, the valve will modulate open allowing water to drain from the system. The valve will remain open as long as the water flowing by the sensing element is less than 40°F. When the water temperature rises above 40°F, the valve will close.

Features

- Corrosion resistant stainless steel body
- Long service life
- Narrow temperature band
- System pressures will not affect opening temperature

Sample Specification

The freeze protection valve shall have a stainless steel body and be actuated by a thermostatic element that senses water temperature. The unit shall feature a ram-type plug for a tight and reliable shut-off.

Installation

Unit should be installed in a vertical orientation with flow direction downward. For full details, see Installation and Maintenance Manual.

MATERIALS

Body	Stainless Steel, 303
O-Ring	EPDM
Plug	Stainless Steel
Spring	Stainless Steel, 302
Thermal Actuator	Stainless Steel

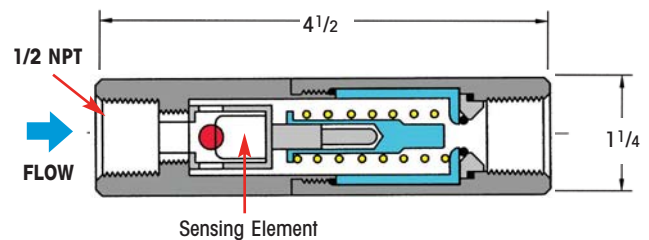
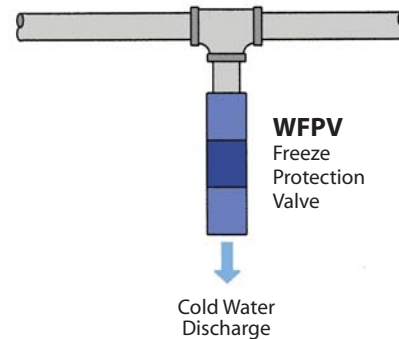
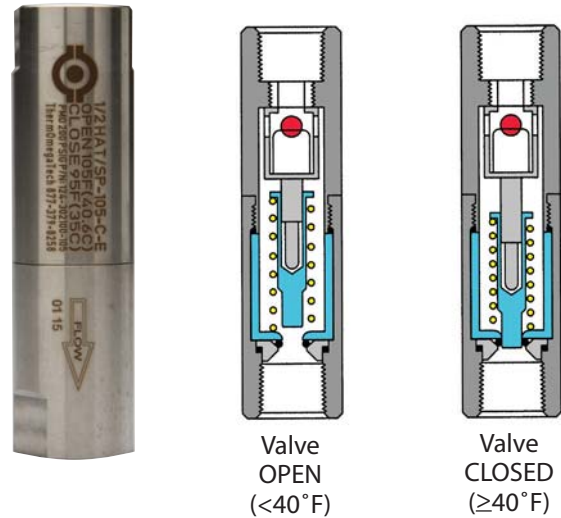

Weight: 0.9 lbs.

CAPACITIES – Water (lbs/hr)	
Inlet Pressure (PSIG)	Capacity (lbs/hr)
50	2475
75	3031
100	3500
125	3913
150	4287
175	4630
200	4950

Stainless Steel

Model Code	1/2"	WSPV-12-N
	3/4"	WSPV-13-N
Sizes	1/2", 3/4"	
Connections	NPT	
Body Material	Stainless Steel	
PMO Max. Operating Pressure	200 PSIG	
TMO Max. Operating Temperature	300°F	

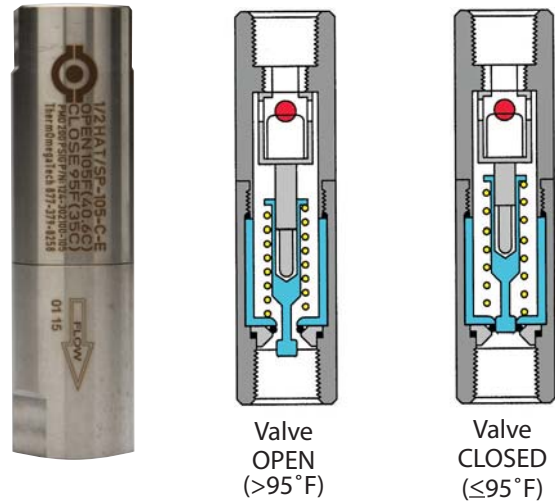

Typical Applications

The WSPV is used to protect personnel from accidental scalding by over-heated water or other liquids. Installations such as eye-wash stations and safety showers can become over-heated by piping exposed to solar radiation or a heat exchanger malfunction.

How It Works

When water temperature rises above 95°F, the thermal actuator modulates the valve open. If the water exceeds 105°F, the valve will go to full open position in order to discharge the over-heated water. When the water temperature returns to 95°F, the thermal actuator modulates the valve to close.

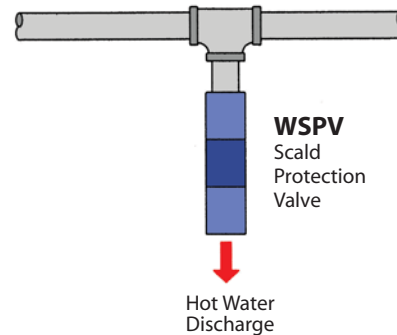

Features

- Corrosion resistant stainless steel body
- Long service life
- Narrow temperature band
- System pressures will not affect opening temperature

DIMENSIONS & WEIGHTS – inches / pounds			
Size NPT	A	B	Weight (lbs)
1/2"	1 1/4	4 1/2	0.9
3/4"	1 1/2	5 1/2	1.4

Sample Specification

The scald protection valve shall have a stainless steel body and be actuated by a thermal element that senses water temperature. The unit shall feature a ram-type plug for reliable and tight shut-off.

Installation

Unit should be installed in a vertical orientation with flow direction downward. For full details, see Installation and Maintenance Manual.

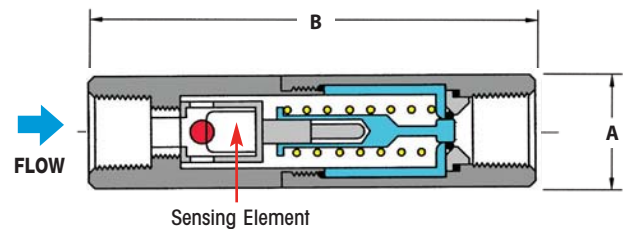

MATERIALS	
Body	Stainless Steel, 303
Seat Seal	PTFE
Plug	Stainless Steel
Spring	Stainless Steel, 302
Thermal Actuator	Stainless Steel

CAPACITIES – Water (lbs/hr)		
Inlet Pressure (PSIG)	Capacity (lbs/hr)	
	1/2"	3/4"
50	5,300	7,070
75	6,495	8,660
100	7,500	10,000
125	8,385	11,180
150	9,180	12,240
200	10,600	14,140

PIPELINE ACCESSORIES

Stainless Steel

Model	WSTTV	Stainless Steel
Sizes & Model Code	1/2"	WSTTV-12-N-SS
	3/4"	WSTTV-13-N-SS
	1"	WSTTV-14-N-SS
Connections	NPT	
Body Material	Stainless Steel	
Pressure Ratings	150 PSIG WSP	

WSP = Working Steam Pressure

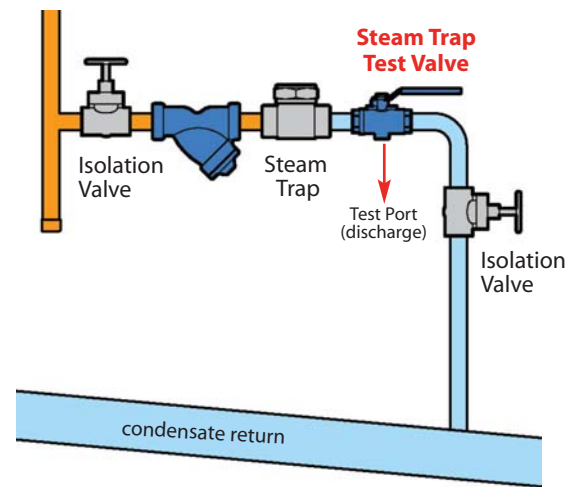
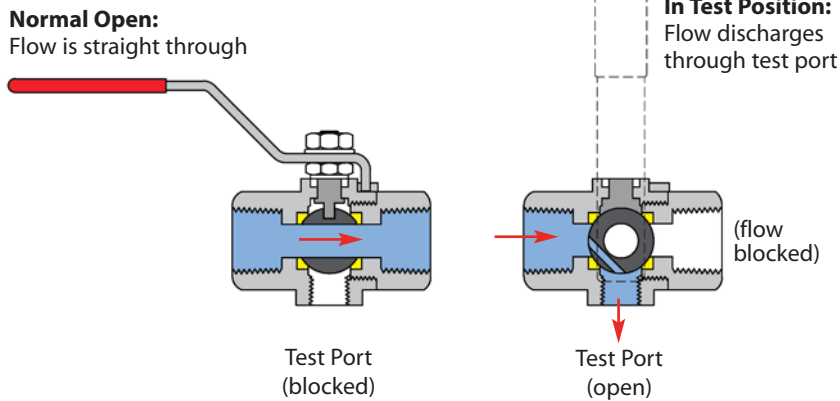

Application & How It Works

The **WSTTV** Steam Trap Test Valve offers simple, immediate, and visible diagnosis of any steam trap. Turning the handle 90° to the "Test" position will direct flow of steam trap out the test port for visual evaluation of discharge.

With the **WSTTV** Steam Trap Test Valve installed downstream of the trap and in the open position, the steam trap discharges normally. A quarter-turn of the handle repositions the specially designed ball and diverts the trap discharge through a port on the bottom of the valve. Discharge can then be observed and assessments made regarding the operation of the steam trap.

Features

- Seal welded construction
- Full stainless steel construction
- Fully compliant with ASME B16.34 & API 608
- NACE MR-01-75 compliant
- Standard locking stainless steel handles
- Single reduced bore/full porting (depending on size)

Installation

Test Valve to be mounted on the outlet side of the steam trap. Care should be taken to ensure that the discharge port will be positioned in such a manner so as to avoid danger to personnel. NOT AN ISOLATION OR STOP VALVE.

MATERIALS (Stainless Steel)

Description	150 PSI Rating
Body	CF8M
Ball	ASTM A276 Gr. 316 SS
Stem	ASTM A276 Gr. 316 SS
Seats (2)	R-TFM (Hostafilon)
Stem Packing	Graphite
Handle Assembly	300 Series SS