

DRAIN CLEANING

Drum Machines



K-7500 Drum Machine

For 3" to 10" (75-250mm) Lines.

- Recommend 5/8" (16 mm) cable for 3" (75 mm) to 6" (150 mm) drain lines up to 250' (76 m).
- Recommend 3/4" (20 mm) cable for 4" (110 mm) to 10" (250 mm) drain lines up to 250' (76 m).
- The performance, cable control, durability, and maneuverability demanded by professional users. Ideal for any tough job, such as roots – up to 250' (76 m).
- Cable spins at 200 RPM.
- Powerful, yet quiet, 600W universal motor and gearbox bear down as cutter engages tough obstructions.
- Provides audible and visual signals to operator.
- Inner-drum and ball bearing distributor arm work with motor/gearbox system to reduce chance of cable flip-over inside the drum.
- Main and inner drums won't rust, split or dent – ever, and clean easily for professional appearance. Main drum holds up to 100' (30.5 m) of 3/4" (20 mm) cable or 125' (38 m) of 5/8" (16 mm) cable.
- Powerful AUTOFEED® mechanism has grease fittings and an open design for easy maintenance; advances and retrieves cable up to 22' (6.7 m) per minute.
- Two position stair climber eases transport and loading – eliminates extra cost for loading wheels.
- Narrow profile allows machine to fit through bathroom doors.
- Handles adjust to desired height to ensure balanced transport.
- Includes RIDGID® PVC drain cleaning gloves and operator's manual.
- Approved by CSA to CSA and UL Standards (115 V only).

Machine Options

Catalog No.	Model No.	Description	Voltage		Weight	
			V	Ib.	kg	
59562	K-7500	Machine w/3/4" Pigtail and Standard Accessories	115	150	86.2	
60052	K-7500 C-100	Machine, Standard Accessories, and 3/4" x 100' Inner Core Cable.	115	272	123.7	
60062	K-7500 w/C-75	Machine, Standard Accessories, and 3/4" x 75' Inner Core Cable.	115	244	110.9	
61102	K-7500	Machine w/5/8" Pigtail and Standard Accessories	115	149	67.8	
61522	K-7500	Machine w/5/8" (16 mm) Pigtail and Standard Accessories	220	149	67.8	
61542	K-7500	Machine w/3/4" (20 mm) Pigtail and Standard Accessories	220	150	86.2	

Standard Equipment

Catalog No. Model No.	59562 K-7500	60052 K-7500 C-100	60062 K-7500 w/C-75	61102 K-7500	61522 K-7500	61542 K-7500
59360 - Tool Box	•	•	•	•	•	•
69250 - 3/16" Hex Wrench	•	•	•	•	•	•
70032 - RIDGID PVC Drain Cleaning Gloves	•	•	•	•	•	•
92485 - P-Trap Cutter, 3" (75 mm)	•	•	•	•	•	•
92495 - Spade Cutter, 1 3/4" (45 mm)	•	•	•	•	•	•
92500 - Retrieving Auger 2 3/8" (65 mm)	•	•	•	•	•	•
92505 - Sawtooth Cutter, 3" (75 mm)	•	•	•	•	•	•
92510 - Double Cutter, 2" (50 mm)	•	•	•	•	•	•
92520 - Double Cutter, 3" (75 mm)	•	•	•	•	•	•
92560 - 3/4" (20 mm) x 2' (50 mm) Leader	•	•	•	•	•	•
92830 - 4" Double Cutter (Blade Only)	•	•	•	•	•	•
92855 - 6" Double Cutter (Blade Only)	•	•	•	•	•	•
41697 - 3/4" (20 mm) x 100' IC Cable (30.5m)		•				
41212 - 3/4" (20 mm) x 75' IC Cable (22.9m)			•			

Cable Control & Performance – When Tool Engages Tough Obstructions

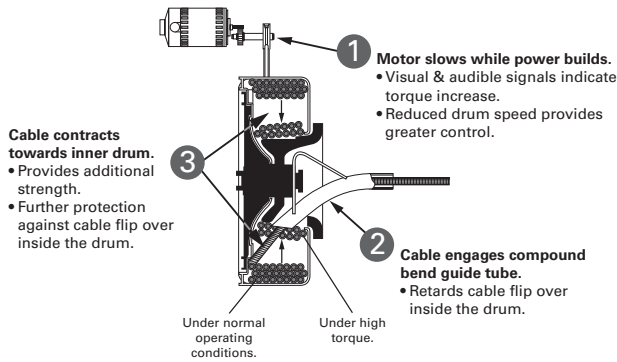

Accessories

	Catalog No.	Model No.	Description	Weight	
				lb.	kg
	41937	–	RIDGID Leather Drain Cleaning Gloves	1/2	0.20
	41992	A-75PF	C-100IC Kit w/Tools, 3/4" (20 mm) x 100' (30.5 m)	8	3.50
	49032	–	Front Guide Hose Assembly	3	1.30
	59360	A-3	Tool Box	5	2.30
	60032	A-75PF	AUTOFEED Assembly	10	4.50
	60037	A-75PF	AUTOFEED Spacers	10	4.50
	60042	A-7534D	Drum Assembly w/3/4" (20 mm) Pigtail	31	14.00
	60047	A-75DR	Drum Only	20	9.00
	61107	A-7558D	Drum Assembly w/5/8" (16 mm) Pigtail	30	13.60
	70032	–	RIDGID PVC Drain Cleaning Gloves	1/2	0.20
	31487	A-7570	5/8" (16 mm) Repair Splicer	1 1/2	43.00
	31492	A-7571	3/4" (20 mm) Repair Splicer	2	57.00
	92805	A-6582	5/8" (16 mm) Male Coupling	1	28.00
	92810	A-6583	5/8" (16 mm) Female Coupling	2	57.00
	92880	B-6840	3/4" (20 mm) Male Coupling	1	28.00
	92885	B-6841	3/4" (20 mm) Female Coupling	2	57.00

Inner Core (IC) Cables

	Catalog No.	Model No.	Description	Weight	
				lb.	kg
5/8" 16 mm	92460	C-25	5/8" (16 mm) x 25' IC Cable (7.6 m)	24	10.90
	92465	C-26	5/8" (16 mm) x 50' IC Cable (15.2 m)	43	19.50
	92470	C-27	5/8" (16 mm) x 75' IC Cable (22.9 m)	63	28.60
	43647	C-24	5/8" (16 mm) x 100' IC Cable (30.5 m)	84	38.10
3/4" 20 mm	92475	C-28	3/4" (20 mm) x 25' IC Cable (7.6 m)	30	13.90
	92480	C-29	3/4" (20 mm) x 50' IC Cable (15.2 m)	60	27.20
	41212	C-75	3/4" (20 mm) x 75' IC Cable (22.9 m)	93	42.50
	41697	C-100	3/4" (20 mm) x 100' IC Cable (30.5 m)	122	55.30

Hollow Core Cables

	Catalog No.	Model No.	Description	Weight	
				lb.	kg
5/8" 16 mm	32737	C-27HC	5/8" (16 mm) x 75' HC Cable (23)	52 3/4	23.90
	58192	C-24HC	5/8" (16 mm) x 100' HC Cable (30.5m)	70 1/2	32.10
3/4" 16 mm	47427	C-75HC	3/4" (20 mm) x 75' HC Cable (23 m)	75	34.00
	47432	C-100HC	3/4" (20 mm) x 100' HC Cable (30.5 m)	100	45.50

Leaders and Pig Tails

	Catalog No.	Model No.	Description	Weight	
				lb.	kg
	44117		3/4" (20 mm) Pigtail, 6' (1.8 m) Long	3 1/2	1.59
	44122		5/8" (16 mm) Pigtail, 4 1/2' (1.4 m) Long	2 1/2	1.13
	92555	T-458	5/8" (16 mm) x 2' (50 mm) Leader	2	0.85
	92560	T-468	3/4" (20 mm) x 2' (50 mm) Leader	2 3/4	1.25

Tools and Replacement Blades – Fit 5/8" (16 mm) and 3/4" (20 mm) Cables

	Catalog No.	Model No.	Description	Repl. Blade(s)
	51762	T-409	H-D Bulb Auger, 1 3/4" (45 mm)	–
	92485	T-403	P-Trap Cutter, 3" (75 mm)	92835
	92490	T-404	P-Trap Cutter, 3 1/2" (87 mm)	92840
	92495	T-406	Spade Cutter, 1 3/4" (45 mm)	92850
	92500	T-407	Retrieving Auger 2 9/16" (65 mm)	–
	92505	T-408	Sawtooth Cutter, 3" (75 mm)	92890
	92510	T-411	Double Cutter, 2" (50 mm)	92815
	92515	T-412	Double Cutter, 2 1/2" (65 mm)	92820
	92520	T-413	Double Cutter, 3" (75 mm)	92825
	92525	T-414	Double Cutter, 4" (110 mm)	92830
	92530	T-416	Double Cutter, 6" (150 mm)	92855
	92535	T-432	3-Blade Cutter 2" (50 mm)	92860
	92540	T-433	3-Blade Cutter 3" (75 mm)	92865
	92545	T-434	3-Blade Cutter 4" (110 mm)	92870
	92550	T-436	3-Blade Cutter 6" (150 mm)	92875

C-24, C-25, C-26, C-27, C-28, C-29, C-75, C-100, C-27HC, C-24HC, C-75HC and C-100HC