

The HS31 is a sample/drain valve used to extract a fresh sample while providing tight shutoff and high pressure and temperature capabilities. It is designed as a solution to routine and difficult fluid sampling applications including viscous liquids, slurries and other products that tend to solidify when cooled or exposed to the atmosphere.

The HS31 design features a reciprocating stem that unplugs the sample section as it opens. Opening the valve moves the plunger into the pipeline or vessel to remove any debris or sediment, assuring that a fresh sample enters the valve body. The valve also features two standard outlet ports. This allows the user to thread a sample cylinder, tube fitting, or piping into one outlet while using the additional outlet for check valve or bleed valve installation, clean out or purging connections.

For shutoff considerations, the HS31 can be provided with metal-to-metal seats or optional dual seating. The dual seat consists of a retained KEL-F seat installed in the inlet end of the valve body, backed up by a secondary metal-to-metal seat directly downstream.



### Features and Benefits

- **Wide Material Selection Suits a Variety of Applications and Services:** Barstock body available in a large selection of materials including Carbon Steel, Stainless Steel, Monel, Alloy 20, Hastelloy B, and Hastelloy C.
- **Reciprocating Stem:** Opening the HS31 moves the plunger into the pipeline or vessel to remove any debris or settlement. This allows a fresh sample to enter the valve body.
- **Dual Seating Option:** The HS31 is available with metal-to-metal seats or optional dual seating. The dual seat consists of a retained Kel-F seat installed in the inlet end of the valve body, backed up by a secondary metal-to-metal seat directly downstream.
- **Two Outlet Ports Standard:** A sample cylinder, tube fitting, or piping is threaded into one outlet, with an additional outlet provided for check valve or bleed valve installation, cleanout or purging connections.

## Dimensions

Weight: 5.5 pounds (2,5 kgs)  
 Hard Seat Orifice: 0.628"  
 Soft Seat Orifice: 0.500"

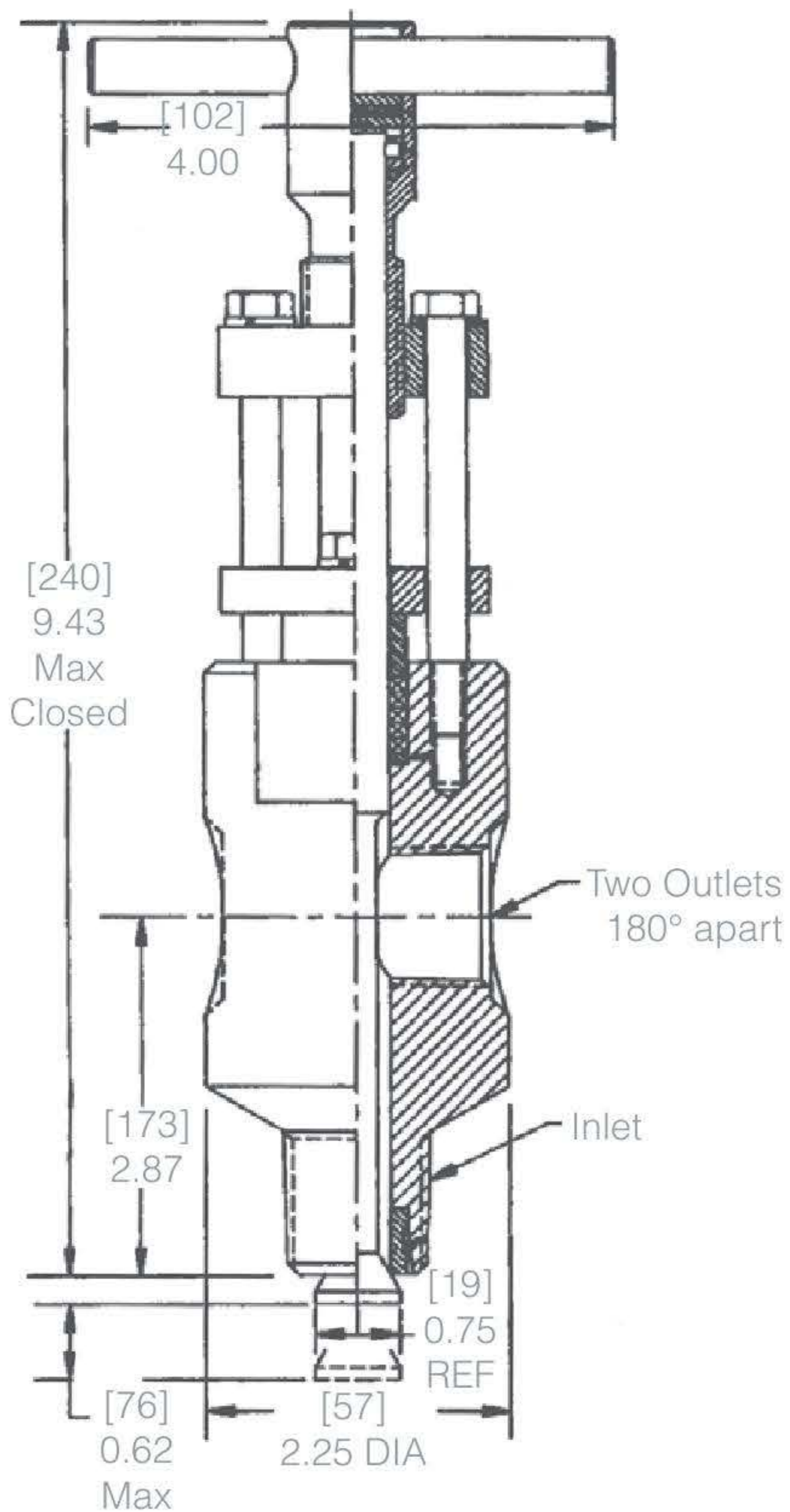

## Flow Schematic

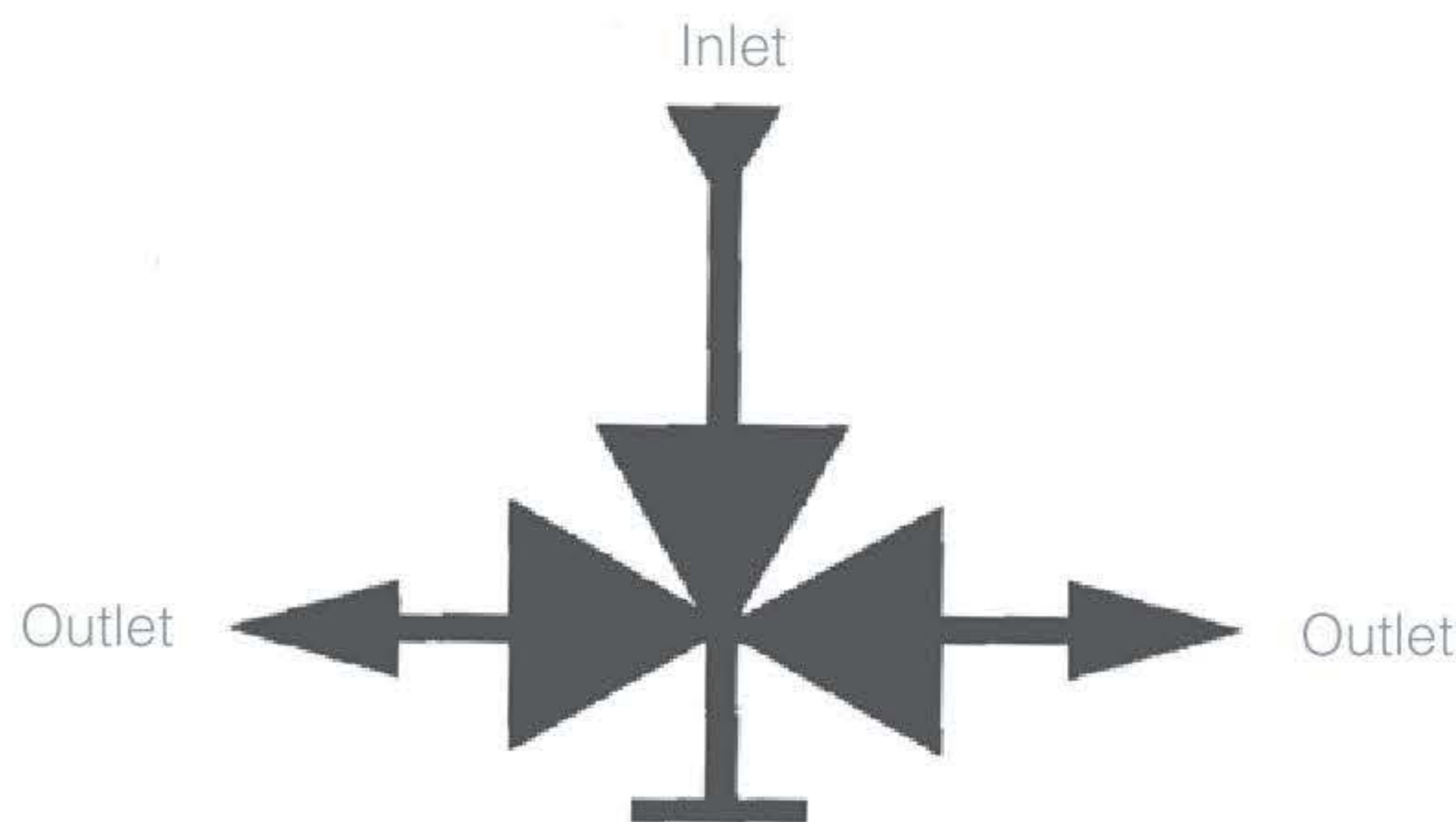

## Seat Configurations

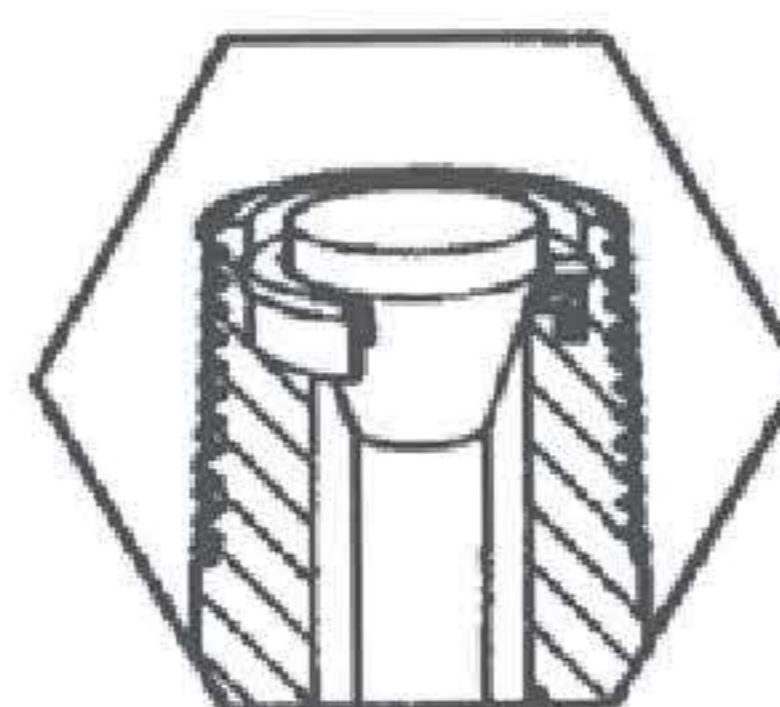

Dual Seating



Metal-to-Metal Seating  
(Insert Shown)

How to Order									
Model Number	Seat Configuration	Body Material	Inlet Size	Inlet Type	Outlet Size	Outlet Type	Stem Material	Seat Material	Packing
HS31	1 = Hard	S = Carbon Steel (A105)	4 = 3/4" *	1 = MNPT**	3 = 1/2" x 1/2"	1 = FNPT	2 = 316 SS	1 = Integral	2 = TFE-Chevron
	2 = Soft Seat**	U = Stainless Steel (316)	5 = 1"	2 = MSW*	4 = 3/4" x 3/4"	A = HB241		2 = 316 SS	3 = Graphite
			6 = 1-1/2"		9 = 1/2" x 3/4"	R = Plug (1)		5 = KEL-F Soft**	

\* Hard seat insert only  
 \*\* 1" - 1-1/2" MNPT only

## Sample Ordering Schematic

HS31	1	U	5	1	9	1	2	1	2
------	---	---	---	---	---	---	---	---	---