

Purge/Drain Ports

Purge ports are 1/8" FNPT plugged access ports on the inlet side of the shutoff valves on all Hex manifolds (except HM93/94). They allow for easy draining of impulse lines or the introduction of a purge gas or liquid seal without requiring additional tees and fittings.

To order, specify 'OL' in option spaces 14 & 15 of the Hex model number.

Hex 1/8" Test Ports allow transmitter vent/test access, and are located on the outlet side of the manifold (usually behind the shutoff valves). **To order, specify 'OK' in option spaces 14 & 15 of the Hex model number. (Note: not available on HM93).**

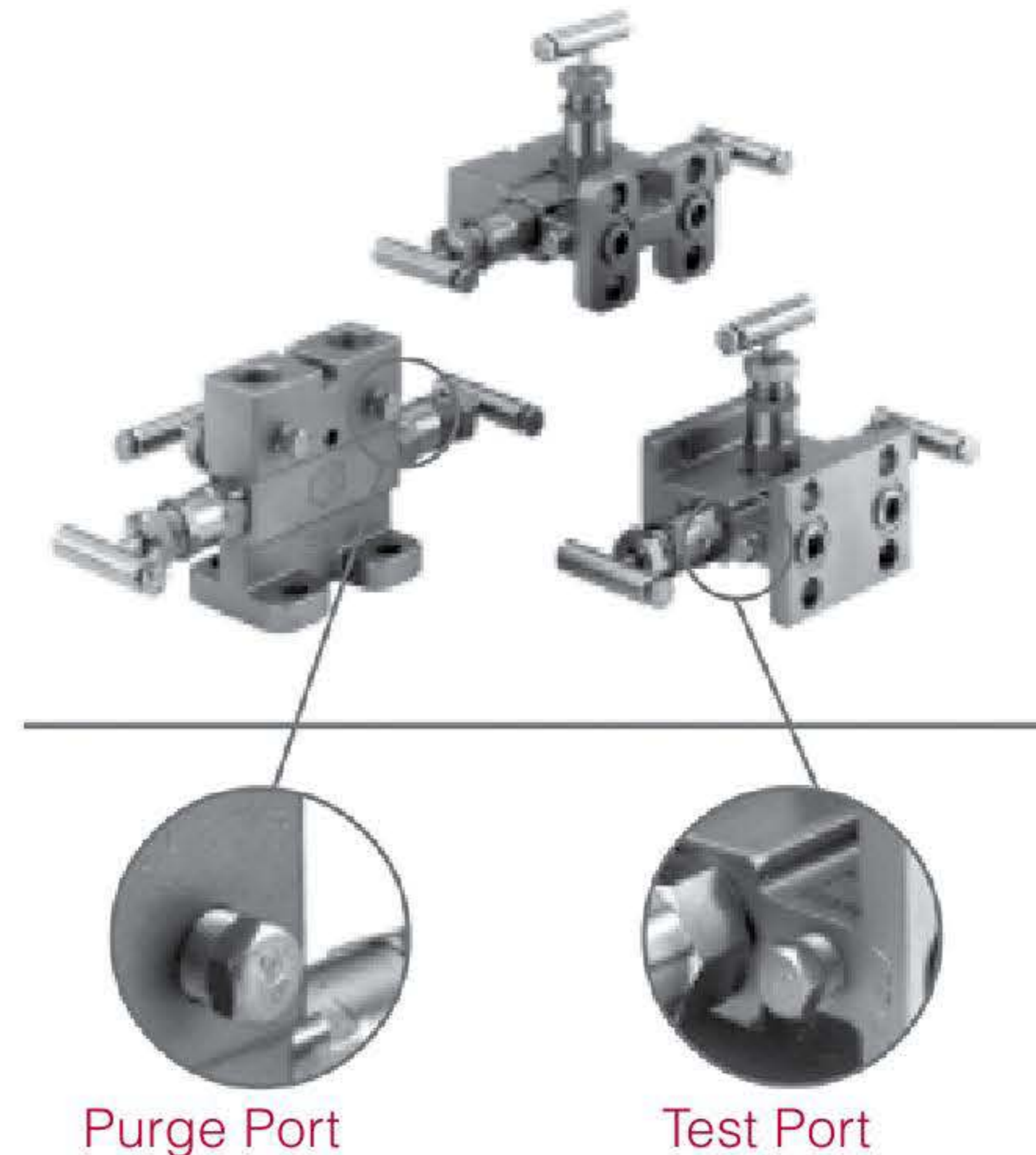

Integral Tube Fittings

If you use tubing with your instrument valves, you can save time and installation labor by specifying your Hex valves with the integral tube fitting option. Installation is quick and easy. An inverted nut and ferrule is pre-assembled into the valve so you simply insert the tubing and tighten.

They are available in single ferrule and double ferrule designs in Carbon Steel (ASTM A108) or 316 Stainless Steel (ASTM A479) to correspond with the valve body material.

The integral tube fitting option is available on Hex models HM10, HM13, HM18, HM45, HM50, HM53, HM57, HM58, and HN49.



Hex Head Plugs

Barstock hex head plugs are available in Stainless Steel or Carbon Steel in the following sizes:

Part Number	Size
10019-000-**	1/8"
10020-000-**	1/4"
10021-000-**	3/8"
10022-000-**	1/2"
10023-000-**	3/4"

Insert material code:
S1 for Carbon Steel, T1 for 316 Stainless Steel, or M1 for Monel



Safety Handles

Safety Handles are utilized when there are concerns for safety, tampering or space limitations. A simple alternative to conventional T-handles, a tool (wrench or screwdriver) is required to open or close the valve. The compact design also prevents accidental valve actuation due to clothing snags or bumps. **To order, add a '5' in option space 14 of the model number.**



Gauge Mounting Kit

The Hex HK11 Universal Gauge Mounting Kit provides rigid mounting of a gauge while allowing simple maintenance and calibration. It enables horizontal or vertical mounting while providing additional support for the gauge. It also reduces the installation radius and number of components used, eliminating much of the cost associated with the large number of parts required for conventional gauge mounting.

The Hex method consists only of a bracket and tubing with connectors, and provides stable support of the gauge while eliminating the need for field fabrication. To order, build a model number by selecting a digit from each of the boxes below.

Gauge Mounting



Hex Mounting Kit Components



How to Order

Model Number	Configuration	Tube Fittings/Material	Valve Outlet	Gauge Inlet
HK	1 = 4-1/2" gauge	1 = 4-1/2" gauge	1 = 1/4" FNPT	1 = 1/4" MNPT
	2 = 6" gauge	2 = 6" gauge	2 = 1/2" FNPT	2 = 1/2" MNPT
			3 = 3/4" FNPT	3 = 3/4" FNPT
				4 = 1/2" FNPT

Sample Ordering Schematic

HK	1	1	2	4
----	---	---	---	---

Hex Valve offers simple solutions for the winterization or heating requirements of your process instrumentation, including both differential pressure and gauge pressure instruments, as well as maintaining temperature on sample applications.

Steam Blocks

Simple modular method of steam heating field instruments and eliminating the tubing loops used for traditional tracing.

With the block directly attached to the manifold, heat transfer is consistent, reliable, and the instrument is left free for simple removal for maintenance.

The stem block's compact design allows easy insulation through the use of a variety of commercially available enclosures.



Integral Steam Tracing

Valves with built-in steam passages are available for critical temperature maintenance of gauge pressure, sampling or differential pressure applications that require greater heat transfer rates.



Steam Jacketed Sample/Drain Valve

Integrally-traced sample valves are available for use on sampling systems that require high temperatures to ensure a consistent liquid sample.



Steam Trace Block

The steam trace block option is specified for processes that can thicken or solidify at ambient temperatures as is common with many chemical and petroleum products. It is also used on field-mounted transmitters and instruments to prevent weather conditions from affecting operation.

The steam block has a 1/4" NPT opening on each end and is attached to the underside of the manifold with two bolts located on a 1" center-to-center dimension. It is available as an option on the following models:

- HIM10 • HM13 • HM14 • HM16
- HIM18 • HM20 • HM40 • HM45
- HIM50 • HM53 • HM54 • HM55
- HIM56 • HM57 • HM58 • HM56

How To Order

Hex steam trace block option is easy to order. From the options shown below, add the appropriate digits to the end of your specific valve model number.

- Steam Block: add 'N'
- Steam Block & Mounting Bracket: add '7'

Integral Steam Tracing

Integrally steamed trace manifolds are available for those critical temperature, gauge pressure, or differential pressure instruments where greater heat transfer is required. These manifolds features built in steam passages within the manifold body to ensure maximum heat transfer capabilities. **For drawings or ordering information, please contact our factory.**

Steam Jacketed Sample Valve

The steam jacketed HS31 sample valve is a solution to routine or difficult sampling problems. It is used to extract a fresh sample while providing tight shutoff, high pressure and temperature capabilities, and a reciprocating stem that unplugs the sample section as it opens.

The steam-jacketed option is typically used on viscous liquids, slurries and products that tend to solidify when cooled or exposed to normal ambient conditions. For drawings or ordering information, please contact our factory.

