

Support Valve Series

**Tangential Flow Air Eliminator
Thermally Activated Valve
Vacuum Priming Valve
Pump Protector**



Crispin
Since 1905

Crispin Multiplex Manufacturing Co. • 600 Fowler Avenue • Berwick, PA 18603 • 1-800-AIR-VALV
T: (570) 752-4524 • F: (570) 752-4962 • www.crispinvalve.com • sales@crispinvalve.com



AE SERIES

Support Valves

Tangential Flow Air Eliminator

Service Applications

- Hydronic heating system
- Petroleum transfer
- Air & gas lines
- Irrigation systems

Features Include

- ASME constructed tank
- 125 PSIG design pressure
- Carbon steel, Galvanized or Stainless Steel
- Efficient tangential flow design
- Air or exhaust gas is piped away
- Sizes 2" thru 24"*
- 2" and 2 1/2" sizes have NPT connections
- 3" and larger sizes are flanged
- Optional Inlet Strainer

The CRISPIN Tangential Flow Air Eliminator separates large or small quantities of air from liquid systems while the system is in operation. The tangential flow design slows the velocity of liquid through the pipe, allowing greater air separation from the media.

CRISPIN provides a wide range of Air Release Valve orifice sizes to suit your application. This can be accommodated thru the selection of the proper valve based upon the maximum anticipated air collection volume. Refer to CRISPIN Pressure Air Release Valve sizing information.

The CRISPIN Air Eliminator is typically installed inline downstream from the pump, but upstream from flow meters.

The Air Release Valve can include an isolation valve between the tank and the Air Release valve. This will allow system operation to remain uninterrupted, if valve servicing is required.

Typical configurations can include any size CRISPIN Air Release Valve to accommodate the system's anticipated air volume.



Standard Materials

- ASME code carbon steel tank with cast iron body and stainless steel trim Air Release Valve

Optional Materials

- Galvanized Steel
- Stainless Steel
- Carbon steel internally lined with bitumastic tank solution
- Grooved End inlet and outlet are available on all sizes
- Inlet strainer is optional

* For sizes above 14", please contact the factory.



AE SERIES

Tangential Flow Air Eliminator

MODEL NO.	A	B	C	D	E	F	G STRAINER	H	J	K	L	M DIA. PIPE	P	R	WEIGHT
AE20	12	19 1/2	22 1/2	16 5/8	5 1/2	2 1/8	2	2	4 5/16	1 1/4	1	2	16 1/4	9 1/2	71
AE25	12	19 1/2	22 1/2	16 5/8	5 1/2	2 3/8	2 1/2	2 1/2	4 1/16	1 1/4	1	2 1/2	16 1/2	9 1/2	86
AE31	12	19 1/2	22 1/2	19 3/4	5 3/4	2 1/2	3	3	3 3/4	1 1/4	1	3	17 1/8	9 1/2	91
AE41	14	29	32	21 3/4	9 1/8	2 1/2	4	4	4 1/4	1 1/2	2	4	19 1/2	11 1/2	134
AE51	14	29	32	21 3/4	9 1/8	2 1/2	5	5	3 3/4	1 1/2	2	5	19 3/4	11 1/2	161
AE61	20	41	44	28	13 1/4	2 1/2	6	6	6 1/4	2	2	6	25	18	259
AE81	20	41	44	28	13 1/4	3	8	8	5 3/16	2	2	8	29	18	404
AE101	30	58	60 1/2	41	19	3 1/2	10	10	9 1/8	2	2	10	25 1/2	24	708
AE121	30	58	60 1/2	41	19	3 1/2	12	12	8 1/8	2	2	12	26 1/2	24	792
AE141	36	75 1/2	78	46 3/8	22	3 1/2	14	14	10 3/16	2	2	14	42 1/4	30	1538

Specifications and materials are subject to change without notice.
For sizes about 14", please contact the factory.

Valve Diagram

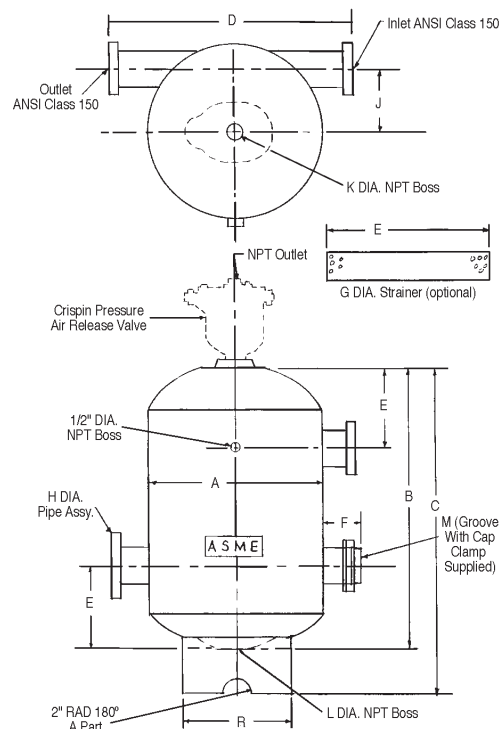



TAV SERIES

Support Valves

Crispin Thermally Activated Valve

Service Applications

- Freeze protection
- Scald protection
- Steam trap/ drip trap
- Heat tracing of valves and pumps



Design Characteristics

Actuator: The actuator is located on the downstream side at the plug and seat. This arrangement permits valve sensitivity to critically low ambient temperatures.

Flow Control: The orifice and control port are sized to effectively regulate flow for better control. Specific application requirements can be accommodated by specifying the desired flow coefficient.

Materials: The corrosion resistant ram type plug and seat provide a more effective shut-off than a metal-to-metal seat.

Installation: CRISPIN TAV valves are installed with a pipe wrench to two optional pipe sizes.

The Crispin Thermally Activated Valve offers freeze protection for valves, pipelines and ancillary piping equipment. It will discharge liquid when the 35° F set point is reached. The TAV also offers scald protection for eyewash stations and safety showers, with solar heating of pipe systems. It operates as a steam and drip trap, draining condensate and closing again when steam passes through. It also offers steam tracing of valves or pumps by regulating condensate outflow temperature. The TAV responds to temperature differentials by means of a thermal actuator placed in the fluid stream. When temperature increases above the set point, the wax in the actuator undergoes a phase change, forcing the valve open. When liquid of the desired temperature is sensed, the valve modulates to control the discharge rate. In all cases, the valve will open or close as the temperature changes around the valve set point.

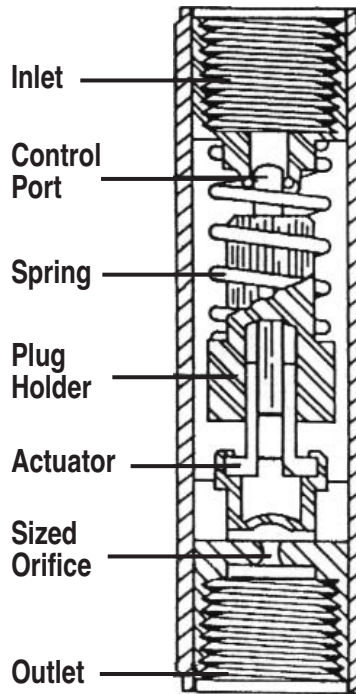

Standard Materials

- Body:** 303 & 304 Stainless Steel
- Seat:** High Temperature Teflon®
- Plug:** 316 Stainless Steel
- Spring:** Stainless Steel
- Plug Holder:** Brass

Specifications

- Model TAV5:** 1/2" NPT Inlet/Outlet
- Pressure:** 300 PSIG MAX.
- Length:** 4 1/2" **Diameter:** 1 1/8"
- Weight:** 12oz.
- Cv:** 0.8 standard; 1.8 and 0.2 available

Temp. Set Points	35°F	95°F	100°F	120°F	180°F	210°F	240°F
Freeze Protection	X						
Steam Application					X	X	X
Scald Protection		X	X	X			
Heat Tracing	X		X	X	X	X	X

When ordering, please specify model number and set point temperature



VP/VSL SERIES

Crispin Vacuum Priming Valve

Service Applications

- Used in conjunction with a vacuum source when priming a centrifugal pump
- Prevents liquid from getting to a vacuum source
- Functions as a clean water & sewage priming valve

Crispin Vacuum Priming Valves are used in conjunction with a vacuum source when priming a centrifugal pump. As the vacuum pump lowers the pressure at the centrifugal pump, atmospheric pressure pushes the liquid in the sump or wet well up the section leg of the pump. When the liquid reaches the Vacuum Priming Valve, the valve closes and prevents the liquid from getting to the vacuum source. As residual air collects, the liquid level in the valve is displaced. The float drops and the air is drawn out by the vacuum source. The re-entering liquid buoys the float to seal the valve.

Sewage Vacuum Priming Valves provide the same function as clean water priming valves, with the exception of an elongated body to handle the sewage solids.

Dimensions & Weight Information

SIZE OF VALVE	CLEAN WATER					SEWAGE		
	1"	2"	2 1/2"	3"	4"	2"	3"	4"
A	9 3/4	10 1/8	11 1/2	12 1/2	14 1/4	9 3/4	9 3/4	9 3/4
B Scwd Connection	9 1/8	10 1/2	11 1/8	13 1/2	16 5/8	21 5/8	21 5/8	21 5/8
Add to "B" for Vacuum Check	2 1/2	2 1/2	3 3/4	3 3/4	3 3/4	2 1/2	2 1/2	2 1/2
Weight Scwd. Connection	23lbs	45lbs	58lbs	87lbs	132lbs	49lbs	49lbs	49lbs
Size Outlet	1/2" NPT	1/2" NPT	1" NPT	1" NPT	1" NPT	1/2"	1/2"	1/2"

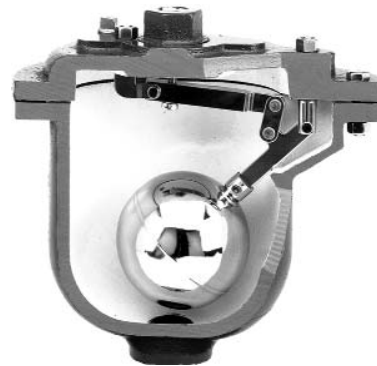

Sewage

SIZE OF VALVE	2"	3"	4"
Model No. Screwed Inlet	VSL20	VSL30	VSL40
w/ Back Flush Attachments	VSL20B	VSL30B	VSL40B

Model Information for Clean Water

SIZE OF VALVE	1"	2"	2 1/2"	3"	4"
Model No.	VPL10	VPL20	VP250	VP30	VP40
Screwed Inlet		VPL10A		VPL20A	
125# Flanged Inlet		VPL21	VP251	VP31	VP41
250# Flanged Inlet		VPL22	VP252	VP32	VP42
Trim	S/S	S/S	IBBT	IBBT	IBBT

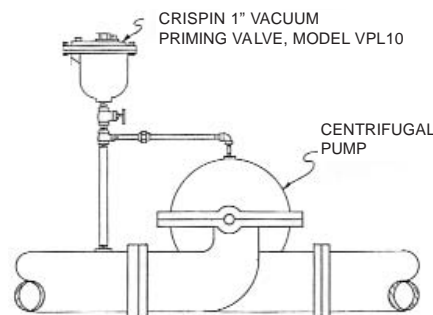



Support Valves

Crispin Pump Protector

Product Function

- **Helps protect pumps when an application becomes airbound**
- **Can also open or close an electric circuit of an alarm system**

The water level control switch is mounted in parallel with the air release valve. As the liquid level rises in the valve body, the float is buoyed and seats the valve. The float switch rises, and either opens or closes line contacts. Air is released continuously and automatically while the pump is in operation.

If the air release valve should malfunction and not release air, the pump could become air bound and dramatically lose efficiency or become damaged. A water level control switch would prevent this from occurring, because it too would become air bound, causing its float switch to drop with the receding liquid level. This change in the float switch position will open the pump circuit and signal an alarm.



Potable Water Units

MODEL	INLET	WEIGHT	HEIGHT	WIDTH
PL10/WLC	1"	76 lbs.	15"	21 1/2"
PL10A/WLC	2"	79 lbs.	16"	22"
PL20/WLC	2"	120 lbs.	16"	22"
P30/WLC	3"	235 lbs.	19"	24"
P40 /WLC	4"	285 lbs.	22 "	26 "

Sewage Units

SL20/WLC	2"	105 lbs	27"	22"
SL30/WLC	3"	197 lbs.	28"	23"
SL40 / WLC	4"	202 lbs.	28"	24"

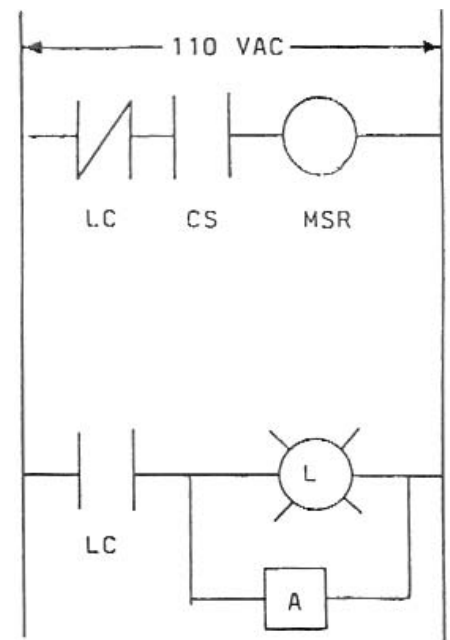

- MSR** Pump Motor Starting Relay
- CS** Control Switch
- LC** Water Level Control Switch
- L** Warning Light
- A** Alarm

Submittal Sheet for AE Series

2"-4" Tangential Flow Air Eliminator

Manufactured in compliance with ANSI/AWWA C512

Date: October, 2001



SUBMITTAL SHEET FOR AE SERIES

Parts List

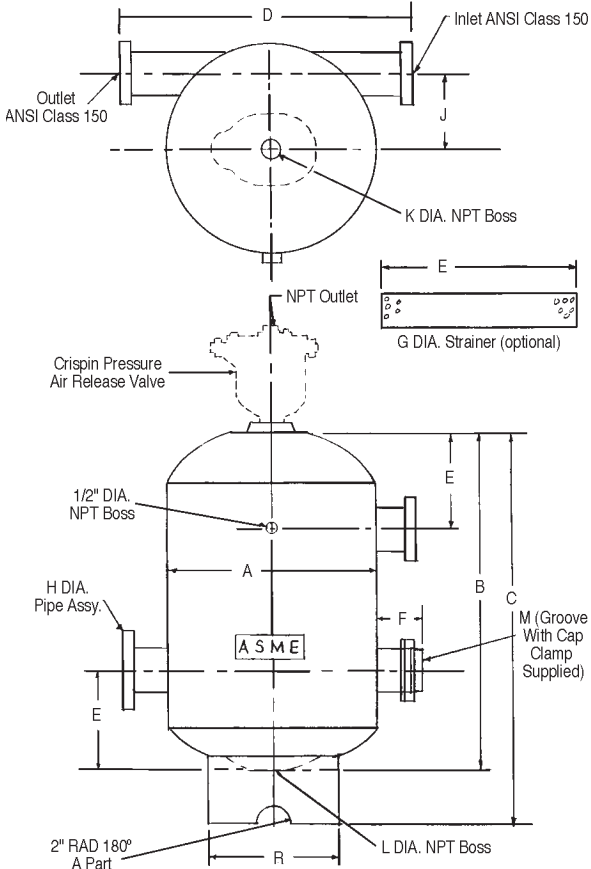

ITEM	DESCRIPTION	MATERIAL
1N	SEAT	PVC
2N	VALVE	BUNA-N RUBBER
3	PLUNGER NUT	BRASS
4	PLUNGER	BRASS
5	VALVE FULCRUM	STAINLESS STEEL
5A	FULCRUM BOLT	STAINLESS STEEL
6	VALVE LEVER	STAINLESS STEEL
7	LINK	STAINLESS STEEL
8	BALL FULCRUM	STAINLESS STEEL
9	FLOAT	STAINLESS STEEL
9A	FLOAT ROD	STAINLESS STEEL
10	BALL LEVER	STAINLESS STEEL
11	BEARING PIN	BRASS
12	BEARING PIN	BRASS
13	SCREW	STAINLESS STEEL
14	BEARING PIN	STAINLESS STEEL
14A	COTTER PIN	STAINLESS STEEL
15	BEARING PIN CLIP	STAINLESS STEEL
17	BOLT	STEEL
18	NUT	STEEL
19	TOP	CAST IRON
20	FLANGE	CAST IRON
21	BODY	CAST IRON
22	FULCRUM WASHER	FIBER
22A	FULCRUM WASHER	FIBER
23	SEAT GASKET	BUNA-N RUBBER
24	FLANGE GASKET	ARMSTRONG N-8092
29	PLUG	BRASS

CONNECTING PARTS LIST

CP1	NIPPLE	STEEL
CP2	GATE VALVE	BRASS

TANK PARTS LIST

T1	AIR ELIMINATOR	CARBON STEEL
----	----------------	--------------

Valve sizes less than or equal to 4" have a 1/4" Orifice • Valves sizes greater than 6" have a 5/16" Orifice

Size Specifications

MODEL NO	A	B	C	D	E	F	G STRAINER	H	J	K	L	M DIA. PIPE	P	R	WGT.
AE20	12	19 1/2	22 1/2	16 5/8	5 1/2	2 1/8	2	2	4 5/16	1 1/4	1	2	16 1/4	9 1/2	71
AE250	12	19 1/2	22 1/2	16 5/8	5 1/2	2 3/8	2 1/2	2 1/2	4 1/16	1 1/4	1	2 1/2	16 1/2	9 1/2	86
AE31	12	19 1/2	22 1/2	19 3/4	5 3/4	2 1/2	3	3	3 3/4	1 1/4	1	3	17 1/8	9 1/2	91
AE41	14	29	32	21 3/4	9 1/8	2 1/2	4	4	4 1/4	1 1/2	2	4	19 1/2	11 1/2	134
AE51	14	29	32	21 3/4	9 1/8	2 1/2	5	5	3 3/4	1 1/2	2	5	19 3/4	11 1/2	161
AE61	20	41	44	28	13 1/4	2 1/2	6	6	6 1/4	2	2	6	25	18	259
AE81	20	41	44	28	13 1/4	3	8	8	5 3/16	2	2	8	29	18	404
AE101	30	58	60 1/2	41	19	3 1/2	10	10	9 1/8	2	2	10	25 1/2	24	708
AE121	30	58	60 1/2	41	19	3 1/2	12	12	8 1/8	2	2	12	26 1/2	24	792
AE141	36	75 1/2	78	46 3/4	22	3 1/2	14	14	10 3/16	2	2	14	42 1/4	30	1538



Submittal Sheet for TAV Series

3/8" & 1/2" Thermally Activated Valve

Date: October, 2001

Parts List

ITEM	QTY.	DESCRIPTION	MATERIAL	ASTM
1	1	BODY	STAINLESS STEEL	A312
2	1	INLET FITTING	STAINLESS STEEL	A276
3	1	RESILIENT SEAT	PTFE	N/A
4	1	OPERATING SPRING	STAINLESS STEEL	A313
5	1	RAM TYPE PLUG	STAINLESS STEEL	A276
6	1	THERMAL ACTUATOR	PARAFFIN WAX	N/A
7	1	ACTUATOR CARRIER	F.M. BRASS	B16
8	1	OUTLET FITTING	STAINLESS STEEL	A276
9	1	SIZED ORIFICE	F.M BRASS	B16

Size Specifications

MODEL	INLET SIZE	OUTLET SIZE	A	B	WEIGHT
TAV-5	1/2" NPT	1/2" NPT	1.13	4.50	7

Temp. Set Points	35°F	95°F	100°F	120°F	180°F	210°F	240°F
Freeze Protection	X						
Steam Application					X	X	X
Scald Protection		X	X	X			
Heat Tracing	X		X	X	X	X	X

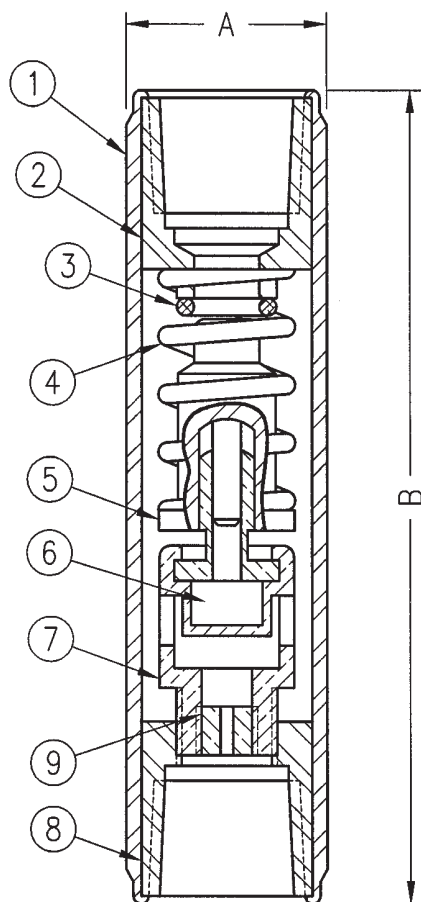

When ordering, please specify model number and set point temperature

Design Characteristics

Actuator: The actuator is located on the downstream side at the plug and seat. This arrangement permits valve sensitivity to critically low ambient temperatures.

Flow Control: The orifice and control port are sized to effectively regulate flow for better control. Specific application requirements can be accommodated by specifying the desired flow coefficient.

Materials: The corrosion resistant ram type plug and seat provide a more effective shut-off than a metal-to-metal seat.

Installation: CRISPIN TAV valves are installed with a pipe wrench to two optional pipe sizes.