

The HB50 features a fully packed and backseated block valve along with a bleed valve with directional discharge tube and stem stop. With a gauge or transmitter threaded into its outlet, the HB50 will allow pressure to be bled and blocked for simplified instrument removal. The discharge tube enables the technician to direct the high pressure fluid away from himself before changing the instrument. The HB50 can also be threaded into a Hex Primary Block Valve (such as the Hex HG46) to provide secondary block and bleed functions on multiple instrument installations.

The HB51 is similar to the HB50 but utilizes a bleed screw in lieu of a bleed valve. HB24: features an easy to use "T" handle plus directional discharge/drain/tube.



Features and Benefits

- Cost savings by reducing number of components and leak points.
- Compact design features two valves in one to utilize less space.
- Non-rotating tip eliminates seat galling and provides a bubble-tight shut off.
- Packing below the threads prevents lubricant wash out and corrosion.

Pressure and Temperature Chart

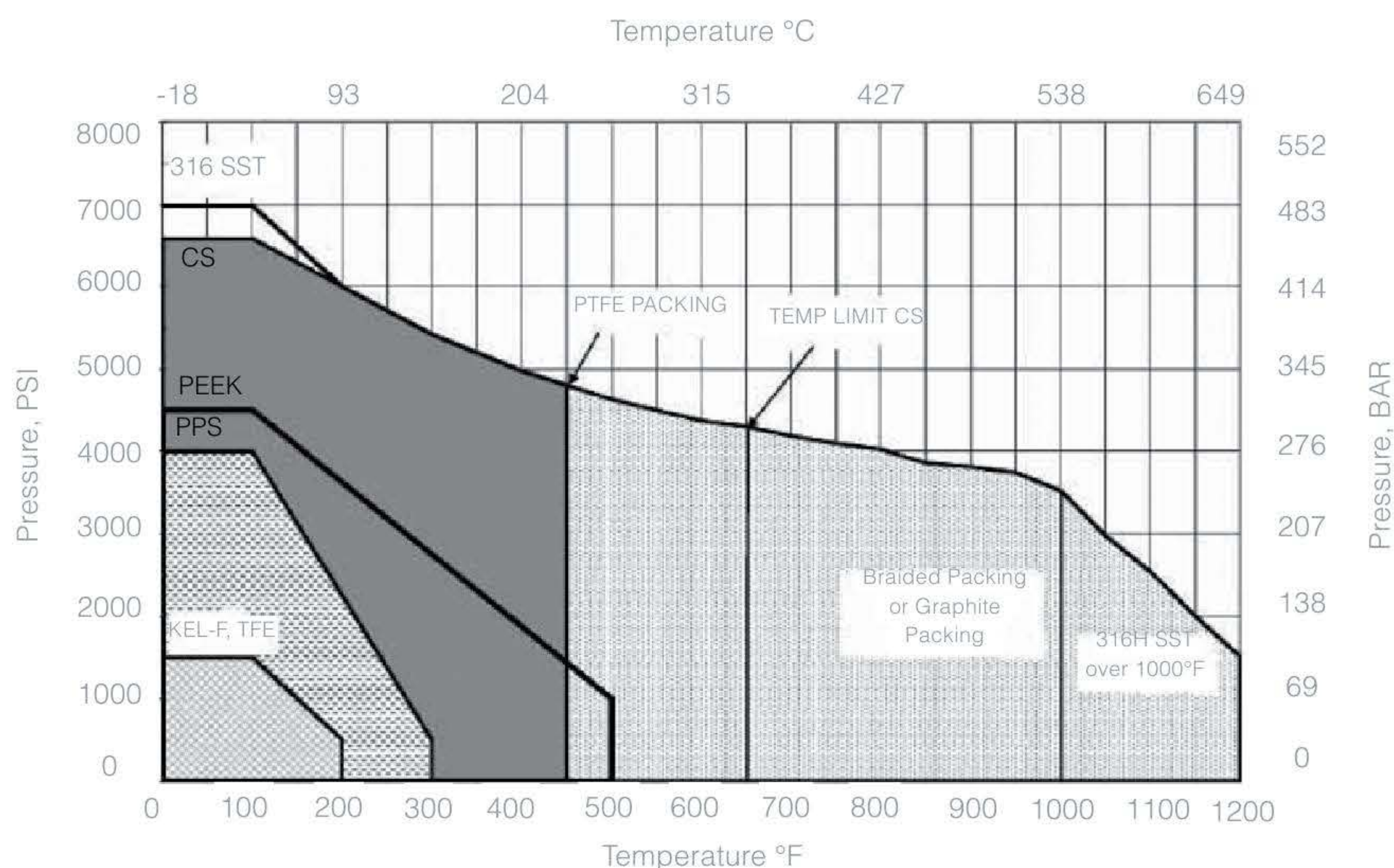

Dimensions

Orifice Size: 0.19"
Weight: 1.81 pounds
0,82 kgs

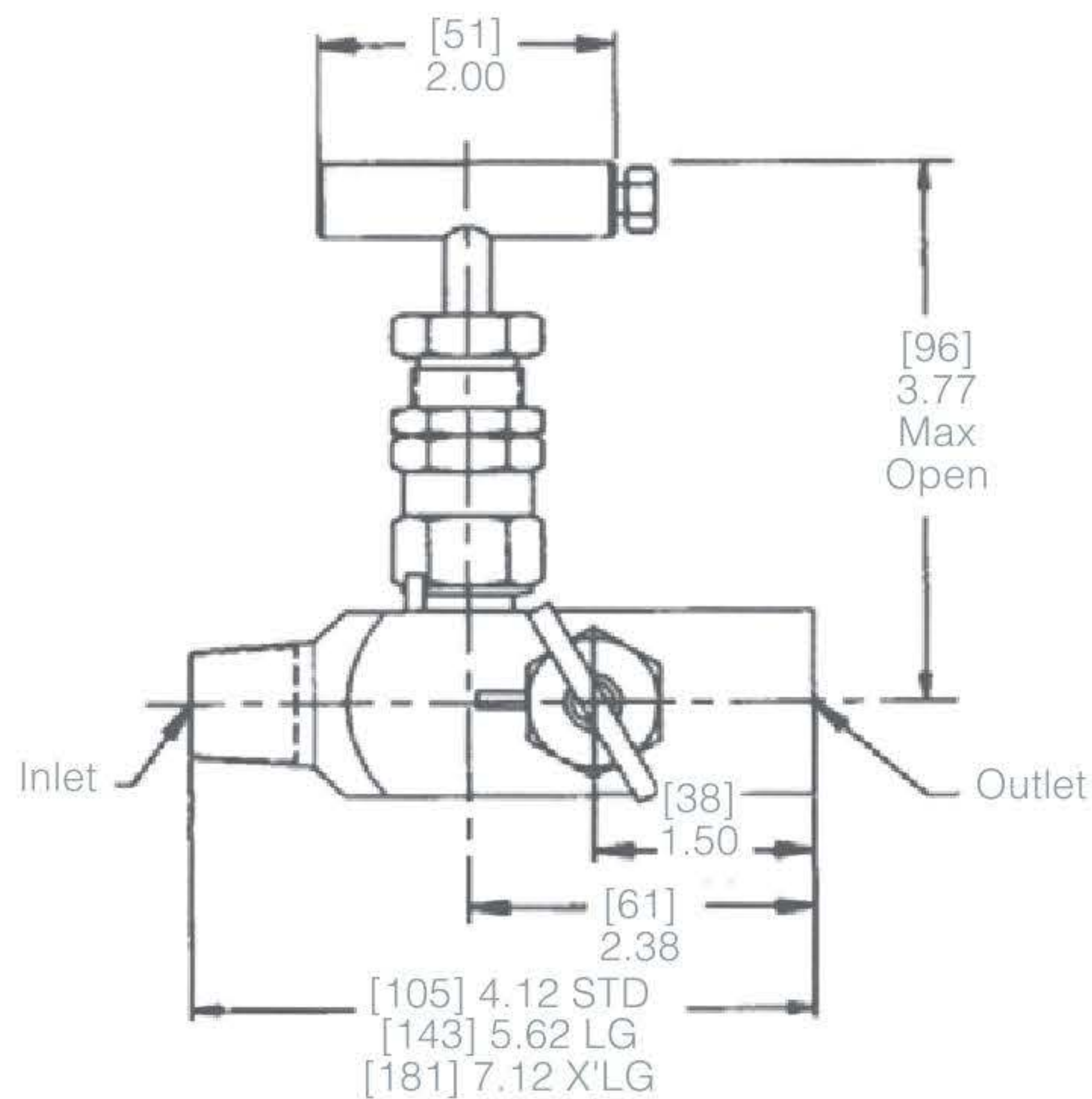
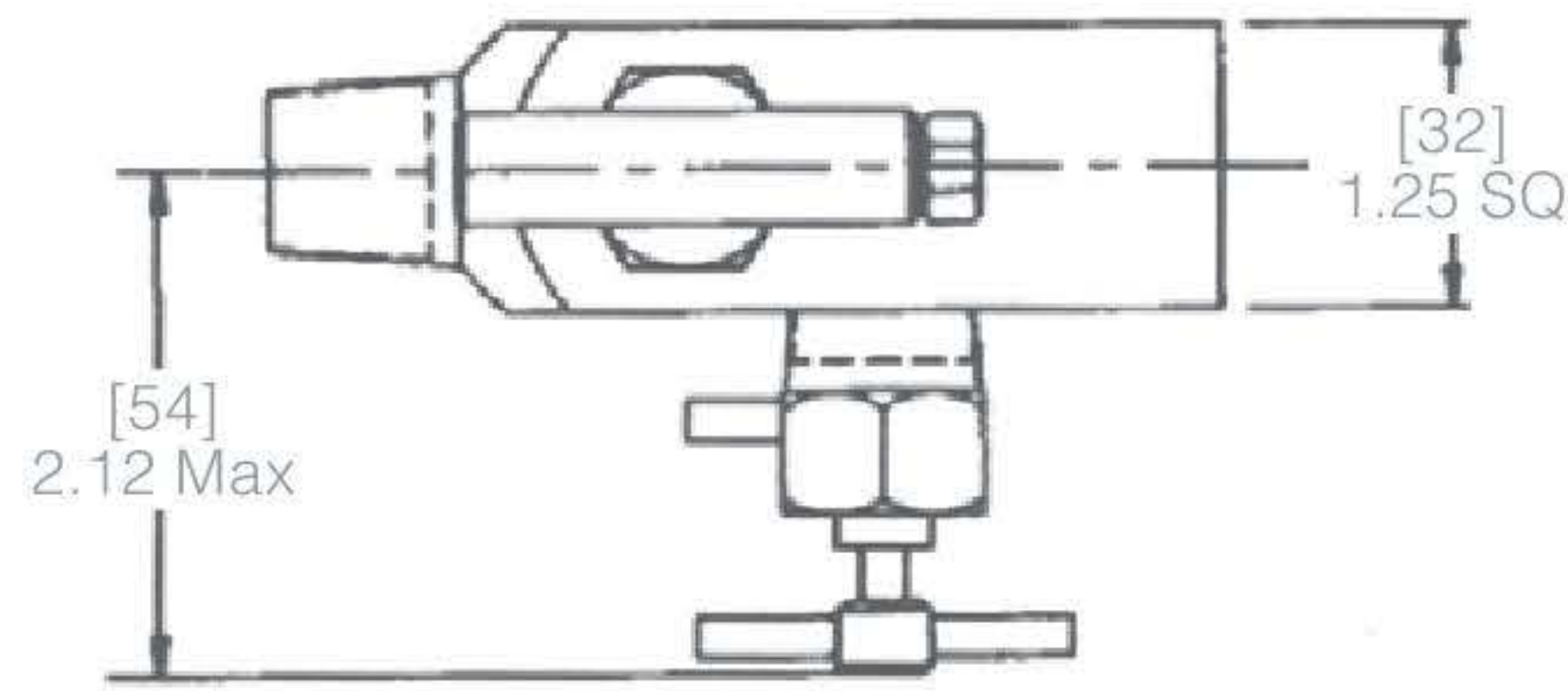

Flow Schematic

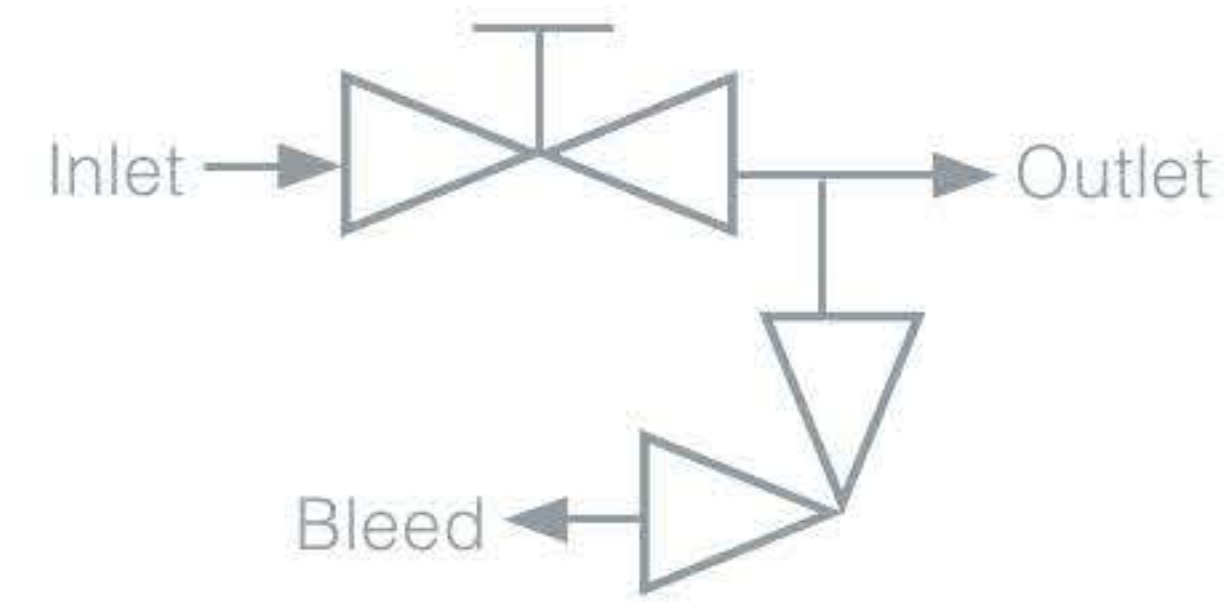

How to Order									
Model Number	Seat Configuration	Body Material	Inlet Size	Inlet Type	Outlet Size	Outlet Type	Stem / Tip	Seat Material	Packing
HB50	1 = Hard	S = Carbon Steel	3 = 1/2"	1 = MNPT	3 = 1/2"	1 = FNPT	2 = 316 SS Needle (soft seat)	1 = Integral	2 = TFE
HB51	2 = Soft Seat	U = Stainless Steel	4 = 3/4"	2 = MSW (HB50)			4 = 316 SS NRT	4 = PPS	3 = Graphite
	3 = Hard, "LG" Extension							5 = KEL-F	5 = Buna-N O-Ring (HB50)
	4 = Soft Seat, "LG" Extension							6 = TFE	6 = Viton O-Ring (HB50)
	5 = Hard, "XLG" Extension							9 = PEEK	
	6 = Soft Seat, "XLG" Extension								
	F = Hard / O-Ring								
	G = Soft / O-Ring								

Sample Ordering Schematic

HB50	1	S	4	2	3	1	2	1	1
------	---	---	---	---	---	---	---	---	---