

SELF-PRIMING FRAME MOUNTED PUMP

Series: BSP27MU

4" x 4"

Universal Drive

Spherical solids handling: 7/8"



SUCTION

4" NPT, female flange.

DISCHARGE

4" NPT, female.

LIQUID TEMPERATURE

Continuous: 160° F (71° C).

VOLUTE

Cast iron ASTM A-48, class 30.

BODY

Cast iron ASTM A-48, class 30.

PEDESTAL

Cast iron ASTM A-48, class 30.

IMPELLER

Design: 3 vanes, semi-open type, dynamically balanced.

Material: cast iron ASTM A-48, class 30.

SHAFT

Steel.

SHAFT SLEEVE

Steel.

HARDWARE

Steel.

O-RINGS

Buna-N.

PAINT

Air dry enamel, water based.

SEAL

Design: single mechanical with lip seal, water lubricated.

Material: ceramic stationary part, carbon ring seal and exclusion in the rotating part. Buna-N elastomer and stainless steel spring.

CHECKVALVE

Valve: flap-neoprene

Weight: steel.

BEARING-DRIVE END

Single row, ball, grease lubricated.

BEARING-PUMP END

Single row, ball, grease lubricated.

SHIM SET

Stainless steel.

STRAINER

Steel.

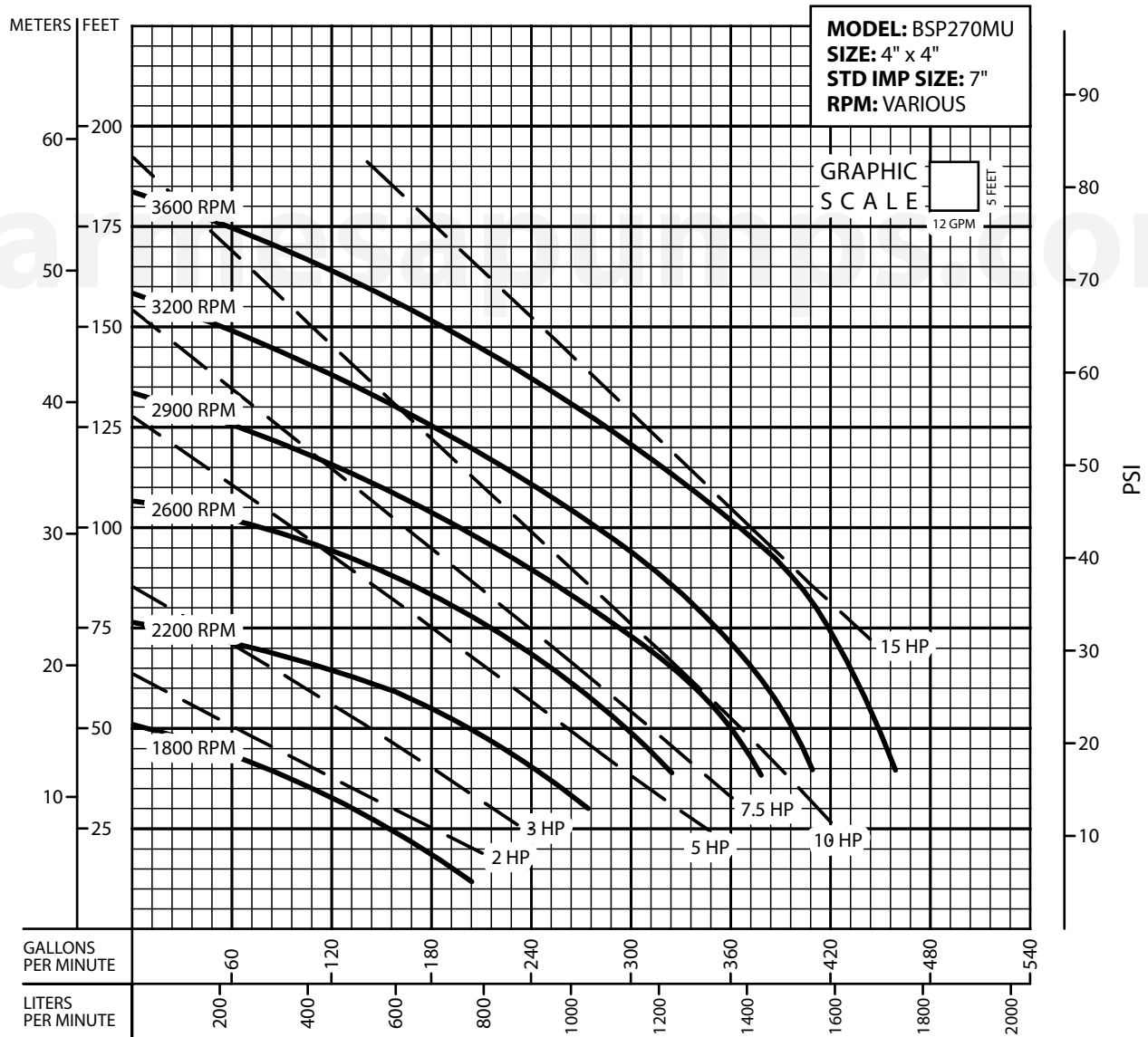
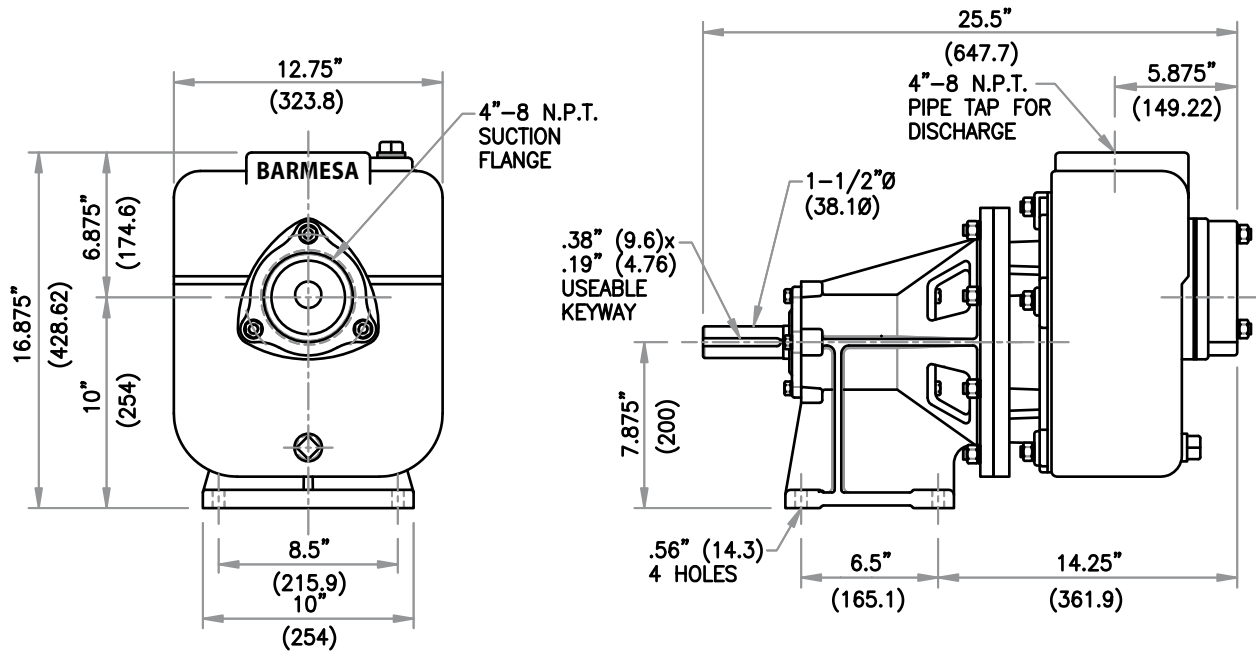

Testing is performed with water specific gravity of 1.0 @ 68° F (20° C); other fluids may vary performance.