

SLIDE RAIL COUPLING SRC-8

To be used with
8BSE series pumps.



LOCATION

This SRC-8 is designed for wet wells, tanks, or lift stations where it is necessary to remove a pump from service and reinstall the pump without maintenance personnel entering the pit to unbolt the pump flanges.

STATIONARY ELBOW

Cast iron ASTM A-48 class 30.

MOVABLE FITTING

Ductile iron ASTM A-536.

GUIDE RAIL CAP

Bracket: 304 stainless steel.

Plugs: rubber and steel.

HARDWARE

300 series stainless steel.

GASKETS

Rubber.

PAINT

Air dry enamel, water based.

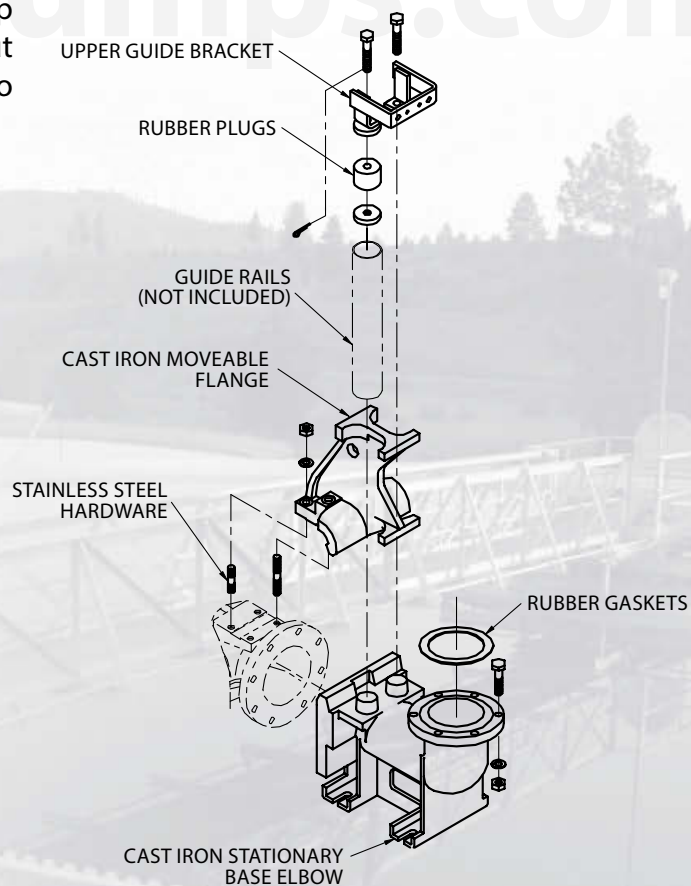

SLIDE RAIL COUPLING SRC-8

TO BE USED WITH 8SE SUBMERSIBLE PUMP
TYPICAL INSTALLATION
DIMENSIONS IN INCHES

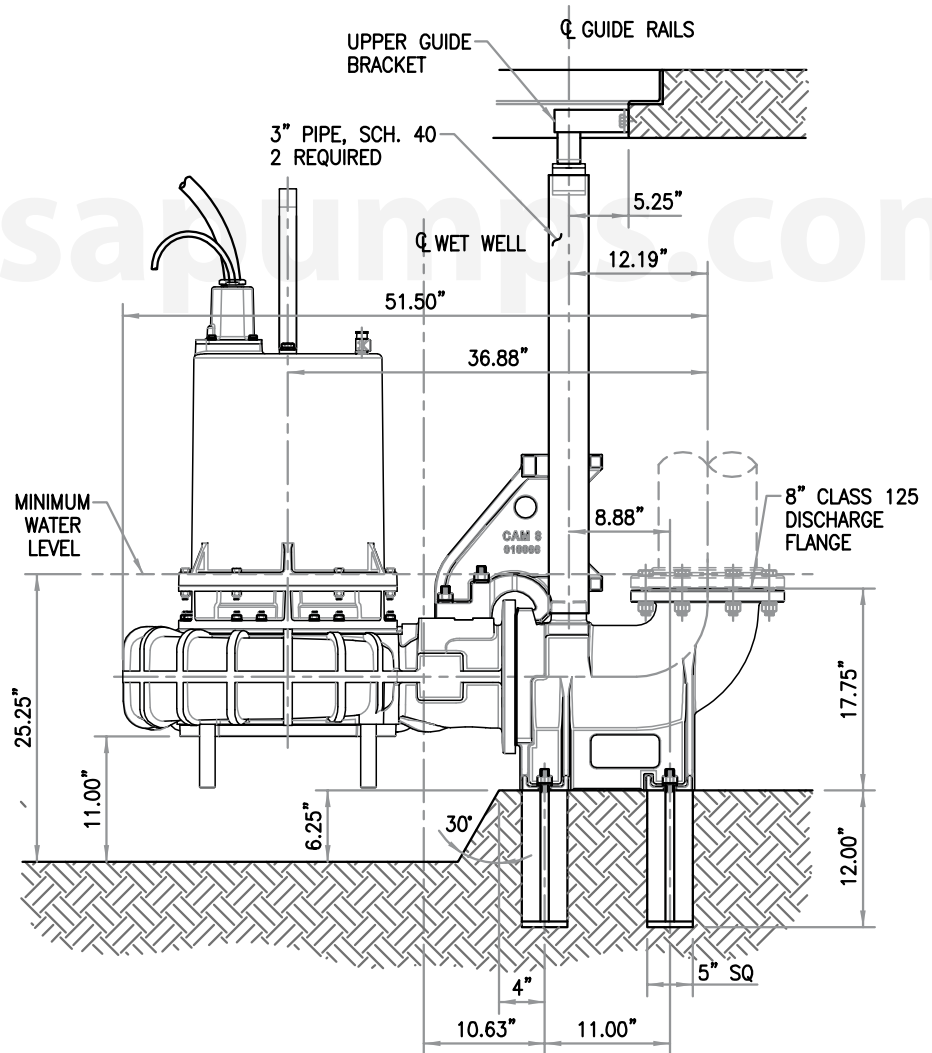
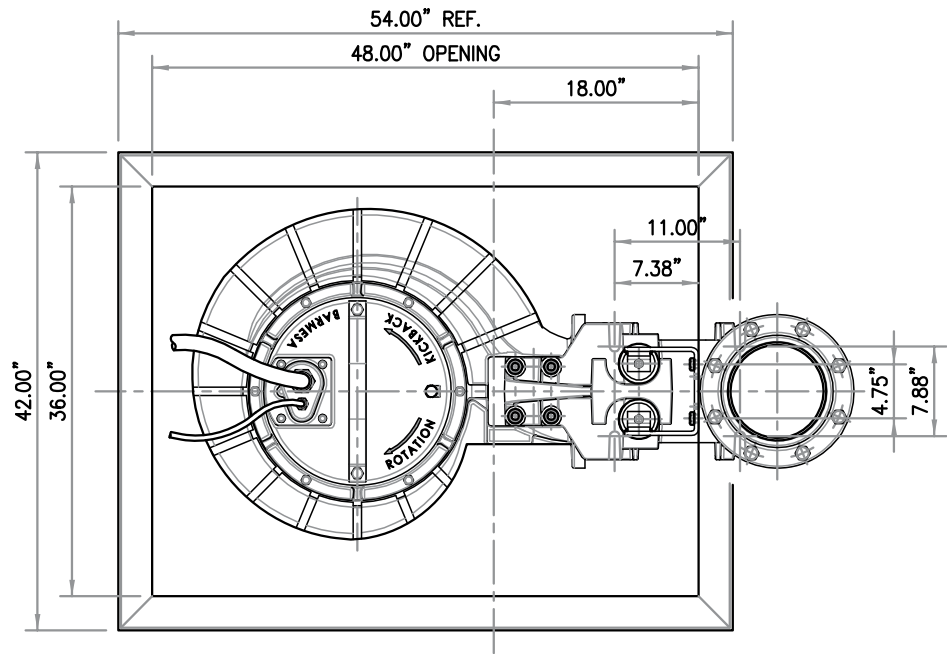

MODEL	PART No.	SIZE	RAILS	COUPLING	WEIGHT (pounds)
SRC8	-	8"	2"	w/ upper guide bracket	301