

SUBMERSIBLE NON-CLOG SEWAGE PUMP

Series: 4BSE-DS
4.5-15 HP / 1750 RPM
Discharge: 4"
Spherical solids handling: 3"



DISCHARGE

4", 125lb, flange horizontal.

LIQUID TEMPERATURE

104° F (40° C) continuous.

VOLUTE

Cast iron ASTM A-48 class 30.

MOTOR HOUSING

Cast iron ASTM A-48 class 30.

SEAL PLATE

Cast iron ASTM A-48 class 30.

IMPELLER

Design: 2 vane, open, with vanes on back side.

Material: cast iron ASTM A-48 class 30.

SHAFT

416 series stainless steel.

SQUARE RINGS

Buna-N.

PAINT

Air dry enamel, water based.

SEAL

Design: double, mechanical, oil filled chamber.

Material: silicon carbide outboard seal, carbon ceramic inboard seal, with stainless steel hardware.

DIAPHRAGM

Buna-N.

HARDWARE

300 series stainless steel.

CORD ENTRY

40 ft of cord, epoxy sealed housing with secondary pressure gromet for sealing and strain relief.

BEARINGS

Upper: ball, single row, oil lubricated, for radial load.

Lower: ball, single row, oil lubricated, for radial and thrust load.

MOTOR

Single phase: NEMA L, permanent split capacitor, 230 volts, 60 Hz, 1750 RPM, oil filled.

Three phase: NEMA B, 200/230 & 460 volts, 60 Hz, 1750 RPM, oil filled.

Requires overload protection to be included in control panel. Class F insulation.

MOISTURE SENSOR

Normally open (N/O) included, requires relay in control panel.

TEMPERATURE SENSOR

Normally closed (N/C) included, requires relay in control panel.

OPTIONAL EQUIPMENT

Additional cord, tungsten carbide seal, slide rail coupling (SRC-4).

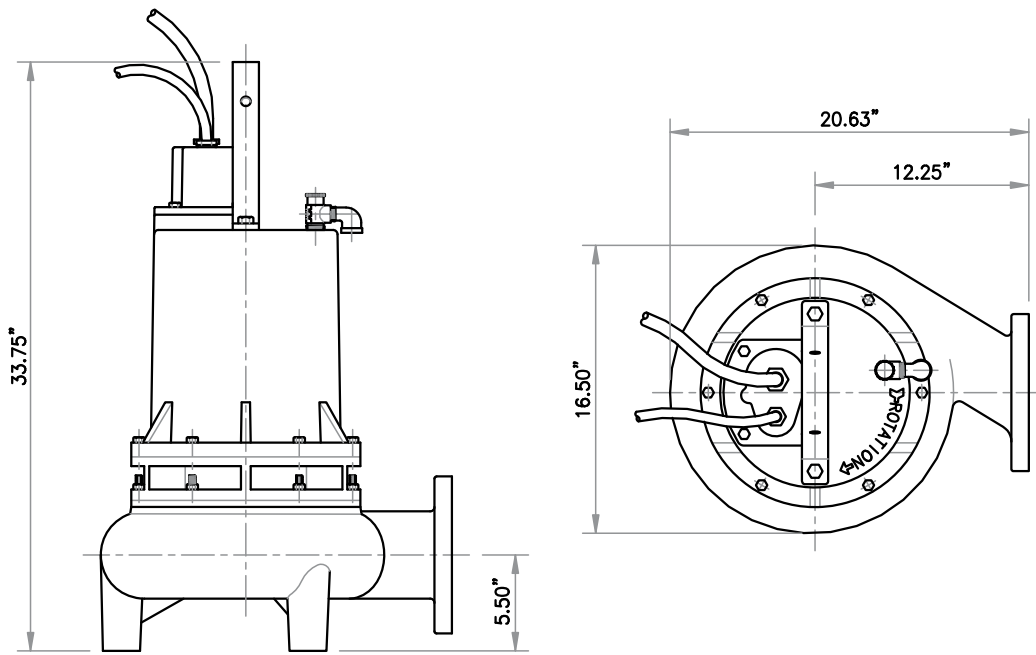

MODEL	PART No.	HP	VOLTS	PHASE	RPM (Nominal)	MAX AMPS	LOCKED ROTOR AMPS	NEMA CODE	CORD SIZE	CORD TYPE	CORD O. D.	WEIGHT (pounds)
4BSE452DS	62170121	4.5	230	1	1750	26	59	A	10/4	SO	0.78"	287
4BSE453DS	62170122	4.5	200/230	3	1750	17.6	56	E	10/4	SO	0.78"	280
4BSE454DS	62170123	4.5	460	3	1750	8.8	28	E	10/4	SO	0.78"	280
4BSE752DS	62170124	7.5	230	1	1750	39	96	A	10/4	SO	0.78"	315
4BSE753DS	62170125	7.5	200/230	3	1750	23.6	80	D	10/4	SO	0.78"	309
4BSE754DS	62170126	7.5	460	3	1750	11.8	40	D	10/4	SO	0.78"	309
4BSE1133DS	62170127	11.3	200/230	3	1750	28.4	126	D	10/4	SO	0.78"	340
4BSE1134DS	62170128	11.3	460	3	1750	14.2	63	D	10/4	SO	0.78"	340
4BSE1503DS	62170129	15	200/230	3	1750	40	160	D	10/4	SO	0.78"	399
4BSE1504DS	62170130	15	460	3	1750	20	80	D	10/4	SO	0.78"	399

The moisture cord and/or temperature cord is size 18/5, type SO, Ø0.485", for all models.

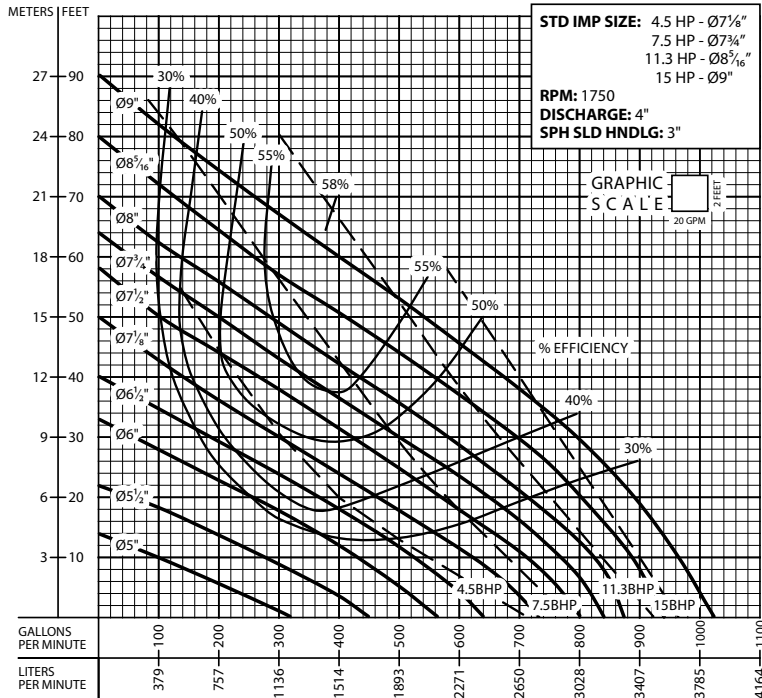

IMPORTANT!

1. Never use this pump to handle explosive liquids.
2. This pump is not approved to be used in swimming pools, recreational installations or any application where human contact may be common.
3. Pump may be operated "dry" for extended periods without damage to motor and/or seals.