

Series 25614

600# Flanged Cast Steel Check Valve



Valves, Automation & Controls

Features

- Bolted Cover
- Swing Type
- For Horizontal or Vertical lines
- Integral Seat
- Flanged Ends
- Butt-weld Ends
- Applicable Standards:
 - Steel valves ANSI B16.34
 - Face to face ANSI B16.10
 - End flanges ANSI B16.5
 - Butt-weld ends ANSI B16.25
 - Inspection and test API 598



Temperature °F	Working Pressure psi
-20 to 100	1480
200	1350
300	1315
400	1270
500	1200
600	1095
650	1075
700	1065
750	1010
800	825
850	535
900	345
950	205
1000	105

Dimensions, Parts & Materials

4" & Above

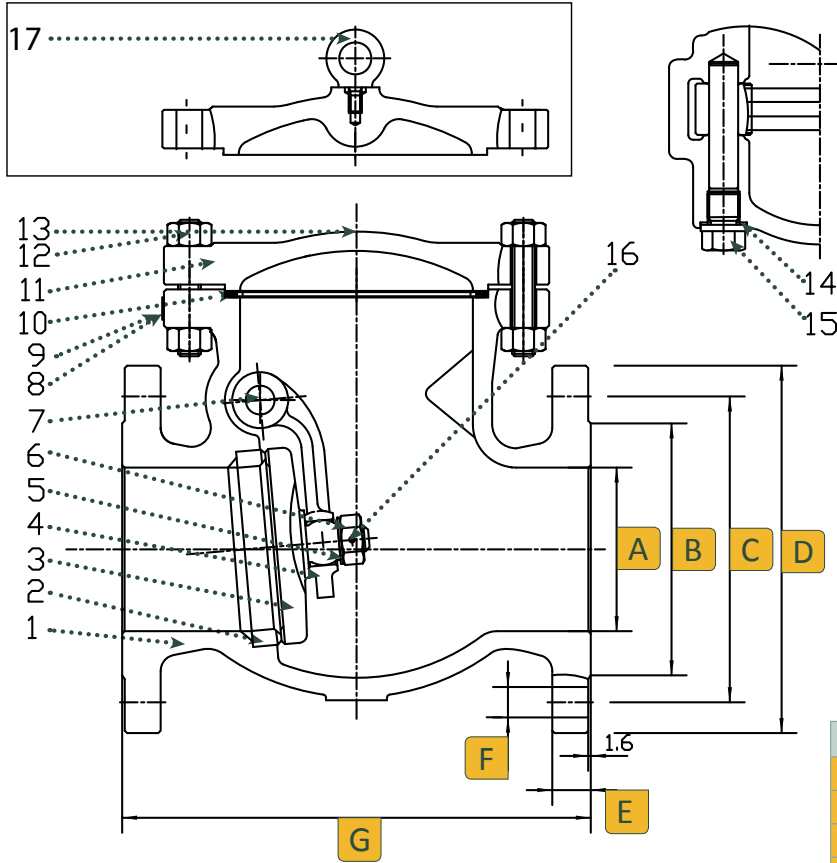

16" - 24"

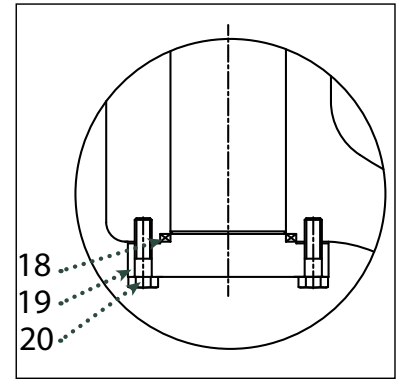

Size	A	B	C	D	E	F	G	Num of Bolt Holes
2	2.00	3.62	5.00	6.50	1.00	0.75	11.50	8
2-1/2	2.50	4.12	5.88	7.50	1.12	0.875	13.00	8
3	3.00	5.00	6.62	8.25	1.25	0.875	14.00	8
4	4.00	6.19	8.50	10.75	1.50	1.00	17.00	8
6	6.00	8.50	11.50	14.00	1.88	1.125	22.00	12
8	8.00	10.62	13.75	16.50	2.19	1.25	26.00	12
10	10.00	12.75	17.00	20.00	2.50	1.375	31.00	16
12	12.00	15.00	19.25	22.00	2.62	1.375	33.00	20
14	14.00	16.25	20.75	23.75	2.75	1.50	35.00	20
16	16.00	18.50	23.75	27.00	3.00	1.625	39.00	20
20	20.00	23.00	28.50	32.00	3.50	1.75	47.00	24
24	24.00	27.25	33.00	37.00	4.00	2.00	55.00	24

No.	Part Name	Material
1	Body	Carbon Steel A216 - WCB
2	Seat	A105 & STL6
3	Disc	A105 & 410 Stainless Steel
4	Hinge	Carbon Steel A216
5	Gasket	A276 410
6	Nut	A276 410
7	Pin	A276 410
8	Rivit	304 Stainless Steel
9	Name Plate	304 Stainless Steel
10	Gasket	F304 & Flexible Graphite
11	Cover	Carbon Steel A216 - WCB
12	Bolt	B7 Steel A193
13	Nut	2H Steel A194
14	Gasket	Soft Iron
15	Plug	410 Stainless Steel
16	Pin	304 Stainless Steel
17	Eyebolt	Carbon Steel
18	Gasket	F304 & Flexible Graphite
19	Bolt	Carbon Steel
20	Gland	Carbon Steel

Ordering

Fig: 8 - 25 - 6 - 1 - 4

Description: 8" - Series 25 - 600# Flange Ends - Cast Steel

Size	Series	Class	Ends	Body Material	Options
2	12	25	6	600	1 Flange
2-1/2	14				2 Butt-weld
3	16				
4	18				
6	20				
8	22				
10	24				
					4 Cast Steel
					X Oxygen Service
					SF Silicon Free
					RTJ Ring Type Joint Flange

Due to continuous development of our product range, we reserve the right to change the dimensions and information for this product as required.