

Series 30276

Gate Valve

Features

- 200 WOG @ 350 °F
- 316 stainless steel
- Screwed bonnet
- Solid wedge disc
- Non-rising stem
- Hydrostatic shell test at 300 psi
- Hydrostatic seat test at 220 psi
- Threaded or socket weld ends



Valves, Automation & Controls



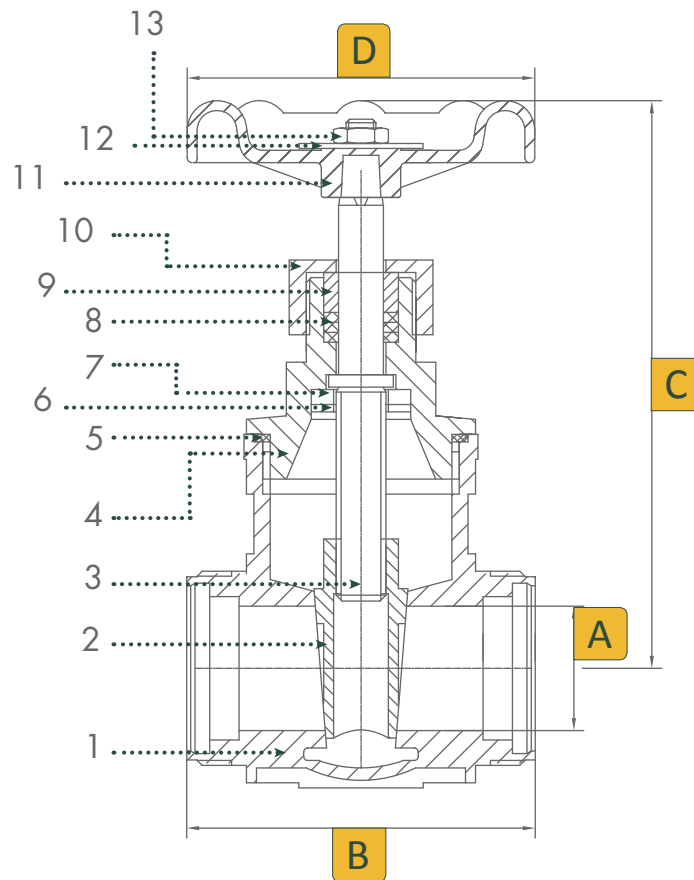

Dimensions (Inches)

| Size | A | B | C | D |
|-------|------|------|-------|------|
| 1/2 | 0.59 | 2.16 | 4.76 | 2.76 |
| 3/4 | 0.79 | 2.36 | 5.04 | 2.76 |
| 1 | 0.98 | 2.68 | 5.43 | 3.15 |
| 1-1/4 | 1.26 | 2.99 | 6.10 | 3.15 |
| 1-1/2 | 1.56 | 3.15 | 7.36 | 3.94 |
| 2 | 1.97 | 3.66 | 8.50 | 3.94 |
| 2-1/2 | 2.56 | 4.60 | 10.35 | 4.53 |
| 3 | 3.15 | 5.12 | 11.61 | 4.53 |

| No. | Part Name | Qty | Material |
|-----|---------------|-----|---------------------|
| 1 | Body | 1 | 316 Stainless Steel |
| 2 | Core | 1 | 316 Stainless Steel |
| 3 | Bonnet | 1 | 316 Stainless Steel |
| 4 | Packing | 1 | PTFE |
| 5 | Gland Nut | 1 | 304 Stainless Steel |
| 6 | Hand Wheel | 1 | Aluminum |
| 7 | Name Plate | 1 | Aluminum |
| 8 | Nut | 1 | 304 Stainless Steel |
| 9 | Stem | 1 | 316 Stainless Steel |
| 10 | Metal Padding | 1 | 304 Stainless Steel |
| 11 | Washer | 1 | 316 Stainless Steel |
| 12 | Seal | 1 | PTFE |

Ordering

Fig: 1 - 30276 - SW

Description: 1" - Stainless Steel Gate - Socket Weld

| Size | Series | Ends |
|-------|--------|----------------|
| 1/2 | 30276 | TE Threaded |
| 3/4 | | SW Socket Weld |
| 1 | | |
| 1-1/4 | | |
| 1-1/2 | | |
| 2 | | |
| 2-1/2 | | |
| 3 | | |

Due to continuous development of our product range, we reserve the right to change the dimensions and information for this product as required.