

# END-SUCTION CENTRIFUGAL PUMPS

Series: IC1¼

1 - 3 HP / 3500 RPM

Suction: 1½" NPT

Discharge: 1¼" NPT



## APPLICATIONS

- ▶ Booster systems
- ▶ Water transfer
- ▶ Chilled water system
- ▶ High flow-rate / medium pressure

## VOLUTE

Cast iron ASTM A-48 class 30.

## INTERMEDIATE COUPLING

Cast iron ASTM A-48 class 30.

## IMPELLER

**Design:** 5 vanes, closed, statically balanced.

**Material:** cast iron ASTM A-48 class 30.

## SEAL

**Design:** mechanical, type 01.

**Material:** Ceramic stationary part, carbon ring seal and exclusion in the rotating part. Buna-N elastomer and stainless steel spring.

## SHAFT SLEEVE

Stainless steel.

## O-RINGS

Buna-N.

## MOTOR

High quality premium efficiency TEFC or ODP electric motors, designed & developed in accordance with industry standards for industrial and commercial pumping applications.

- ▶ 1 & 3 phases, 60 Hz
- ▶ Rated output: 1 to 3 HP
- ▶ 3500 RPM

## HARDWARE

Carbon steel.

## PAINT

Air dry enamel, water based.

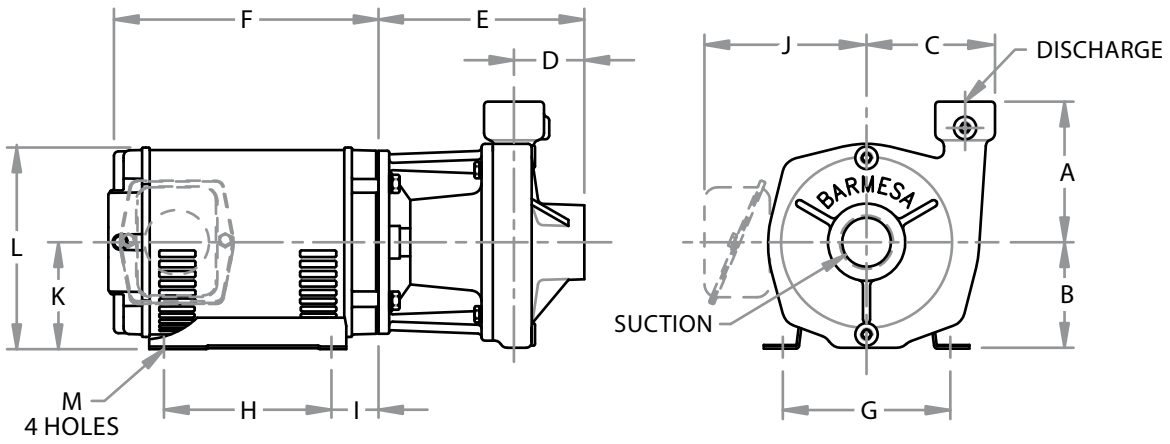

**ODP**

MODEL	PART No.	SIZE	HP	PHASE	RPM	FRAME	A	B	C	D	E	F	G	H	I	J	K	L	M	
IC1¼-1-2	62070501	1½" x 1¼"	1	3	3500	56 J	5	3.75	3.5	2.5	5.5	9.31	4.88	3	2.75	-	3.5	6.75	0.34	
IC1¼-1-2-1	62070502		1	1	3500	56 J						10.31								
IC1¼-1.5-2	62070503		1.5	3	3500	56 J						9.31								
IC1¼-1.5-2-1	62070504		1.5	1	3500	56 J						10.31								
IC1¼-2-2	62070505		2	3	3500	145 JM						7.31	12	5.5						5
IC1¼-2-2-1	62070506		2	1	3500	145 JM														
IC1¼-3-2	62070507		3	3	3500	182 JM														
IC1¼-3-2-1	62070508		3	1	3500	182 JM							11.81	7.5						4.5

All dimensions are in inches, and may vary depending on the motor manufacturer.

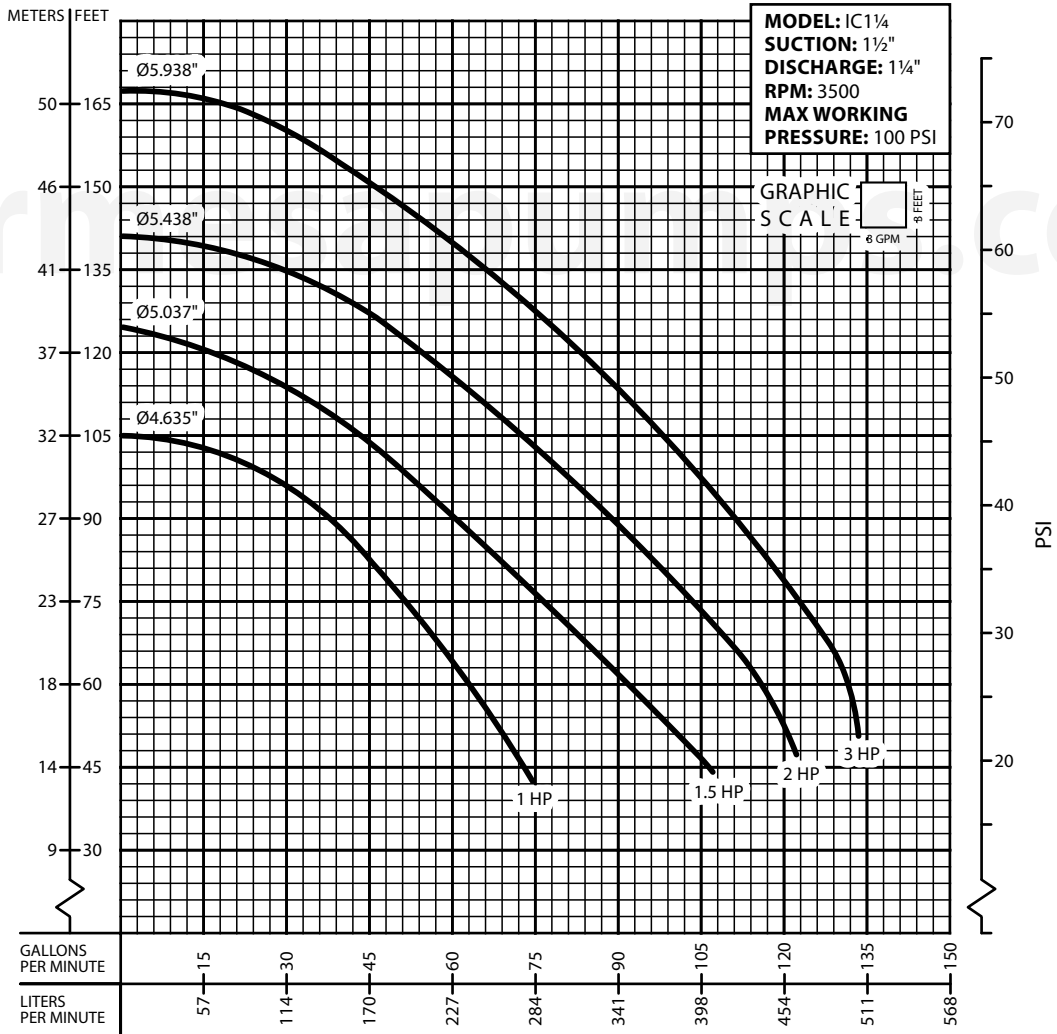

**IMPORTANT!**

1. Never use this pump to handle explosive liquids.
2. This pump is not approved to be used in swimming pools, recreational installations or any application where human contact may be common.
3. Testing is performed with water specific gravity of 1.0 @ 68° F (20° C); other fluids may vary performance.