

SEA Electric Actuator



Enclosure:

- IP 67: Waterproof and dust-proof enclosure
- NEMA 4X: Waterproof and dust-proof enclosure
- Material: Dry powder coating aluminum alloy

Motor:

- Standard extended duty cycle induction motor F insulation class for all models
- Built-in thermal protection (275°F) prevents motor burning out
- Standard Unit is 120 VAC
- Standard motors are 30% duty rated

Position Indicator:

- All models except SEA-1 have continuous mechanical position indicator on the top of the actuator cover

Manual Override:

- Non-clutch design, the manual operation can be operated without any lever, clutch or brake upon power outage
- When electric motor is operating, manual hand-wheel will not rotate for safety purposes

Gear Train:

- High alloy steel gear trains provide self-locking function to avoid valve back drive
- Gear trains have been already lubricated sufficiently with anti-high temperature lubricant at the factory

Working Conditions:

- Ambient temperature: -22°F to 149°F
- Humidity: 30% to 95%

Various Options:

- Space heater
- Additional limit switches (2 units)
- Potentiometer unit (1K Ohm or 5K Ohm)
- Local control unit (local/remote, on/off)
- Conduit entrance (1/2" PS, 3/4" PF, 1/2" NPT)
- Torque switches (2 units)
- Current position transmitter (output 4-20mA)
- Modulating controller (4-20mA, 1-5 VDC, 2-10 VDC)
- Various voltages
- Nylon enclosure material
- Thermostat
- 75% duty rating

Certifications:

- CE
- CSA (Conforming to the test standard for outdoor use)

SEA Electric Actuator Dimensions

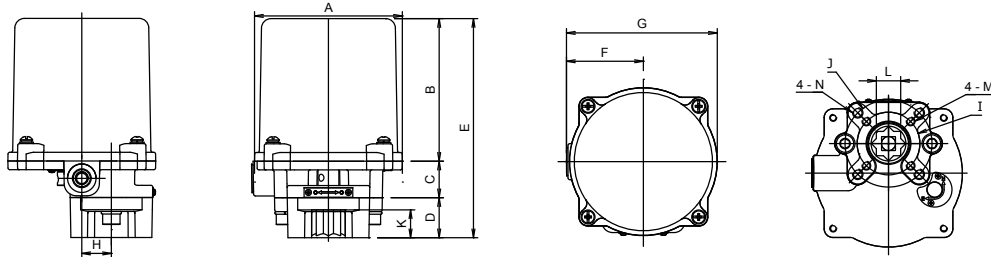

SEA 1

| Unit | A | B | C | D | E | F | G | H | I | J | K | L | M | N | Flange Type |
|------|------|------|------|------|------|------|------|------|------|------|------|------|--------|--------|-------------|
| in | 3.35 | 3.23 | 0.83 | 0.90 | 4.96 | 1.73 | 3.42 | 0.67 | 1.42 | 1.97 | 0.63 | 0.55 | M5x0.8 | M6x1.0 | F03 or F05 |
| mm | 85 | 82 | 21 | 23 | 126 | 44 | 87 | 17 | 36 | 50 | 16 | 14 | M5x0.8 | M6x1.0 | |

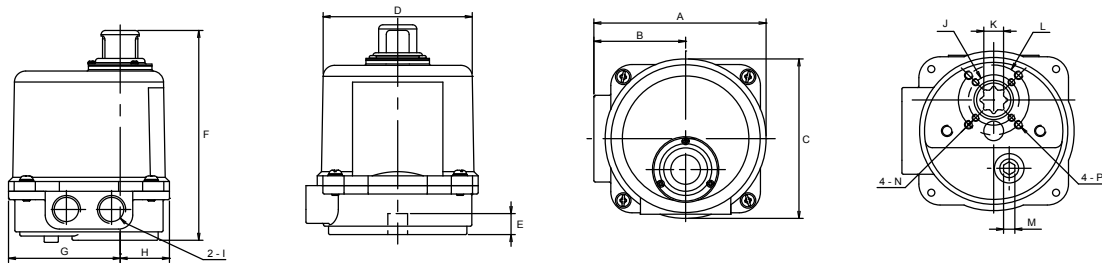

SEA 3

| Unit | A | B | C | D | E | F | G | H | I | J | K Max | L | M | N | P | Flange Type |
|------|------|------|------|------|------|-----|------|------|--------|------|-------|------|-----|--------|--------|-------------|
| in | 4.80 | 2.56 | 4.49 | 4.17 | 0.59 | 5.9 | 3.11 | 1.38 | 1/2 PS | 1.42 | 0.551 | 1.97 | 0.2 | M5x0.8 | M6x1.0 | F03 or F05 |
| mm | 122 | 65 | 114 | 106 | 15 | 150 | 79 | 35 | 1/2 PS | 36 | 14 | 50 | 8 | M5x0.8 | M6x1.0 | |

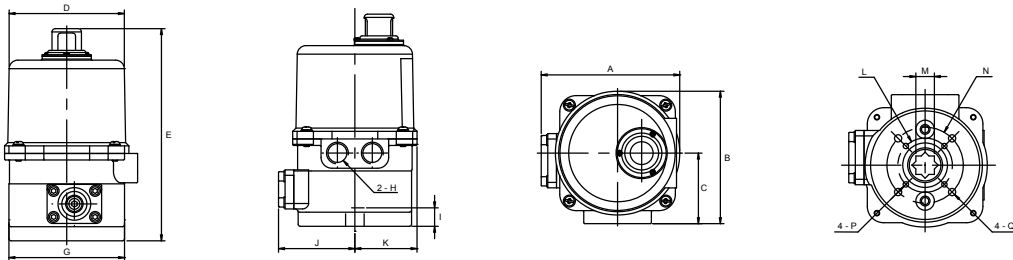

SEA 4

| Unit | A | B | C | D | E | G | H | I | J | K | L | M | N | P | Q | Flange Type |
|------|-----|-----|------|------|------|------|--------|------|------|------|------|-------|------|--------|---------|-------------|
| in | 5.0 | 4.8 | 2.56 | 4.02 | 7.71 | 4.17 | 1/2 PS | 0.79 | 2.76 | 2.24 | 1.97 | 0.669 | 2.76 | M6x1.0 | M8x1.25 | F05 or F07 |
| mm | 127 | 122 | 65 | 102 | 196 | 106 | 1/2 PS | 20 | 70 | 57 | 50 | 17 | 70 | M6x1.0 | M8x1.25 | |

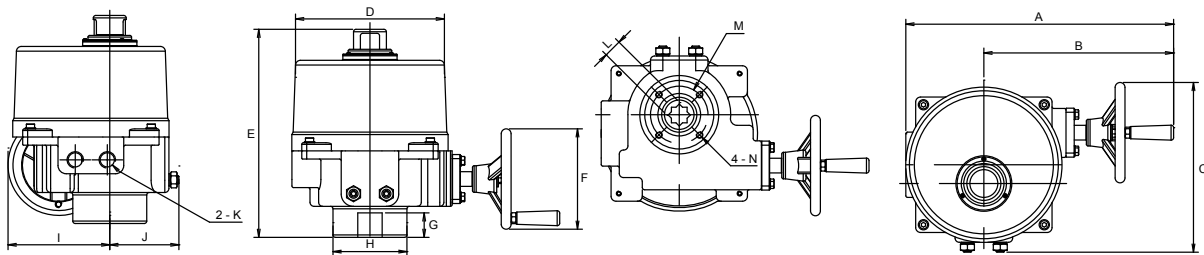

SEA 8 AND SEA 13

| Unit | A | B | C | D | E | F | G | H | I | J | K | L Max | M | N | Flange Type |
|------|-------|------|------|------|-------|------|------|------|------|------|--------|-------|------|---------|-------------|
| in | 12.83 | 9.09 | 8.15 | 7.13 | 10.04 | 4.76 | 1.18 | 3.54 | 4.88 | 3.31 | 1/2 PS | 0.867 | 2.76 | M8x1.25 | F07 |
| mm | 326 | 231 | 207 | 181 | 255 | 121 | 30 | 90 | 124 | 84 | 1/2 PS | 22 | 70 | M8x1.25 | |

SEA Electric Actuator Dimensions Cont.

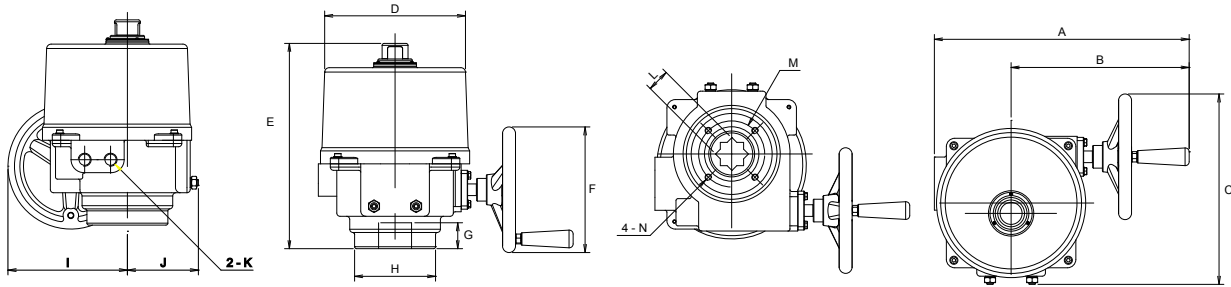

SEA 35, SEA 44 AND SEA 57

| Unit | A | B | C | D | E | F | G | H | I | J | K | L | M | N | Flange Type |
|------|-------|-------|-------|------|-------|------|------|------|------|------|--------|------|------|---------|-------------|
| in | 15.51 | 10.82 | 11.50 | 8.54 | 12.48 | 7.52 | 1.57 | 4.97 | 7.24 | 4.33 | 1/2 PS | 1.42 | 4.01 | M10*1.5 | F10 |
| mm | 394 | 275 | 292 | 217 | 317 | 191 | 40 | 125 | 184 | 110 | 1/2 PS | 36 | 102 | M10*1.5 | |

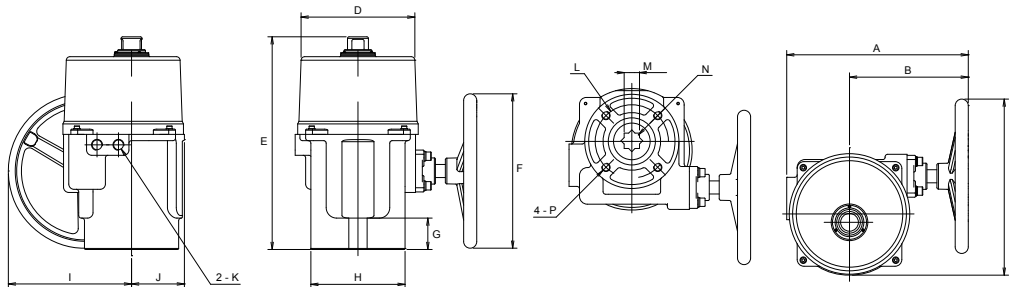

SEA 88 AND SEA 132

| Unit | A | B | C | D | E | F | G | H | I | J | K | L | M | N | P | Flange Type |
|------|-------|------|-------|------|-------|-------|------|------|------|------|--------|------|------|------|----------|-------------|
| in | 13.66 | 8.94 | 13.23 | 8.54 | 15.98 | 11.61 | 2.36 | 7.09 | 9.25 | 3.98 | 1/2 PS | 4.92 | 1.38 | 1.38 | M12*1.75 | F12 or F14 |
| mm | 347 | 227 | 336 | 217 | 406 | 295 | 60 | 180 | 235 | 101 | 1/2 PS | 125 | 35 | 35 | M12*1.75 | |

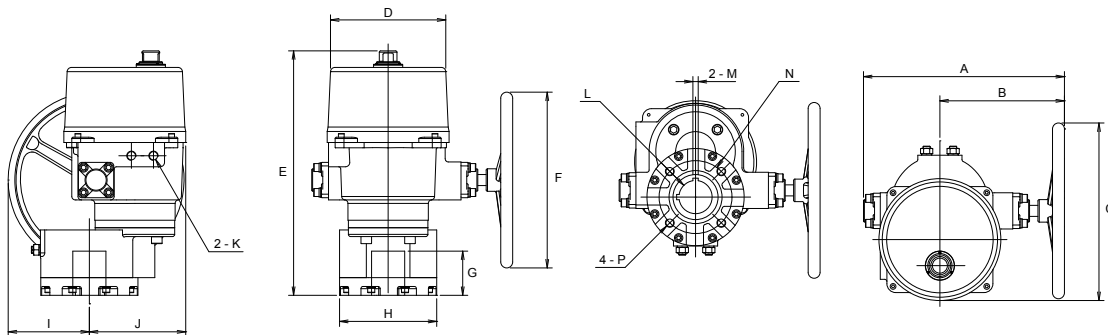

SEA 177, SEA 221, SEA 265 AND SEA 310

| Unit | A | B | C | D | E | F | G | H | I | J | K | L | M | N | P | Flange Type |
|------|-------|-------|-------|-------|-------|-------|------|------|------|------|--------|------|------|------|---------|-------------|
| in | 17.91 | 11.10 | 15.83 | 10.27 | 21.81 | 15.67 | 3.94 | 8.66 | 7.24 | 8.58 | 1/2 PS | 2.95 | 0.47 | 6.50 | M20*2.5 | F16 |
| mm | 455 | 282 | 402 | 261 | 554 | 398 | 100 | 220 | 184 | 218 | 1/2 PS | 75 | 12 | 165 | M20*2.5 | |

SEA Technical Information

| Model | Power (watts) | Max Torque (In/lb) | Speed (Sec/90°) | Weight (lb) | Manual Override | Mounting Flange |
|---------|---------------|--------------------|-----------------|-------------|-----------------|-----------------|
| SEA 1 | 5W | 132 | 19 | 3.3 | Lever | F03 / F05 |
| SEA 3 | 10W | 310 | 12 | 4.4 | Lever | F03 / F05 |
| SEA 4 | 10W | 443 | 20 | 6.6 | Lever | F05 / F07 |
| SEA 8 | 40W | 797 | 15 | 24.2 | Hand-wheel | F07 |
| SEA 13 | 40W | 1328 | 22 | 24.2 | Hand-wheel | F07 |
| SEA 35 | 80W | 3540 | 16 | 44 | Hand-wheel | F10 |
| SEA 44 | 80W | 4425 | 22 | 44 | Hand-wheel | F10 |
| SEA 57 | 80W | 5750 | 28 | 44 | Hand-wheel | F10 |
| SEA 88 | 120W | 8850 | 46 | 71 | Hand-wheel | F12 / F14 |
| SEA 132 | 120W | 13275 | 46 | 71 | Hand-wheel | F12 / F14 |
| SEA 177 | 180W | 17700 | 58 | 157 | Hand-wheel | F16 |
| SEA 221 | 180W | 22125 | 58 | 157 | Hand-wheel | F16 |
| SEA 265 | 180W | 26550 | 58 | 159 | Hand-wheel | F16 |
| SEA 310 | 220W | 31000 | 58 | 159 | Hand-wheel | F16 |

Fig: SEA3 - 2
Description: SEA3 - 24V

| How To Order | |
|--------------|-----------------------------|
| SEA Series | Options |
| SEA1 | 1 220V* |
| SEA3 | 2 24 VAC* |
| SEA4 | 3 12 VDC* |
| SEA8 | 4 24 VDC* |
| SEA13 | AS Auxiliary Switches |
| SEA 35 | FP Feedback Potentiometer* |
| SEA 44 | CR Control Relays* |
| SEA 57 | HT Heater & Thermostat |
| SEA 88 | PP Proportional Positioner* |
| SEA 132 | FT Feedback Transmitter* |
| SEA 177* | TR Timers* |
| SEA 221* | TS Torque Sensor* |
| SEA 265* | *POA |
| SEA 310* | |

SEA Spring Return Electric Actuator



- Spring return models are designed to provide a fail-safe position in the event of a power loss of supply voltage a mechanical spring set is utilized to position the valve or damper to either the fully open or fully closed position without any external power source.
- A mechanical buffer system is employed at the end of the spring stroke to reduce the dynamic effect of the springs returning to the fail safe position.
- Standard unit fails clockwise, counter-clockwise rotation failure is available.
- A clutch-less, lever-less manual over-ride provides full-time manual capabilities.
- Patented in Taiwan, USA, Japan and China
- 50% duty rated
- Temperature range: -22° F TO +149° F with use of heater and thermostat
- Powder coated aluminum alloy enclosure
- Nema 4X, IP67
- Gear train comes lubricated for life from factory
- Visual indicator
- Voltage options include: 24VAC, 24VDC, 10/220V 1 phase, 220/380/440V 3 phase

| Model | Power (watts) | Max Torque (In/lb) | Motor Speed (Sec/90°) | Speed Spring | Mounting Flange |
|---------------|-----------------------|--------------------|-----------------------|--------------|-----------------|
| SEA-4-SR-MO* | 1.5A RUN / 2.8A LOCK | 440 | 7-9 SECONDS | 3 SECONDS | F07 |
| SEA-11-SR-MO* | 3.8A RUN / 11A LOCK | 1150 | 7-9 SECONDS | 8 SECONDS | F10 |
| SEA-17-SR-MO* | 3.8A RUN / 11.5A LOCK | 1770 | 11-13 SECONDS | 12 SECONDS | F12 |
| SEA-23-SR-MO* | 3.8A RUN / 11.5A LOCK | 2300 | 14-17 SECONDS | 12 SECONDS | F12 |

*POA

SEA Spring Return Electric Actuator Dimensions

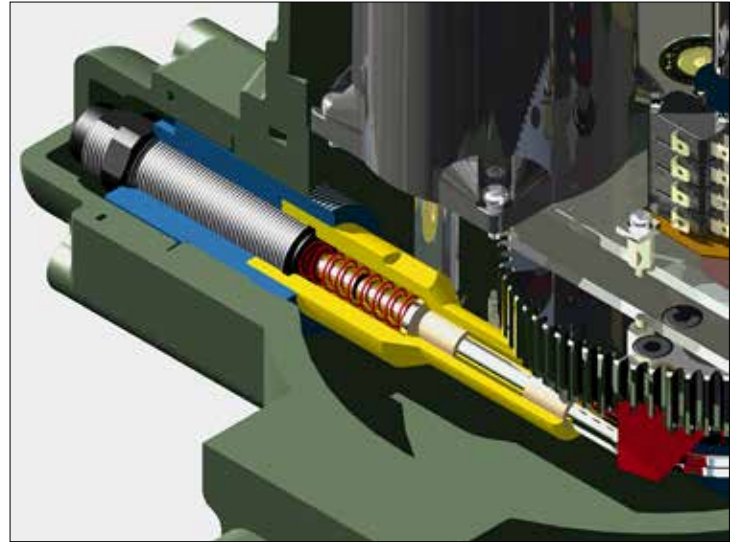
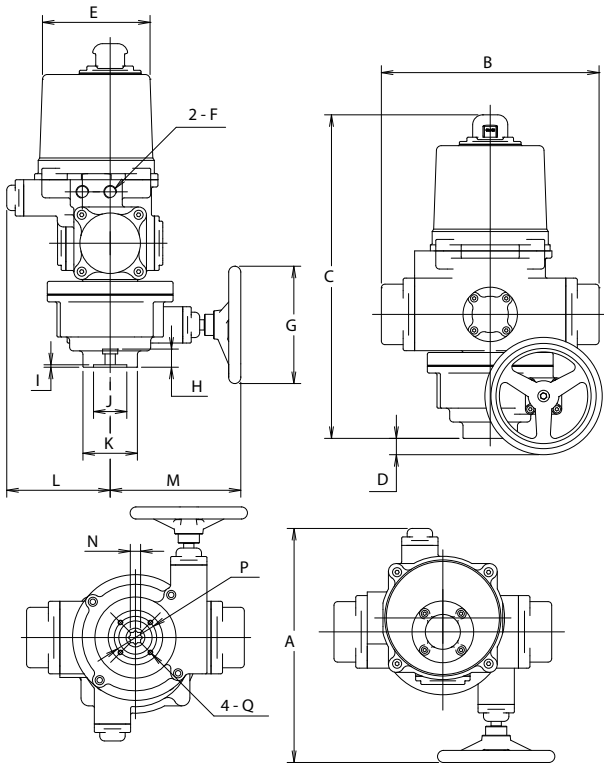

SPRING BUFFER SYSTEM

| Model | Unit | A | B | C | D | E | F | G | H | I | J | K | L | M | N | P | Q | Flange Type |
|--------------|----------|--------------|--------------|--------------|-------------|--------------|-------------|--------------|------------|-----------|------------|-------------|--------------|--------------|------------|-------------|---------------|-------------|
| SEA-4-SR-MO | in mm | 15.09 387 | 14.04 360 | 20.87 535 | 1.38 35 | 6.94 178 | 1/2" NPT | 7.57 194 | 1.17 30 | 0.16 4 | 2.15 55 | 3.51 90 | 6.67 171 | 8.42 216 | 0.66 17 | 2.73 70 | M8 x 1.25 | F07 |
| SEA-11-SR-MO | in mm | 18.84 483 | 18.02 462 | 25.12 638 | 2.70 68 | 10.43 265 | 1/2" NPT | 11.61 295 | 1.61 41 | 0.20 5 | 2.73 70 | 4.88 125 | 9.33 237 | 9.20 236 | 0.86 22 | 3.98 102 | M10 x 1.5 | F10 |
| SEA-17-SR-MO | in mm | 22.97 589 | 23.40 600 | 28.50 732 | 4.30 109 | 12.00 305 | 1/2" NPT | 15.70 398 | 1.76 45 | 0.20 5 | 3.32 85 | 5.85 150 | 11.90 305 | 11.08 284 | 1.05 27 | 4.88 125 | M12 x 1.75 | F12 |
| SEA-23-SR-MO | in mm | 22.97 589 | 23.40 600 | 28.50 732 | 4.30 109 | 12.00 305 | 1/2" NPT | 15.70 398 | 1.76 45 | 0.20 5 | 3.32 85 | 5.85 150 | 11.90 305 | 11.08 284 | 1.05 27 | 4.88 125 | M12 x 1.75 | F12 |