

Series 76

3-way Ball Valve



Valves, Automation & Controls

Features

- 4- Seat Design
- Blow-out proof and live loaded stem packing
- Many choices of body and ball porting configurations are available to suit piping system requirements.
- Locking devices
- ISO 5211 Mounting Pad



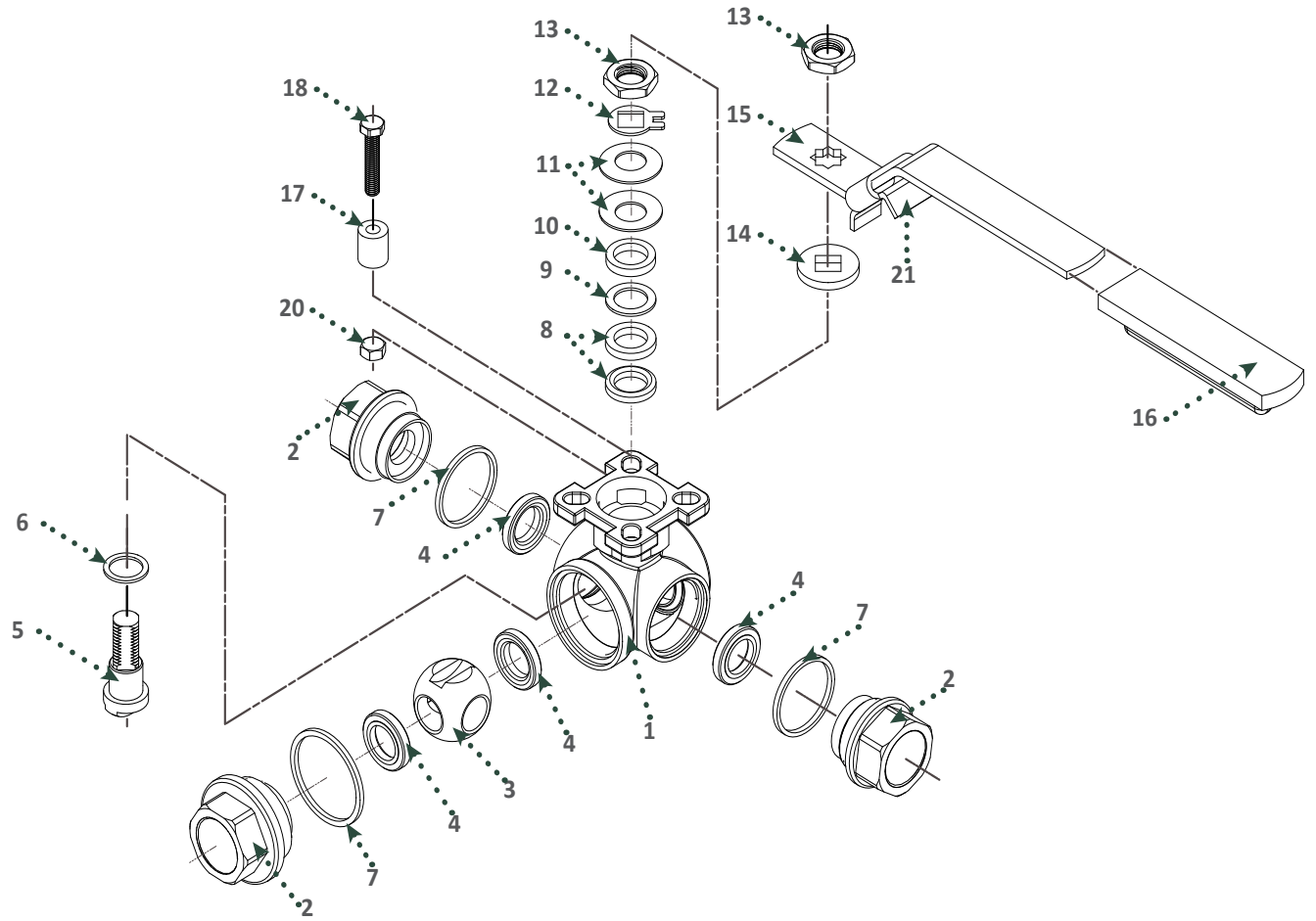

No.	Part Name	Qty	Material
1	Body	1	316 Stainless Steel ASTM A351 CF8M
2	Ends	3	316 Stainless Steel ASTM A351 CF8M
3	Ball	1	316 Stainless Steel ASTM A351 CF8M
4	Seat	4	RTFE
5	Body Seal	3	PTFE
6	Stem	1	316 Stainless Steel
7	Thrust Washer	1	PTFE
8	O-Ring	1	Viton
9	Stem Packing	2	PTFE
10	Gland Packing	1	304 Stainless Steel
11	Belleville Washer	1	301 Stainless Steel
12	Stem Nut	1	304 Stainless Steel
13	Lock Tab	1	304 Stainless Steel
14	Washer	1	304 Stainless Steel
14A	Handle Nut	1	304 Stainless Steel
15	Handle	1	304 Stainless Steel
16	Locking Device	1	304 Stainless Steel
17	Handle Sleeve	1	Vinyl
18	Stopper	1	304 Stainless Steel
18A	Stopper Sleeve	1	304 Stainless Steel
18B	Stopper Nut	1	304 Stainless Steel

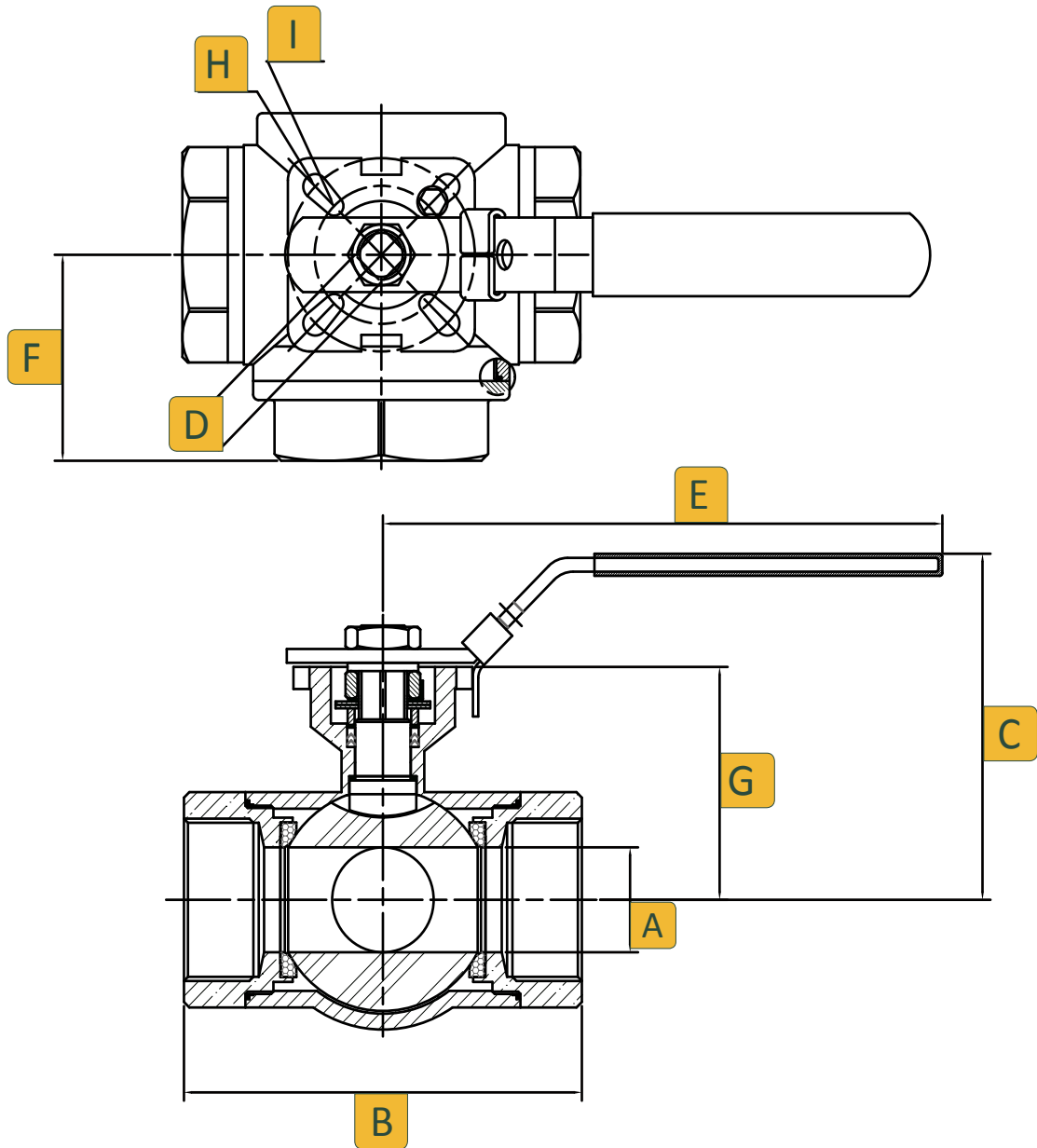

Dimensions (Inches)

Size	A	B	C	D	E	F	G	I	H	J
1/4	0.43	2.98	3.05	0.35	4.41	1.47	1.60	0.24	0.24	0.32
3/8	0.43	2.98	3.05	0.35	4.41	1.47	1.60	0.24	0.24	0.32
1/2	0.50	2.98	3.05	0.35	4.41	1.47	1.60	0.24	0.24	0.32
3/4	0.63	3.41	3.23	0.35	4.41	1.76	1.78	0.24	0.28	0.35
1	0.79	4.03	3.69	0.43	5.37	2.02	2.22	0.24	0.28	0.51
1-1/4	0.98	4.65	3.98	0.43	7.40	2.27	2.44	0.28	0.36	0.51
1-1/2	1.26	4.95	4.73	0.55	7.78	2.47	2.89	0.28	0.36	0.65
2	1.50	5.87	5.11	0.55	7.78	2.94	3.44	0.36	0.45	0.65

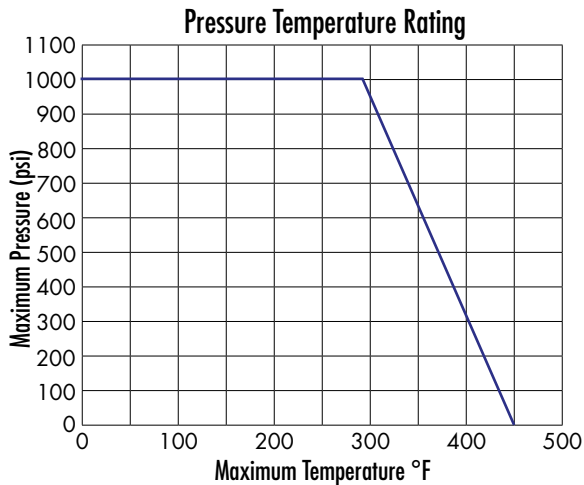

Size	CV T Port	CV L Port	Torque Kg/cm	Torque/Lbs	Weight Lbs
1/4	6	5	40	35	1.65
3/8	6	5	40	35	1.65
1/2	12	11	50	43	1.65
3/4	16	14	65	56	2.40
1	20	18	115	100	3.70
1-1/4	46	43	210	182	5.40
1-1/2	88	84	260	226	8.00
2	98	90	430	373	12.80

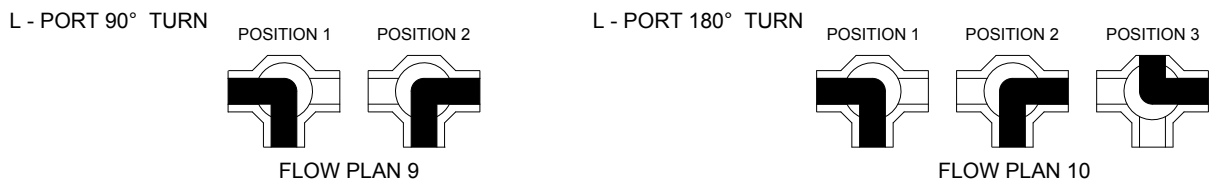
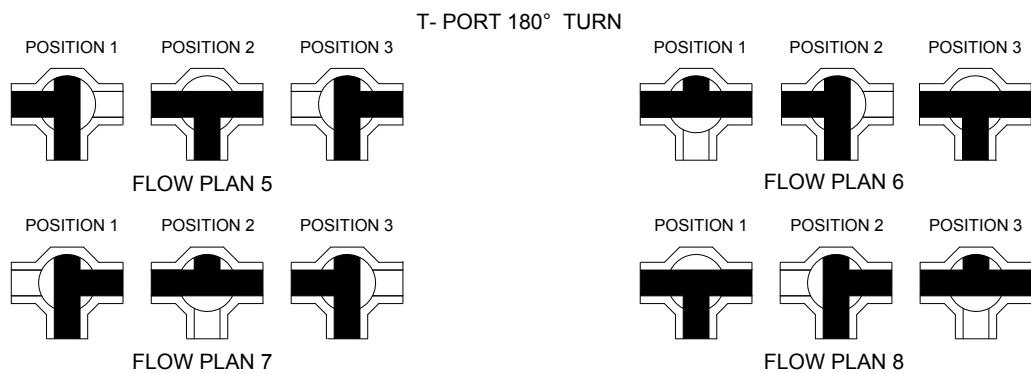
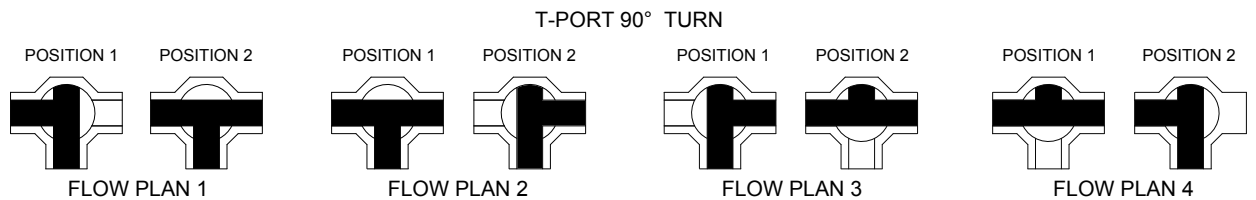

Ordering

Fig: 1/2 - 76 - 6 - 6 - M - 3 - OH

Description: 1/2" - Series 76 - 316 Body - 316 Ball & Stem, TFM Seat, Flow Plan 3

Size	Series	Body	Ball and Stem	Seat	Flow Plan	Options
1/4	76	6 316 Stainless Steel	6 316 Stainless Steel	M TFM	1	SW Socket Weld
3/8					2	GO Gear Operator
1/2					3	OH Oval Handle
3/4					4	
1					5	
1-1/4					6	
1-1/2					7	
2					8	
					9	
					10	

Due to continuous development of our product range, we reserve the right to change the dimensions and information for this product as required.