

SUBMERSIBLE NON-CLOG SEWAGE PUMP

Series: 6BSE-LDS
9-30 HP / 1150 RPM
Discharge: 6"
Spherical solids handling: 4"



DISCHARGE

6", 125 lb, flange horizontal.

LIQUID TEMPERATURE

104° F (40° C) continuous.

VOLUTE

Cast iron ASTM A-48 class 30.

WEAR RING

Bronze.

MOTOR HOUSING

Cast iron ASTM A-48 class 30.

SEAL PLATE

Cast iron ASTM A-48 class 30.

IMPELLER

Design: 1 vane, closed, with vanes on back side.

Material: cast iron ASTM A-48 class 30.

SHAFT

416 class stainless steel.

SQUARE RINGS

Buna-N.

PAINT

Air dry enamel, water based.

DIAPHRAGM

Buna-N.

HARDWARE

300 series stainless steel.

SEAL

Design: double, mechanical, oil filled chamber.

Material: silicon carbide outboard seal, carbon ceramic inboard seal, with stainless steel hardware.

CORD ENTRY

25 ft of neoprene cord 2/4 G, sealed against moisture.

BEARINGS

Upper: ball, single row, oil lubricated, for radial load.

Lower: ball, single row, oil lubricated, for radial and thrust load.

MOTOR

NEMA B, three phase, 208/230 & 460 volts, 60 Hz, 1150 RPM, oil filled. Requires overload protection to be included in control panel.

MOISTURE SENSOR

Normally open (N/O) included.

TEMPERATURE SENSOR

Normally closed (N/C) included.

OPTIONAL EQUIPMENT

Impeller trimming, additional cord, tungsten carbide seal, slide rail coupling (SRC-6).

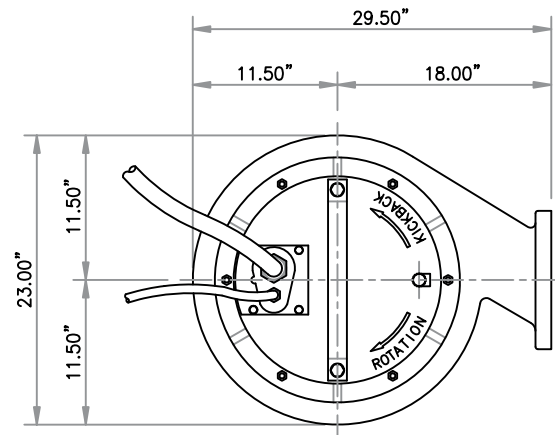
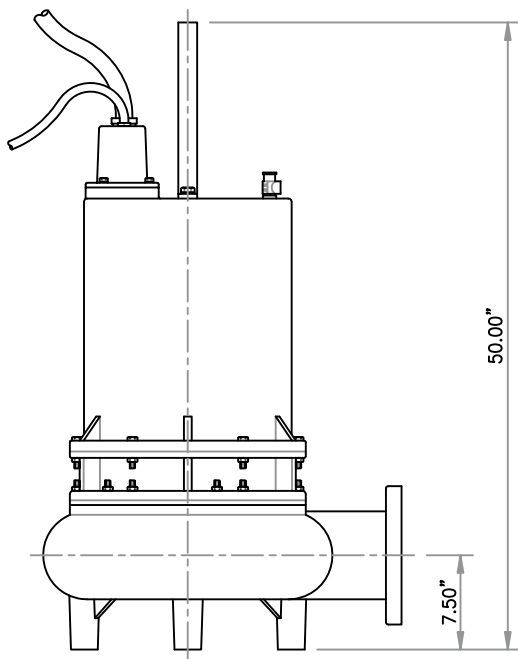

MODEL	PART No.	HP	VOLTS	PHASE	RPM (Nominal)	MAX AMPS	LOCKED ROTOR AMPS	NEMA CODE	CORD SIZE	CORD TYPE	CORD O. D.	WEIGHT (pounds)
6BSE9036LDS	62170271	9	208/230	3	1150	26	162	F	2/3	G	1.34"	897
6BSE9046LDS	62170272	9	460	3	1150	13	81	J	2/3	G	1.34"	897
6BSE12036LDS	62170273	12	208/230	3	1150	36	162	D	2/3	G	1.34"	902
6BSE12046LDS	62170274	12	460	3	1150	18	81	F	2/3	G	1.34"	902
6BSE18036LDS	62170275	18	208/230	3	1150	50	232	C	2/3	G	1.34"	917
6BSE18046LDS	62170276	18	460	3	1150	25	116	F	2/3	G	1.34"	917
6BSE24036LDS	62170277	24	208/230	3	1150	64	290	C	2/3	G	1.34"	961
6BSE24046LDS	62170278	24	460	3	1150	32	145	E	2/3	G	1.34"	961
6BSE30036LDS	62170279	30	208/230	3	1150	82	364	C	2/3	G	1.34"	1008
6BSE30046LDS	62170280	30	460	3	1150	41	182	E	2/3	G	1.34"	1008

The moisture cord and/or temperature cord is size 18/5, type SO, Ø0.485", for all models.

IMPORTANT!

1. Never use this pump to handle explosive liquids.
2. This pump is not approved to be used in swimming pools, recreational installations or any application where human contact may be common.
3. Pump may be operated "dry" for extended periods without damage to motor and/or seals.



PERFORMANCE CURVE

Submersible Non-Clog Sewage Pump

Models: 6BSE-LDS

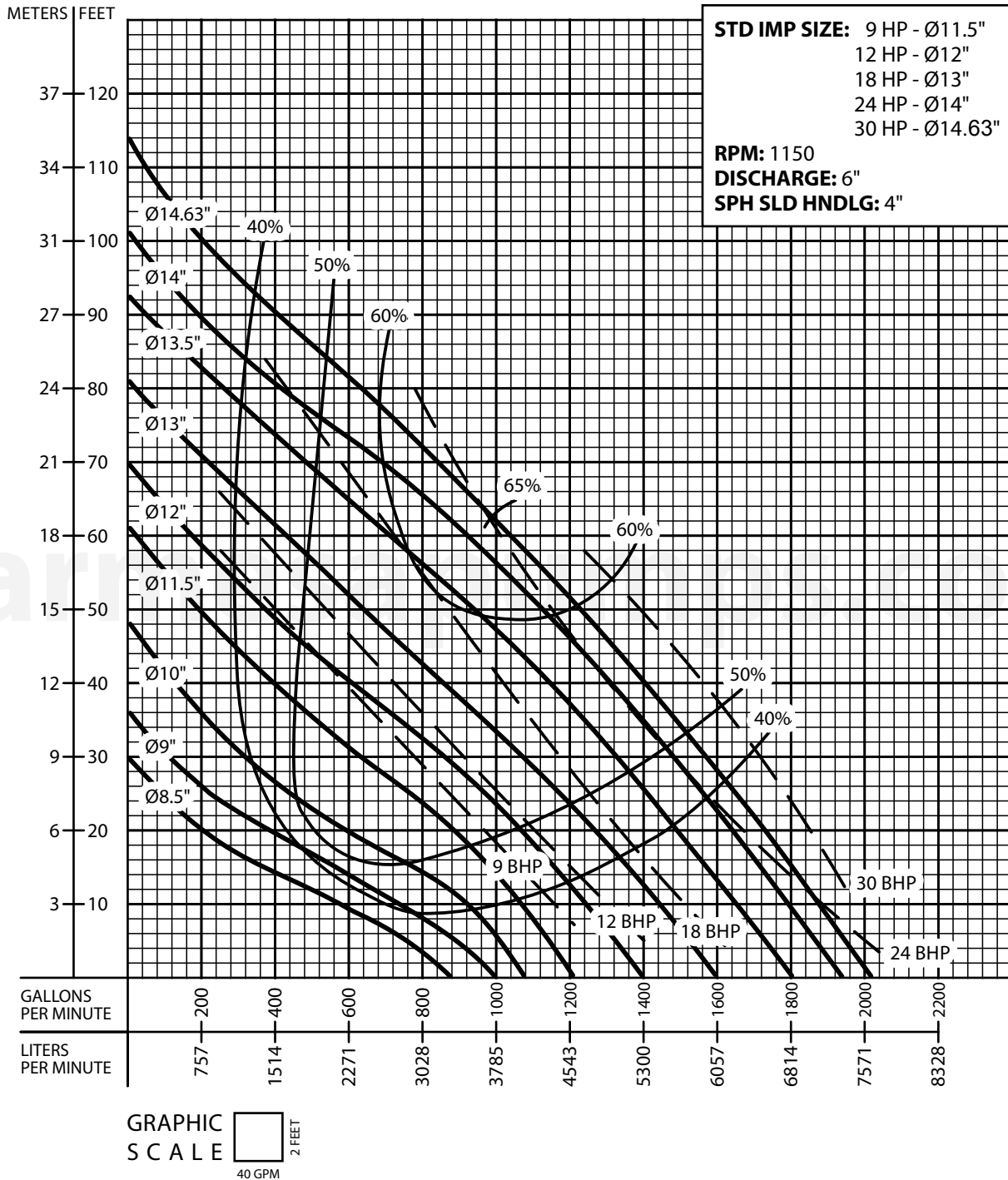

Testing is performed with water specific gravity of 1.0 @ 68° F (20° C); other fluids may vary performance.