

QLT M10

It's more than a light tower.
It's Predictable Light.



Atlas Copco



QLT M10

BRIGHT AND DEPENDABLE LIGHT

Looking for reliability in portable lighting? The Atlas Copco QLT M10 delivers the light you need, no matter the conditions. With high luminosity and light coverage and powerful reliability, the QLT M10 helps you get your job done.

SAFE AND QUICK INSTALLATION

SIMPLE INSTALLATION





Quickly install the QLT M10 and get on with your work. The QLT M10's mast can be extended to its maximum height of 31ft (9.5m) in seconds and rotated 360° to find the **perfect lighting angle**. No need to constantly move the tower.

STABLE IN ALL CONDITIONS

Two outriggers and four leveling jacks ensure the stability of the QLT M10, even on uneven work sites.

COMPACT SIZE

The QLT M10 is extremely **light and maneuverable**. Up to 12 units can be transported on a flatbed truck.

Performance	
Service efficiency	
Resale value	
Safety	
Ease of use	

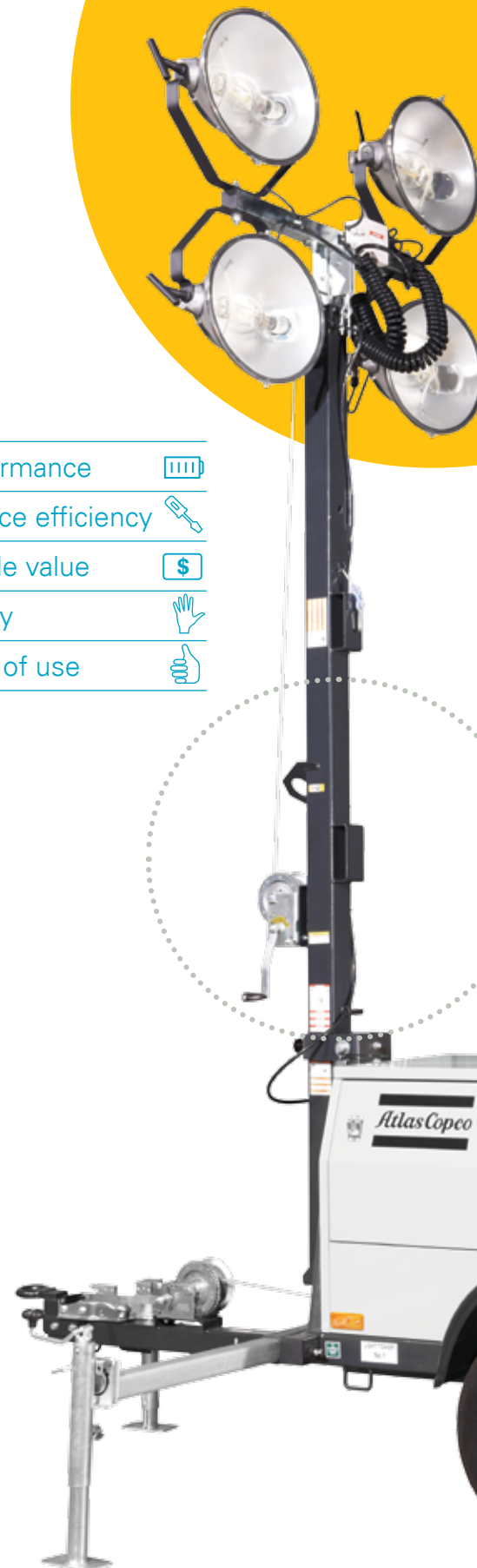

UNIFORM
LIGHT

EASY TO USE



BUILT
TOUGH

EASY OPERATION

LONG REFUELING INTERVALS

The QLT M10's 30 gallon fuel tank ensures **60-70 hours of run time** (depending on environmental conditions) before refueling. The translucent polyethylene tank provides an instant view of the fuel level, so there's no need for a separate gauge.

EASE OF USE

The easy-to-use **control panel** features a running hour meter, sockets for powering external equipment and circuit breakers for on/off functionality and protection.

COLD WEATHER STARTING

The fuel-efficient diesel engine includes a glow plug preheating system for cold weather starting.

SUPREME RELIABILITY

EFFICIENT, BRIGHT LIGHT

The **metal halide lamp technology** is one of the most efficient ways of turning electrical energy into light. It requires less power and produces more light, increasing productivity while saving time and money.

STRAIGHTFORWARD MAINTENANCE

The exclusive hinged top panel provides **easy access** to the engine, generator and electrical components for quick and hassle-free maintenance.

ROBUST CONSTRUCTION

The QLT M10 is protected from the elements with a **lockable, weather-resistant steel canopy**. All components have been selected for durability and shock resistance.

ENGINE PROTECTION

An **automatic engine shutdown system** protects the engine from damage due to low oil pressure and high coolant temperature.

Atlas Copco

TECHNICAL DATA

Performance data		QLT M10
Rated frequency	Hz	60
Rated voltage	V	120
Rated power (PRP)	kW	6
Operating temperature (min./max.)	°F (°C)	14/122 (-10/50)
Sound pressure level @ 7m (LPA)	dB(A)	71

Engine - Kubota		
Model		D1005-E3BG EPA Tier 4
Speed	rpm	1800
Rated net output (PRP)	kW	8.7kW
Coolant		Liquid cooled diesel
Number of cylinders		3

Alternator - Mecc Alte		
Model		LT3-100/4
Rated output	kVA	6
Insulation (stator & rotor)/enclosure protection	class/IP	H/21

Consumption		
Fuel tank capacity	gallon	30
Fuel consumption	gph	1.67 (l/h)/4kW
Runtime before refueling		60 to 70 hours, approx. .44@4kW load
Battery		65 Ah, 570 CCA

Power output		
Aux power MCCB	W	2200

Lights		
Lamps		Four metal halide
Wattage	W	4 x 1000
Luminosity		0.5 fc @ 7.5 acres (5.4 lm/m ² @ 30,400 m ²)
Luminous flux	lumen	440,000 (4 x 110,000)

Manual mast		
Rotation	degrees	360
Maximum height	ft	31
Maximum speed wind	mph	65

Construction		
Trailer		MIG welded, unibody-style, four point leveling system
Finish		Oven-baked powder coated
Tow hitch		2 inch ball/pintle combo
Tires		155R13

Dimensions and weight		
Dimensions in transport (LxWxH)	inches	182 x 48 x 66
Dimensions in operation (LxWxH)	inches	132 x 2.64 x 150/372
Weight	lbs	1800



5 KEY BENEFITS

- High luminosity
- Supreme reliability
- Service efficiency
- Transport/storage efficiency
- Resale value/long lifetime

MAIN FEATURES

- Bright metal halide lamps
- Robust mast, frame and body
- Long autonomy fuel tank
- Accessible
- User-friendly controls

GENUINE ATLAS COPCO PARTS

Genuine Atlas Copco parts ensure the QLT M10's proper operation and long lifetime:

- Service kits
- Fluids
- Individual engine, alternator and mast parts

Check with your local Atlas Copco Service Provider for more information on Genuine Atlas Copco parts and on standard and extended warranty conditions.

Atlas Copco Construction Equipment

Mining, Rock Excavation and Construction LLC
 3700 East 68th Avenue
 Commerce City, CO 80022
 Tel. 800-732-6762
 Fax. 303-288-8828
www.atlascopco.us