

- **Built-in Automatic Check Valve**
- **Reduced Cavitation Design**
- **Service Without Removal From Line**
- **Packless Construction**
- **Drip-Tight, Positive Seating**



The Cla-Val Model 100-31 Powercheck Valve is a hydraulically operated diaphragm valve with a built-in check feature to prevent return flow. Available in globe or angle pattern, it consists of four major components: the body, intermediate chamber, diaphragm assembly and cover. The diaphragm assembly is the only moving part.

The diaphragm assembly which is guided top, center and bottom by a precision machined stem utilizes a non-wicking diaphragm of nylon fabric bonded with synthetic rubber. A synthetic rubber disc retained on three and one-half sides forms a drip-tight seal with the renewable seat when pressure is applied above the diaphragm. When pressure above the diaphragm is relieved, the valve opens wide. The rate of closing or opening can be controlled by modulating the flow into or out of the cover chamber. When a pressure reversal occurs the valve will immediately close, preventing reverse flow through the valve. The split stem will allow the disc retainer assembly to check closed **regardless of the position of the diaphragm.**

The Model 100-31 Powercheck Valve is recommended on system applications where a positive check feature is necessary to prevent reverse flow.

Principle of Operation

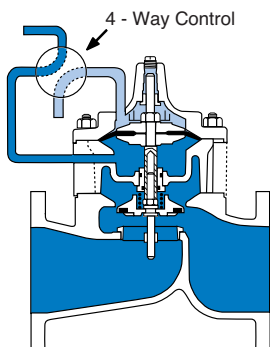

Full Open Operation

When operating pressure below the diaphragm is greater than the pressure in the cover chamber, the valve is held open, allowing full flow.

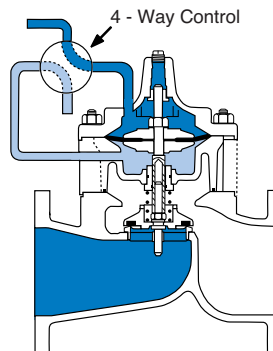

Tight Closing Operation

When pressure below the diaphragm is relieved and operating pressure is applied to the cover chamber, the valve closes drip-tight.

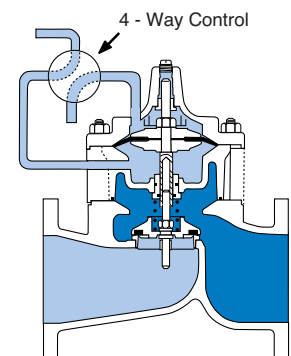

Check Action

When a static condition or pressure reversal occurs, the split stem design allows the valve to instantly check closed. Return flow is prevented regardless of the diaphragm's position.

Available Sizes

Pattern	Flanged
Globe	4" - 6" - 8" - 10"
Angle	4" - 6 - 8"

Operating Temp. Range

Fluids
-40° to 180° F

Pressure Ratings (Recommended Maximum Pressure - psi)

Valve Body & Cover		Pressure Class		
		Flanged		
Grade	Material	ANSI Standards*	150 Class	300 Class
ASTM A536	Ductile Iron	B16.42	250	400
ASTM A216-WCB	Cast Steel	B16.5	285	400
ASTM B62	Bronze	B16.24	225	400

Note: * ANSI standards are for flange dimensions only.
 Flanged valves are available faced but not drilled.
Valves for higher pressure are available; consult factory for details



4" Globe, Flanged



6" Globe, Flanged

Materials

Component	Standard Material Combinations		
Body & Cover	Ductile Iron	Cast Steel	Bronze
Available Sizes	4" - 10"	4" - 10"	4" - 10"
Disc Retainer & Diaphragm Washer	Cast Iron	Cast Steel	Bronze
Trim: Disc Guide, Seat & Cover Bearing	Bronze is Standard Stainless Steel is optional		
Disc	Buna-N® Rubber		
Diaphragm	Nylon Reinforced Buna-N® Rubber		
Stem, Nut & Spring	Stainless Steel		

For material options on sizes not listed, consult factory.
 Cla-Val manufactures valves in more than 50 different alloys.

Options

Epoxy Coating - suffix KC

This option NSF 61 Listed and FDA approved, fusion bonded epoxy coating is for use with cast iron, ductile iron or steel valves. This coating is resistant to various water conditions, certain acids, chemicals, solvents and alkalies. Epoxy coatings are applied in accordance with AWWA coating specifications C116-03. Do not use with temperatures above 175° F.

Viton® Rubber Parts - suffix KB

Optional diaphragm, disc and o-ring fabricated with Viton® synthetic rubber. Viton® is well suited for use with mineral acids, salt solutions, chlorinated hydrocarbons, and petroleum oils; and is primarily used in high temperature applications up to 250° F. Do not use with epoxy coating above 175°F.

For assistance in selecting appropriate valve options or valves manufactured with special design requirements, please contact our Regional Sales Office or Factory.



6" Angle, Flanged

Valve Size		Inches	4	6	8	10
		mm.	100	150	200	250
C _V Factor	Globe Pattern	Gal./Min. (gpm.)	136	229	480	930
		Litres/Sec. (l/s.)	32.5	55	115	223
	Angle Pattern	Gal./Min. (gpm.)	135	233	545	—
		Litres/Sec. (l/s.)	32	56	132	—
Equivalent Length of Pipe	Globe Pattern	Feet (ft.)	251	777	748	621
		Meters (m.)	76.4	237.1	228.1	189.5
	Angle Pattern	Feet (ft.)	254	751	580	—
		Meters (m.)	77.6	229	176.9	—
K Factor	Globe Pattern		12.7	23.1	15.7	10.4
	Angle Pattern		12.9	22.3	12.2	—
Liquid Displaced from Cover Chamber When Valve Opens		Fl. Oz	—	—	—	—
		U.S. Gal.	.08	.17	.53	1.26
		ml	—	—	—	—
		Litres	.30	.64	2.0	4.8

Application Note

The distinctive smooth flow path of the 600 series Powercheck valve is engineered to overcome cavitation problems. It's unique design is highly resistant to cavitation damage under severe pressure drops. Tests have proven it to be effective in preventing valve body and seat pitting.

We also offer a free computerized cavitation analysis. This analysis provides cavitation damage information for actual conditions provided by the customer. If there is an application where the potential for cavitation exists, the 600 series Powercheck valve provides substantial resistance to this problem.

C_V Factor

Formulas for computing C_V Factor, Flow (Q) and Pressure Drop (ΔP):

$$C_V = \frac{Q}{\sqrt{\Delta P}} \quad Q = C_V \sqrt{\Delta P} \quad \Delta P = \left(\frac{Q}{C_V} \right)^2$$

K Factor (Resistance Coefficient)

The Value of K is calculated from the formula: $K = \frac{894d^4}{C_V^2}$ (U.S. system units)

Equivalent Length of Pipe

Equivalent lengths of pipe (L) are determined from the formula: $L = \frac{Kd}{12f}$ (U.S. system units)

Fluid Velocity

Fluid velocity can be calculated from the following formula: $V = \frac{.4085 Q}{d^2}$ (U.S. system units)

Where:

C_V = U.S. (gpm) @ 1 psi differential at 60° F water or

= (l/s) @ 1 bar (14.5 PSIG) differential at 15° C water

d = inside pipe diameter of Schedule 40 Steel Pipe (inches)

f = friction factor for clean, new Schedule 40 pipe (dimensionless) (from Cameron Hydraulic Data, 18th Edition, P 3-119)

K = Resistance Coefficient (calculated)

L = Equivalent Length of Pipe (feet)

Q = Flow Rate in U.S. (gpm) or (l/s)

V = Fluid Velocity (feet per second) or (meters per second)

ΔP = Pressure Drop in (psi) or (bar)

Model 100-31 Flow Chart (Based on normal flow through a wide open valve)

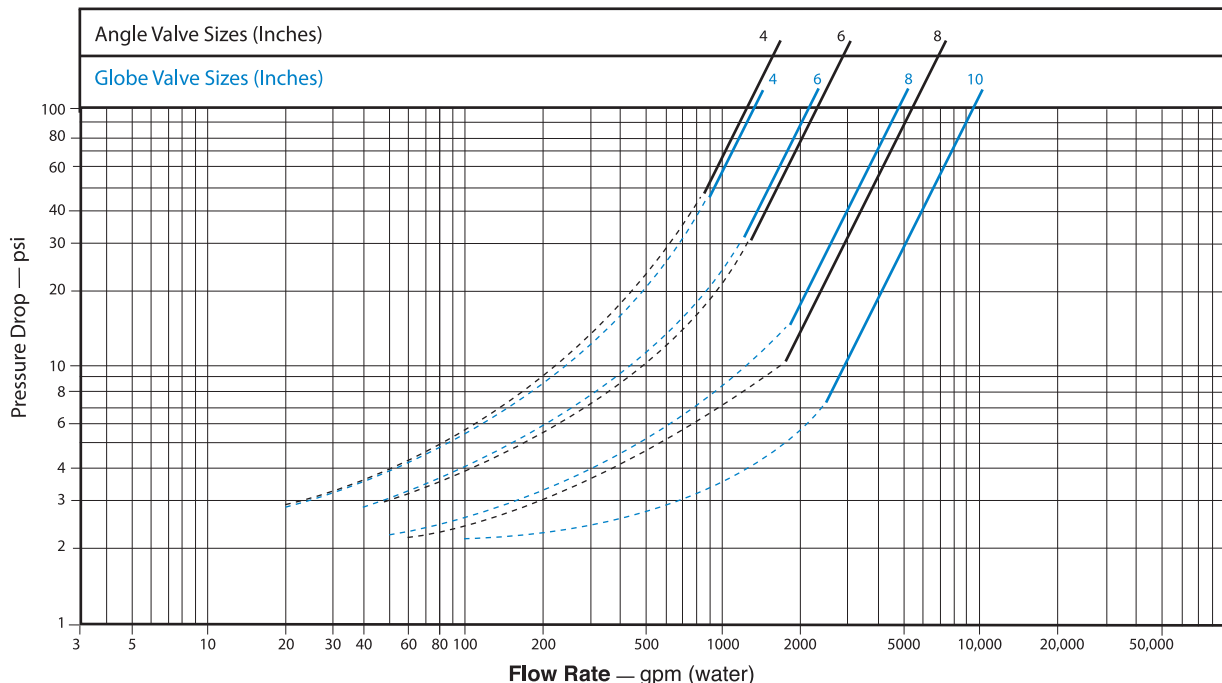

Dimensions

Model 100-31

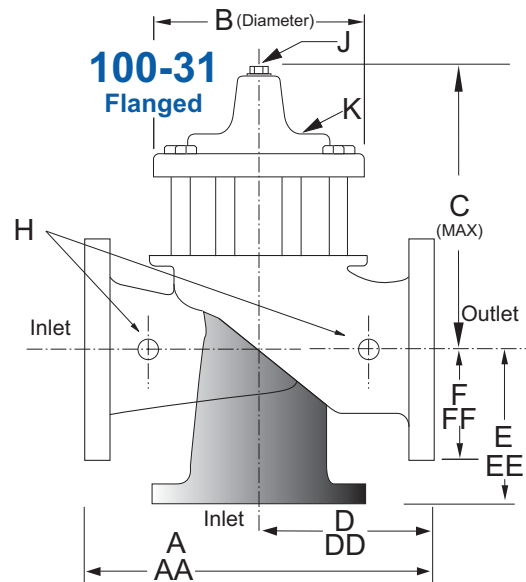

Valve Size (Inches)	4	6	8	10
A 150 ANSI	13.88	17.75	21.38	26.00
AA 300 ANSI	14.50	18.62	22.38	27.38
B Dia.	9.12	11.50	15.75	20.00
C Max.	8.62	15.25	20.25	23.75
D 150 ANSI	6.94	8.88	10.69	—
DD 300 ANSI	7.25	9.38	11.19	—
E 150 ANSI	5.50	6.75	7.25	—
EE 300 ANSI	5.81	7.25	7.75	—
F 150 ANSI	4.50	5.50	6.75	8.00
FF 300 ANSI	5.00	6.25	7.50	8.75
H NPT Body Tapping	.50	.75	.75	1
J NPT Cover Center Plug	.50	.75	.75	1
K NPT Cover Tapping	.50	.75	1	1
Valve Stem Internal Thread UNF	¼-28	¼-28	¾-24	¾-24
Stem Travel	0.6	0.8	1.7	2.3
Approx. Ship Wt. Lbs.	135	230	480	785

Valve Size (mm)	100	150	200	250
A 150 ANSI	353	451	543	660
AA 300 ANSI	368	473	568	695
B Dia.	232	292	400	508
C Max.	302	387	514	603
D 150 ANSI	176	226	272	—
DD 300 ANSI	184	238	284	—
E 150 ANSI	140	171	184	—
EE 300 ANSI	148	184	197	—
F 150 ANSI	114	140	171	203
FF 300 ANSI	127	159	191	222
H NPT Body Tapping	.50	.75	.75	1
J NPT Cover Center Plug	.50	.75	.75	1
K NPT Cover Tapping	.50	.75	1	1
Valve Stem Internal Thread UNF	¼-28	¼-28	¾-24	¾-24
Stem Travel	20	28	43	58
Approx. Ship Wt. Kgs.	61	104	218	356

Service and Installation

Cla-Val Control Valves operate with maximum efficiency when mounted in horizontal piping with the main valve cover UP, however, other positions are acceptable. Due to component size and weight of 10 inch and larger valves, installation with cover UP is advisable. We recommend isolation valves be installed on inlet and outlet for maintenance. Adequate space above and around the valve for service personnel should be considered essential. A regular maintenance program should be established based on the specific application data. However, we recommend a thorough inspection be done at least once a year. Consult factory for specific recommendations.