



# STANCOR PUMPS

## Chemical Resistant Submersible Drainage Pump

Type U6K: CHEM-RESIST



### Construction

- Pump:** Vertical centrifugal type, single stage, for submerged operation, with strainer base, open impeller (10 mm solids handling capacity) 1 1/4" MPT horizontal discharge.
- Bearings:** Combined shaft for motor and pump, two grease lubricated sealed ball bearings.
- Shaft Seal:** Pump end: Silicon carbide mechanical seal, unaffected by "dry" running.  
Motor end: radial lip seal.
- Motor:** Fully encapsulated submersible motor with built-in overload/thermal cut-out, water-tight enclosure, Class B insulation, 3600 R.P.M. Supplied with built-in level switch (type ES/DS) or with separate level control type CB. Suitable for continuous operation at a maximum water temperature of 40°C (104°F) with partly immersed motor, or 60°C max. (140°F) if fully immersed.
- Materials:** High impact, corrosion resistant plastic pump body, top cover, impeller. STAINLESS STEEL encapsulated motor, stainless steel rotor shaft, & fasteners.

The ideal pump for all drainage work. Lightweight, compact and easily portable, this unit can be relied upon for efficient and trouble free operation. The STANCOR CHEM-RESIST is particularly suitable for salt/seawater, effluent light solids & mild acids.

The HIGH-IMPACT, CORROSION RESTISTANT PLASTIC/STAINLESS STEEL U6K is especially suitable for effluent and similar environments where aluminum alloy and mild steel components would be subject to premature corrosion.

Fitted with mechanical seal and oil buffer chamber these pumps will give reliable service for long periods with minimum supervision and maintenance. A high quality product with all parts designed for long life.

These pumps are available **with built-in level switch** as illustrated above for fixed differential automatic level control. Alternately separate CB level control available as below.

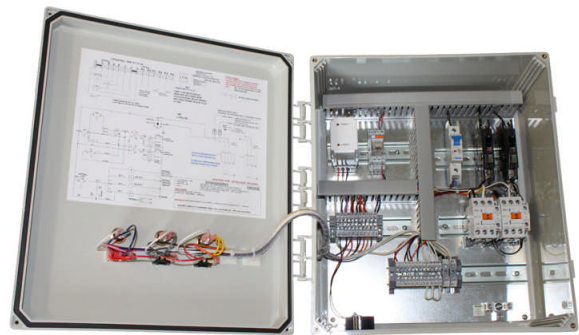

### SPECIFICATIONS

Type	Voltage	Motor Rating	RPM	kW input	F.L.C.	Thermal Protection	Weight
U6K-E(S)	115V or 220V	.75 HP	3600	800	7/4 Amp	Built-in	14.5 lbs.
U6K-D(S)	230V or 460V	.75 HP	3600	800	2.2/1.2 Amp	Built-in	14.5 lbs.

## Quality You Can Believe In

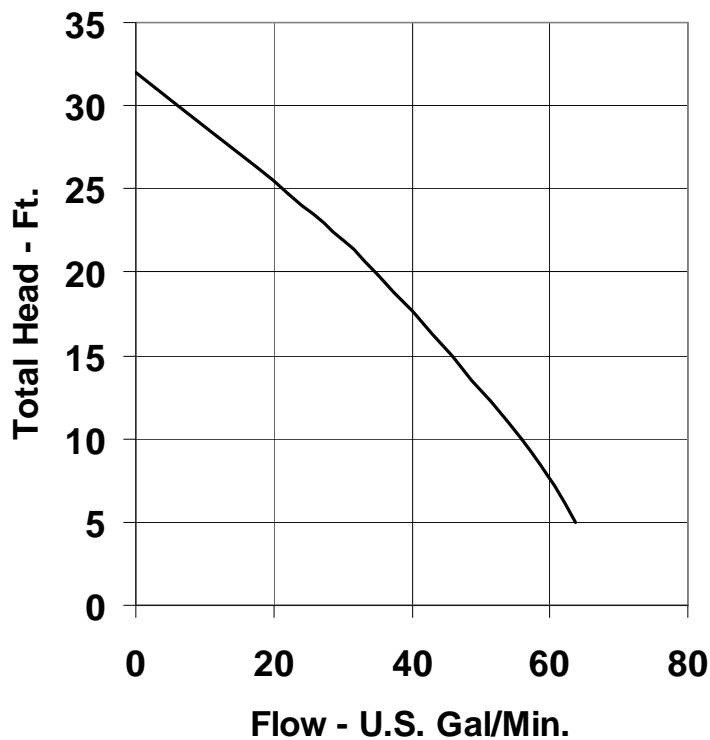

Chem-Resist  
 Type/U6K-E (manual) ES (automatic) -.75HP  
 Voltage 115 or 220 Volt  
 Model – Chem U6K-D (manual) DS (automatic)  
 Voltage 230 or 460 Volt

**Accessories**

Combined starting/level control float arm  
 Separate auto control CB-1000 for single phase pumps  
 Separate auto control CB-2000 for 3-phase pumps

Capacity ± 8%  
 Head ± 6%  
 HP absorbed ± 8%

**Dimensions**  
 inches

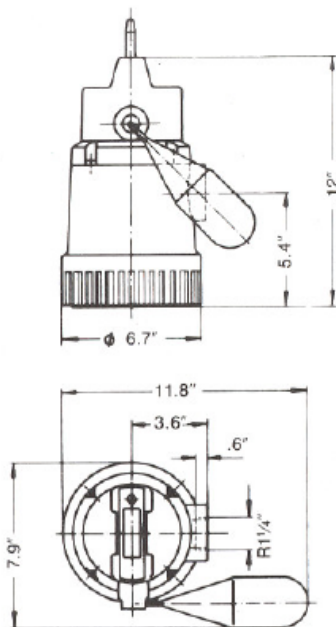

**Installation with built-in level control (type ES/DS)**  
 Min. sump area 16"X16"

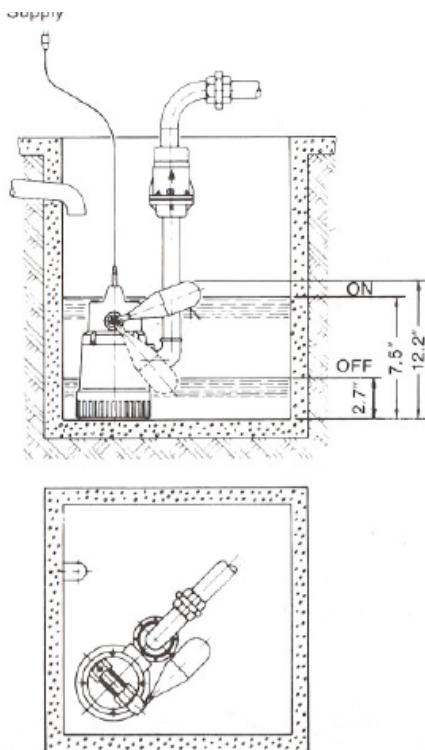

**Installation with separate level control (type CB)**  
 Min. sump area 16"X16"

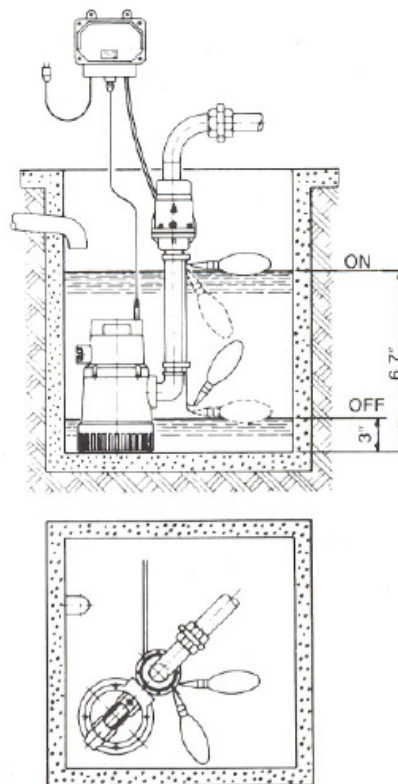

**STANCOR, INC.**

515 Fan Hill Road  
 Monroe, CT 06468

Ph: 203-268-7513 Fax: 203-268-7958  
 www.stancorpumps.com