

Powertrol Valve

- Drip-Tight, Positive Seating
- Service Without Removal From Line
- Threaded or Flanged Ends
- Globe or Angle Pattern
- Every Valve Factory Tested

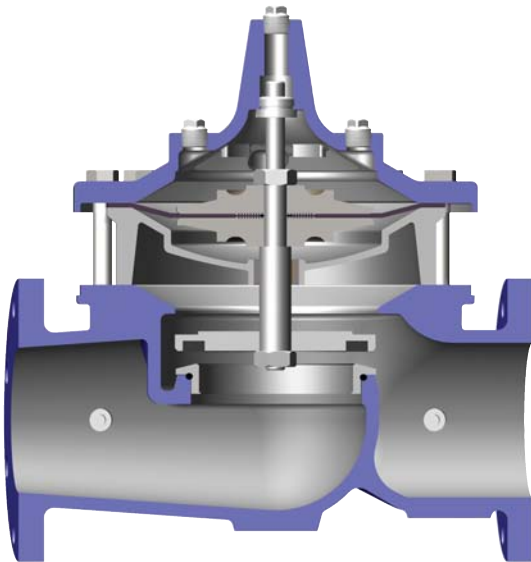

The Cla-Val Model 100-02 is a hydraulically operated, diaphragm actuated, globe, or angle pattern valve. It consists of four major components: body, intermediate chamber, diaphragm assembly, and cover. The diaphragm assembly is the only moving part.

The diaphragm assembly which is guided top and center by a precision machined stem, utilizes a non-wicking diaphragm of nylon fabric bonded with synthetic rubber. The diaphragm forms a seal between the cover chamber and intermediate chamber. A synthetic rubber disc retained on three and one half sides forms a drip-tight seal with the renewable seat when pressure is applied above the diaphragm. As pressure above the diaphragm is relieved and pressure is applied below the diaphragm, the valve opens wide for full flow. The rate of closing or opening can be controlled by modulating flow into or out of the diaphragm chambers.

The Model 100-02 is recommended where independent operating pressure is desired. Available in various materials and in a full range of sizes, with either threaded or flanged ends, its applications are many and varied.

Principle of Operation

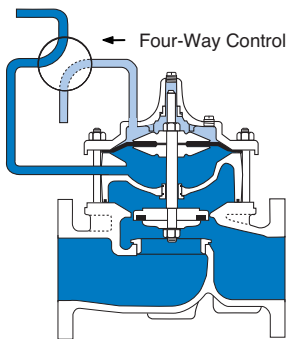

Full Open Operation

When operating pressure below the diaphragm is applied and operating pressure is relieved from the cover chamber and, the valve is held open, allowing full flow.

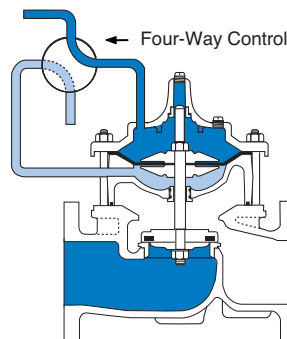

Tight Closing Operation

When pressure below the diaphragm is relieved and operating pressure is applied to the cover chamber, the valve closes drip-tight.

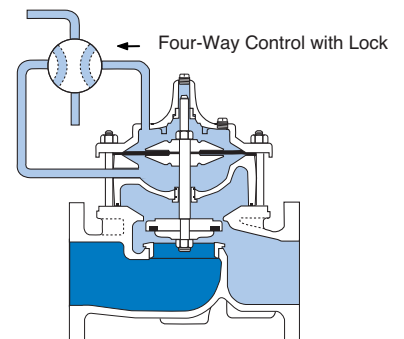

Modulating Action

The valve holds any intermediate position when operating pressure is equal above and below the diaphragm. A Cla-Val four-way pilot control with "lock" position can maintain this balance by stopping flow in the pilot control system.

Specifications

Model 100-02

Available Sizes

Pattern	Threaded	Flanged	Grooved End
Globe	3/8" - 3"	1 1/2" - 24"	1 1/2"-2"- 2 1/2"- 3"- 4"- 6"- 8"
Angle	1 1/2" - 3"	2" - 16"	2" - 3" - 4"

Operating Temp. Range

Fluids
-40° to 180° F

Pressure Ratings (Recommended Maximum Pressure - psi)

Valve Body & Cover		Pressure Class			
		Flanged			Threaded
Grade	Material	ANSI Standards*	150 Class	300† Class	End‡ Details
ASTM A536	Ductile Iron	B16.42	250	400	400
ASTM A216-WCB	Cast Steel	B16.5	285	400	400
ASTM B62	Bronze	B16.24	225	400	400

Note: * ANSI standards are for flange dimensions only.
 Flanged valves are available faced but not drilled.
 ‡ End Details machined to ANSI B2.1 specifications.
 † Consult factory when Maximum Operating Pressure Differential (MOPD) is greater than 400 PSID

“Valves for higher pressure are available; consult factory for details”

Materials

Component	Standard Material Combinations		
Body & Cover	Ductile Iron	Cast Steel	Bronze
Available Sizes	1 1/4" - 24"	1 1/4" - 16"	1 1/4" - 16"
Disc Retainer & Diaphragm Washer	Cast Iron	Cast Steel	Bronze
Trim: Disc Guide, Seat & Cover Bearing	Bronze is Standard Stainless Steel is Optional		
Disc	Buna-N® Rubber		
Diaphragm	Nylon Reinforced Buna-N® Rubber		
Stem, Nut & Spring	Stainless Steel		
For material options not listed, consult factory. Cla-Val manufactures valves in more than 50 different alloys.			

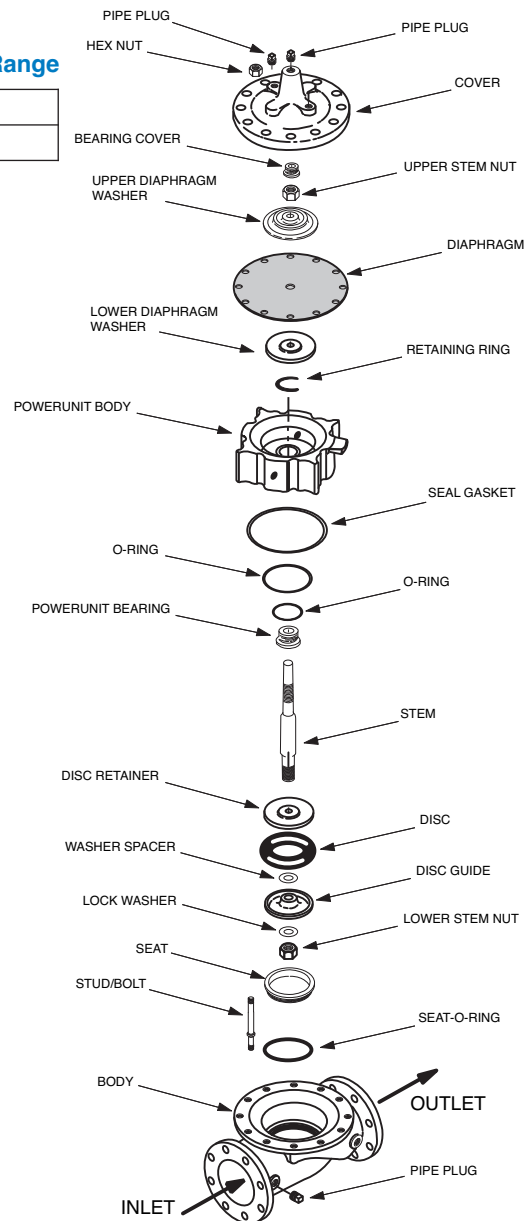

Options Epoxy Coating - suffix KC

This option NSF 61 Listed and FDA approved, fusion bonded epoxy coating is for use with cast iron, ductile iron or steel valves. This coating is resistant to various water conditions, certain acids, chemicals, solvents and alkalis. Epoxy coatings are applied in accordance with AWWA coating specifications C116-03.

Do not use with temperatures above 175° F

Viton® Rubber Parts - suffix KB

Optional diaphragm, disc and o-ring fabricated with Viton® synthetic rubber. Viton® is well suited for use with mineral acids, salt solutions, chlorinated hydrocarbons, and petroleum oils; and is primarily used in high temperature applications up to 250° F. Do not use with epoxy coating above 175°F.

Heavy Spring - suffix KH

The heavy spring option is used in applications where there is low differential pressure across the valve, and the additional spring force is needed to help the valve close. The option is best suited for valves used in on-off (non-modulating) service.

For assistance in selecting appropriate valve options or valves manufactured with special design requirements, please contact our Regional Sales Office or Factory.

For assistance in selecting appropriate valve options or valves manufactured with special design requirements, please contact our Regional Sales Office or Factory.

Valve Size		Inches	%	½	¾	1	1¼	1½	2	2½	3	4	6	8	10	12	14	16	18	20	24	30
		mm.	10	15	20	25	32	40	50	65	80	100	150	200	250	300	350	400	450	500	600	750
C _v Factor	Globe Pattern	Gal./Min. (gpm.)	1.8	6	8.5	13.3	30	32	54	85	115	200	440	770	1245	1725	2300	2940	3725	5345	7655	10150
	Angle Pattern	Litres/Sec. (l/s.)	.43	1.44	2.04	3.2	7.2	7.7	13	20	28	48	106	185	299	414	552	706	894	1286	1837	2436
Equivalent Length of Pipe	Globe Pattern	Feet (ft.)	25	7	16	23	19	37	51	53	85	116	211	291	347	467	422	503	612	595	628	1181
		Meters (m.)	7.6	2.2	4.8	7.1	5.7	12	15.5	16	26	35	64	89	106	142	129	154	187	181	192	552
	Angle Pattern	Feet (ft.)	—	—	—	—	—	46	40	37	58	80	139	176	217	222*	238*	247*	—	—	—	—
		Meters (m.)	—	—	—	—	—	14	12	12	18	25	43	54	66	68	73	75	—	—	—	—
K Factor	Globe Pattern		16.3	3.7	5.7	6.1	3.6	5.9	5.6	4.6	6.0	5.9	6.2	6.1	5.8	6.1	5.0	5.2	5.2	4.6	4.0	5.3
	Angle Pattern		—	—	—	—	—	7.1	4.4	3.3	4.1	4.1	4.1	3.7	3.6	2.9	2.8	2.6	—	—	—	—
Liquid Displaced from Cover Chamber When Valve Opens	Fl. Oz.		.12	.34	.34	.70	—	—	—	—	—	—	—	—	—	—	—	—	—	—	—	—
	U.S. Gal.		—	—	—	.02	.02	.03	.04	.08	.17	.53	1.26	2.51	4.0	6.5	9.6	11	12	29	42	
	ml		3.5	10.1	10.1	20.7	75.7	75.7	121	163	303	643	—	—	—	—	—	—	—	—	—	—
	Litres		—	—	—	—	—	—	—	—	—	—	2.0	4.8	9.5	15.1	24.6	36.2	41.6	45.4	109.8	197

*Estimated

C_v Factor

Formulas for computing C_v Factor, Flow (Q) and Pressure Drop (ΔP):

$$C_v = \frac{Q}{\sqrt{\Delta P}} \quad Q = C_v \sqrt{\Delta P} \quad \Delta P = \left(\frac{Q}{C_v} \right)^2$$

K Factor (Resistance Coefficient)

The Value of K is calculated from the formula: $K = \frac{894d^4}{C_v^2}$ (U.S. system units)

Equivalent Length of Pipe

Equivalent lengths of pipe (L) are determined from the formula: $L = \frac{Kd}{12f}$ (U.S. system units)

Fluid Velocity

Fluid velocity can be calculated from the following formula: $V = \frac{.4085 Q}{d^2}$ (U.S. system units)

Where:

C_v = U.S. (gpm) @ 1 psi differential at 60° F water or
 = (l/s) @ 1 bar (14.5 PSIG) differential at 15° C water

d = inside pipe diameter of Schedule 40 Steel Pipe (inches)

f = friction factor for clean, new Schedule 40 pipe (dimensionless) (from Cameron Hydraulic Data, 18th Edition, P 3-119)

K = Resistance Coefficient (calculated)

L = Equivalent Length of Pipe (feet)

Q = Flow Rate in U.S. (gpm) or (l/s)

V = Fluid Velocity (feet per second) or (meters per second)

ΔP = Pressure Drop in (psi) or (bar)

Model 100-02 Flow Chart (Based on normal flow through a wide open valve)

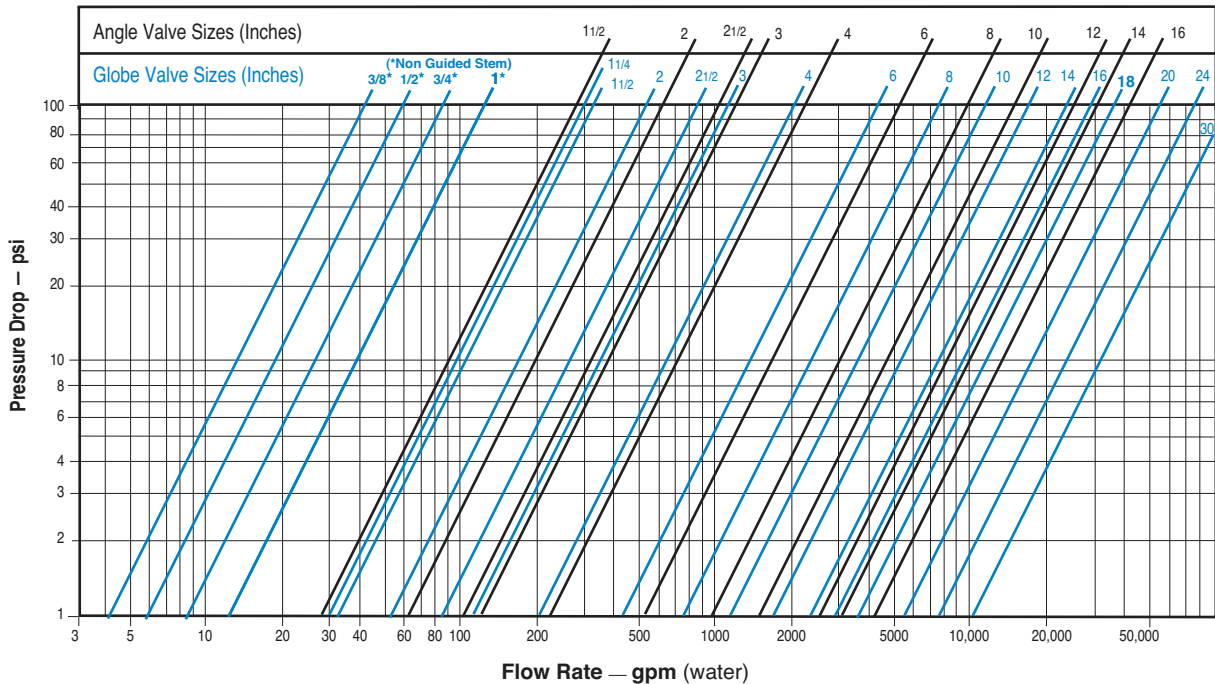

Dimensions

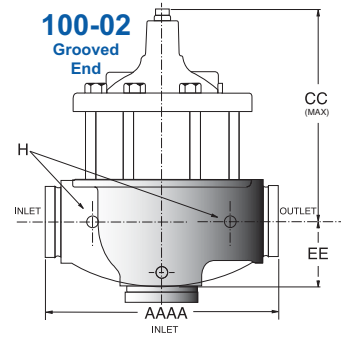
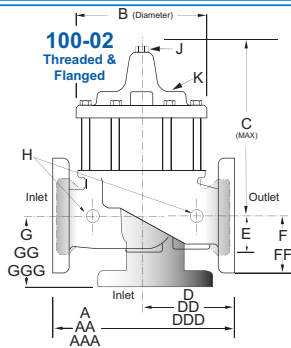

Valve Size (Inches)	3/8	1/2	3/4	1	1 1/4	1 1/2	2	2 1/2	3	4	6	8	10	12	14	16	18	20	24	30
A Threaded	2.75	3.50	3.50	5.12	7.25	7.25	9.38	11.00	12.50	—	—	—	—	—	—	—	—	—	—	—
AA 150 ANSI	—	—	—	—	8.50	9.38	11.00	12.00	15.00	20.00	25.38	29.75	34.00	39.00	41.38	46.00	52.00	61.50	63.00	—
AAA 300 ANSI	—	—	—	—	9.00	10.00	11.62	13.25	15.62	21.00	26.38	31.12	35.50	40.50	43.50	47.64	53.62	63.24	64.50	—
AAAA Grooved End	—	—	—	—	8.50	9.00	11.00	12.50	15.00	20.00	25.38	—	—	—	—	—	—	—	—	—
B Dia.	2.50	3.12	3.12	4.38	5.62	5.62	6.62	8.00	9.12	11.50	15.75	20.00	23.62	28.00	32.75	35.50	41.50	45.00	53.16	56.00
C Max.	2.33	5.88	5.88	6.25	7.62	7.62	8.56	10.31	11.19	14.25	18.44	21.81	23.38	29.31	32.12	35.00	49.43	53.09	56.50	68.70
CC Max. Grooved End	—	—	—	—	6.87	7.81	9.63	10.25	13.50	17.18	20.43	—	—	—	—	—	—	—	—	—
D Threaded	—	—	—	3.25	3.25	4.75	5.50	6.25	—	—	—	—	—	—	—	—	—	—	—	—
DD 150 ANSI	—	—	—	—	4.00	4.75	5.50	6.00	7.50	10.00	12.69	14.88	17.00	19.50	20.81	—	—	—	—	—
DDD 300 ANSI	—	—	—	—	4.25	5.00	5.88	6.38	7.88	10.50	13.25	15.56	17.75	20.25	21.62	—	—	—	—	—
DDDD Grooved End	—	—	—	—	4.75	—	6.00	7.50	—	—	—	—	—	—	—	—	—	—	—	—
E	1.25	0.88	0.88	1.63	1.12	1.12	1.50	1.69	2.06	3.19	4.31	5.31	9.25	10.75	12.62	15.50	12.95	15.00	17.75	21.31
EE Grooved End	—	—	—	—	2.00	2.50	2.88	3.12	4.25	6.00	7.56	—	—	—	—	—	—	—	—	—
F 150 ANSI	—	—	—	—	2.50	3.00	3.50	3.75	4.50	5.50	6.75	8.00	9.50	10.50	11.75	15.00	16.50	19.25	22.50	—
FF 300 ANSI	—	—	—	—	3.06	3.25	3.75	4.13	5.00	6.25	7.50	8.75	10.25	11.50	12.75	15.00	16.50	19.25	24.00	—
G Threaded	—	—	—	—	1.88	1.88	3.25	4.00	4.50	—	—	—	—	—	—	—	—	—	—	—
GG 150 ANSI	—	—	—	—	4.00	3.25	4.00	4.00	5.00	6.00	8.00	8.62	13.75	14.88	15.69	—	—	—	—	—
GGG 300 ANSI	—	—	—	—	4.25	3.50	4.31	4.38	5.31	6.50	8.50	9.31	14.50	15.62	16.50	—	—	—	—	—
GGGG Grooved End	—	—	—	—	3.25	—	4.25	5.00	—	—	—	—	—	—	—	—	—	—	—	—
H NPT Body Tapping	—	.125	.125	.25	.375	.375	.375	.50	.50	.75	.75	1	1	1	1	1	1	1	1	2
J NPT Cover Center Plug	.125	.125	.125	.25	.25	.25	.50	.50	.50	.75	.75	1	1	1.25	1.50	2	1.5	1.50	1.50	2
K NPT Cover Tapping	—	.125	.125	.25	.375	.375	.375	.50	.50	.75	.75	1	1	1	1	1	1	1	1	2
Valve Stem Internal Thread UNF	—	—	—	—	10-32	10-32	10-32	10-32	1/4-28	1/4-28	3/8-24	3/8-24	3/8-24	3/8-24	3/8-24	3/8-24	1/2-20	3/4-16	3/4-16	3/4-16
Stem Travel	—	—	—	—	0.4	0.4	0.6	0.7	0.8	1.1	1.7	2.3	2.8	3.4	4.0	4.5	5.1	5.63	6.75	7.5
Approx. Ship Wt. Lbs.	8	8	8	13	22	22	40	65	95	190	320	650	940	1675	2460	3100	4300	5400	8150	10300

Note: The top two flange holes on valve size 36 are threaded to 1 1/2"-6 UNC.

Valve Size (mm)	10	15	20	25	32	40	50	65	80	100	150	200	250	300	350	400	450	500	600	750
A Threaded	70	89	89	130	184	184	238	279	318	—	—	—	—	—	—	—	—	—	—	—
AA 150 ANSI	—	—	—	—	—	216	238	279	305	381	508	645	756	864	991	1051	1168	1321	1562	1600
AAA 300 ANSI	—	—	—	—	—	229	254	295	337	397	533	670	790	902	1029	1105	1210	1362	1606	1638
AAAA Grooved End	—	—	—	—	216	216	228	279	318	381	508	645	—	—	—	—	—	—	—	—
B Dia.	64	80	80	111	143	143	168	203	232	292	400	508	600	711	832	902	1054	1143	1350	1422
C Max.	59	149	149	159	194	194	217	262	284	362	468	554	594	744	816	889	1255	1348	1435	1745
CC Max. Grooved End	—	—	—	—	174	174	198	245	260	343	436	519	—	—	—	—	—	—	—	—
D Threaded	—	—	—	—	83	83	121	140	159	—	—	—	—	—	—	—	—	—	—	—
DD 150 ANSI	—	—	—	—	—	102	121	140	152	191	254	322	378	432	495	528	—	—	—	—
DDD 300 ANSI	—	—	—	—	—	108	127	149	162	200	267	337	395	451	514	549	—	—	—	—
DDDD Grooved End	—	—	—	—	—	121	—	152	191	—	—	—	—	—	—	—	—	—	—	—
E	32	23	23	42	29	29	38	43	52	81	110	135	235	273	321	394	329	381	451	541
EE Grooved End	—	—	—	—	52	52	64	73	79	108	152	192	—	—	—	—	—	—	—	—
F 150 ANSI	—	—	—	—	—	64	76	89	95	114	140	171	203	241	267	298	381	419	489	572
FF 300 ANSI	—	—	—	—	—	78	83	95	105	127	159	191	222	260	292	324	381	419	489	610
G Threaded	—	—	—	—	48	48	83	102	114	—	—	—	—	—	—	—	—	—	—	—
GG 150 ANSI	—	—	—	—	102	83	102	102	127	152	203	219	349	378	399	—	—	—	—	—
GGG 300 ANSI	—	—	—	—	102	89	110	111	135	165	216	236	368	397	419	—	—	—	—	—
GGGG Grooved End	—	—	—	—	—	83	—	108	127	—	—	—	—	—	—	—	—	—	—	—
H NPT Body Tapping	—	.125	.125	.25	.375	.375	.375	.50	.50	.75	.75	1	1	1	1	1	1	1	1	2
J NPT Cover Center Plug	.125	.125	.125	.25	.25	.25	.50	.50	.50	.75	.75	1	1	1.25	1.50	2	1.5	1.50	1.50	2
K NPT Cover Tapping	—	.125	.125	.25	.375	.375	.375	.50	.50	.75	.75	1	1	1	1	1	1	1	1	2
Valve Stem Internal Thread UNF	—	—	—	—	10-32	10-32	10-32	10-32	1/4-28	1/4-28	3/8-24	3/8-24	3/8-24	3/8-24	3/8-24	3/8-24	1/2-20	3/4-16	3/4-16	3/4-16
Stem Travel	—	—	—	—	10	10	15	18	20	28	43	58	71	86	102	114	130	143	171	191
Approx. Ship Wt. Kgs.	1.4	1.4	1.4	6	10	10	18	30	43	86	145	295	426	760	1116	1406	1950	2449	3696	4672

CLA-VAL Control Valves operate with maximum efficiency when mounted in horizontal piping with the main valve cover UP, however, other positions are acceptable. Due to component size and weight of 8 inch and larger valves, installation with cover UP is advisable. We recommend isolation valves be installed on inlet and outlet for maintenance. Adequate space above and around the valve for service personnel should be considered essential. A regular maintenance program should be established based on the specific application data. However, we recommend a thorough inspection be done at least once a year. Consult factory for specific recommendations.