



# Series 33A

## Air Release & Vacuum Breaker Valve

- High Performance Single Body Design
- Threaded or Flanged Inlet

### Sizes:

1", 2", 3" and 4" NPT  
Optional 150 or 300 Class ANSI Flange Inlet

### Pressure Rating

500 psi Maximum  
Body and Cover  
300 psi Working

### Materials

Body and Cover:  
Ductile Iron ASTM A536 65-45-12  
Other Materials Available, Consult Factory  
Float: Stainless Steel T304  
Internal Parts: Stainless Steel and Delrin  
Seals: Nitrile Rubber

### Temperature Range

Water to 180° F

### Optional:

1. Fusion epoxy lined and coated extra cost. Specify with Suffix Letter "KC".
2. For Well Service, Install extra cost Throttling Device on Outlet. Consult Factory

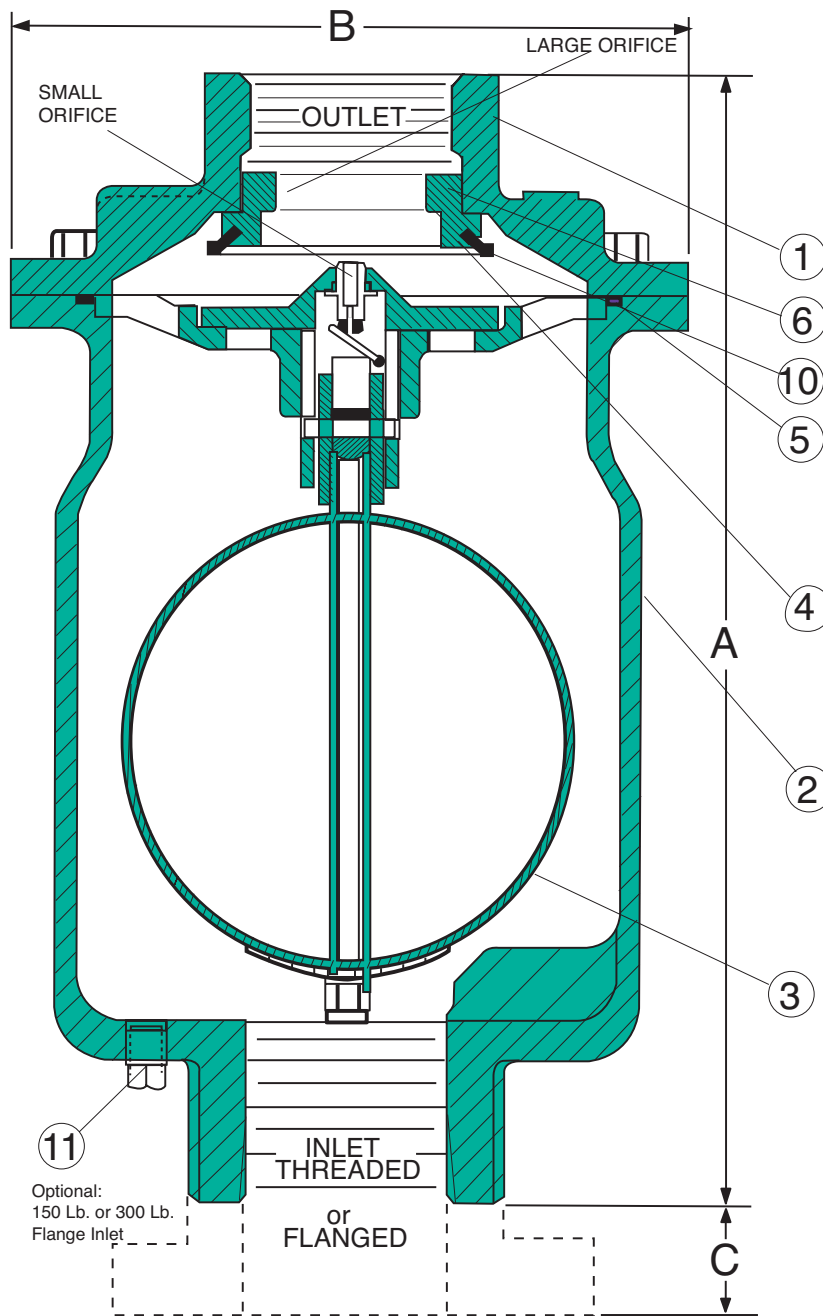

Valve Size	1"	2"	3"	4"
A	9.10	13.50	12.75	12.75
B	6.25	7.50	9.00	9.00
C (150 Lb.)	--	.62	.75	.94
C (300 Lb.)	--	.88	1.12	1.12
Inlet (NPT)	1" NPT	2" NPT	3" NPT	4" NPT
Outlet (NPT)	1" NPT	2" NPT	4" NPT	4" NPT
Shipping Wt. (Lbs.)*	25	29	38	40
Max. Operating PSI (Std. Orifice)	300	500	300	300
Max. Operating PSI (with .076 Orifice)	300	500	450	450

\*Approximate

Part No.	Qty.	Description	Part No.	Qty.	Description
1	1	Cover	7	8	Bolt Hex Nut
2	1	Body	8	2	Screw Drive
3*	1	Float Ball Assembly	9	1	Nameplate
4*	1	Seal Rign	10	1	O-Ring
5*	1	O-Ring	11	1	1/4" NPT Drain Plug
6*	1	Seat	*Recommended Spare Parts Kit		