

Suitable for Emergency, Peak and Prime
Power System Applications

Low Voltage Automatic Transfer Switch Systems



ASCO[®]

THE POWER AUTHORITY

ASCO® THE POWER AUTHORITY

ASCO's experience and commitment to excellence in designing and building Emergency Power Control Systems for any application has made us the premier manufacturing and service organization in the world.

For over 100 years we have built upon a tradition of providing our customers a full range of high performance and quality products. ASCO's experience spans the history of the power control industry and since 1888 we have set the standard for the entire industry. Our reputation as the leader in emergency power control equipment speaks to the quality of our products and the dedication of our people.

ASCO operates two modern facilities dedicated to manufacturing low and medium voltage power control systems. Located in Parsippany, New Jersey and Stockton, California, these manufacturing plants produce state-of-the-art power control systems for emergency or standby power generation, peak load shaving, prime power, parallel with utility, co-generation, emergency load management and power distribution. These products are designed and manufactured to meet and exceed the demands of a growing global market.

Our ongoing dedication to research & development and extensive testing have confirmed ASCO products as the industry standard. Since our beginnings this same dedication has established ASCO as the pioneering innovator in the emergency power control industry. This commitment continues to set ASCO apart as the company that stands at the threshold of new technologies and has resulted in a long list of industry firsts throughout the years.

ASCO has always been committed to providing a full range of products with only one thing in mind... transferring power from an available source to a critical load. Telecommunications systems, data networks, industrial processes and critical installations demand proven emergency and standby power transfer solutions. As the worlds leader in emergency and standby power, ASCO products and systems safeguard your business... because we keep your power on.



Fig. 1 Parsippany, New Jersey, USA



Fig. 2 Stockton, California, USA

ASCO[®] Automatic Transfer Systems

Product Overview

Content	Page
Service Entrance Rated Transfer System	4
ATS Switchboard	5
Two Source Automatic Transfer System	6
Three Source ATS System	7
Three Source Priority System	8
Soft Load Transfer System	9
Custom Applications	10-11

For more information on ASCO Automatic Transfer Systems contact your nearest ASCO source at 800-937-ASCO or visit our website at www.asco.com.

ASCO® Service Entrance Rated Transfer System

ASCO service entrance rated transfer systems are designed for automatic switching of loads between the utility source and an alternate source of power. The transfer system also contains a disconnect device on the normal source, plus a disconnect link on the utility neutral, and a disconnect link between neutral and ground. If the utility source is Y connected, the voltage is greater than 250 volts phase to neutral and the system continuous current is greater than 1000 amperes, the utility disconnect device will be equipped with ground fault trip.

Figure 3 shows a typical service entrance rated transfer system with a 1200 ampere automatic transfer switch and a 1200 ampere utility circuit breaker.



Fig. 3 Service entrance rated transfer system.

Product Features

- The utility disconnect device will be equipped with ground fault trip if the voltage between neutral and ground is greater than 250 volts, and the continuous current is greater than 1000 amperes.
- Disconnect link for the utility neutral bus.
- Disconnect link between the neutral bus and the ground bus.
- Meets all NEC requirements for service entrance rating, and is labeled to UL 891 standards.
- Available up through 4000 amperes using ASCO 940, 962, 434, 436 and ASCO's new 7000 series automatic transfer switches.

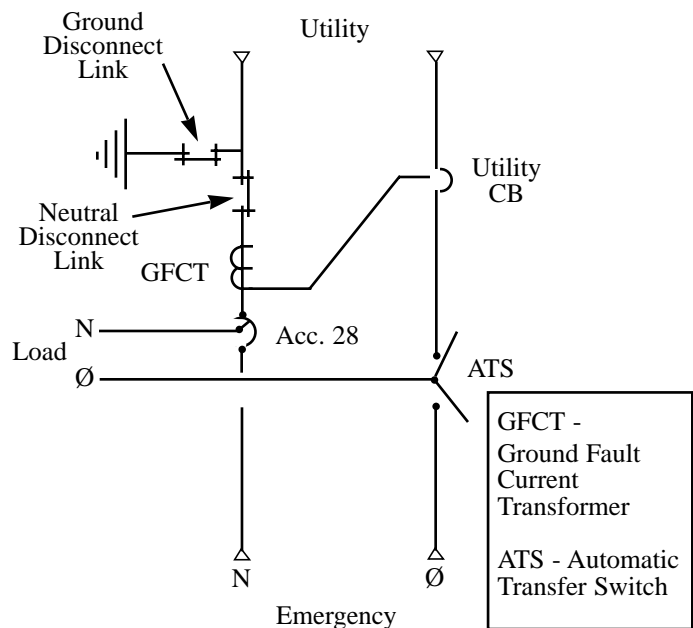

Fig. 4 One line diagram of the service entrance rated transfer system shown in figure 3.

ASCO[®] ATS Switchboards

An automatic transfer switchboard is a switchboard containing two or more automatic transfer switches in a common line-up. The switchboard shown in figure 5 contains two ASCO 962, 2000 ampere, automatic transfer bypass-isolation switches with circuit breakers on the normal and load side of each switch. An ammeter and voltmeter are also located on the load side of each switch.



Fig. 5 Automatic transfer switchboard.

Product Features

- Connects multiple automatic transfer switches together in a common switchboard.
- Optional normal and/or emergency circuit breakers for overcurrent protection.
- Optional distribution circuit breakers of the size and type to meet customer load requirements.
- Optional instrument meters for normal, emergency, or load for local monitoring.
- Designs can be provided with a UL 891 Label containing up through a 10,000 ampere main bus.
- Utilizes ASCO 940, 962, 434, 436 and ASCO's new 7000 series automatic transfer switches.

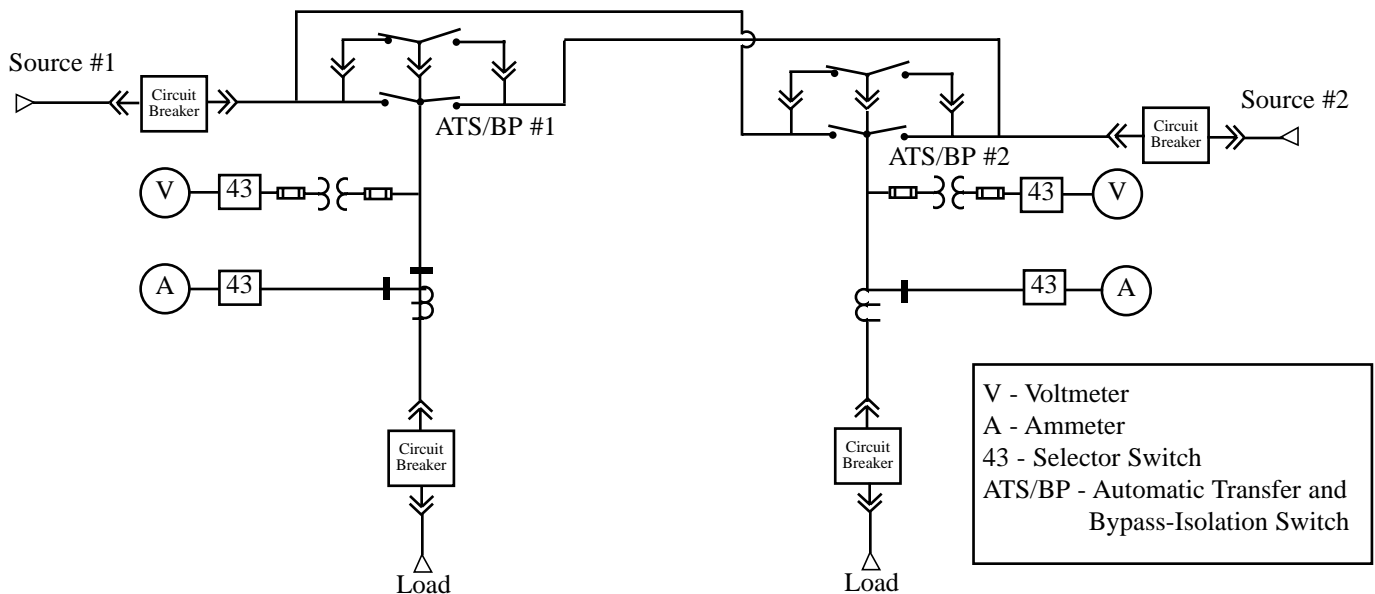

Fig. 6 One line diagram of the automatic transfer switchboard shown in figure 5.

ASCO® Two Source Automatic Transfer System

ASCO two-source systems are designed for automatic switching of loads between the utility source and an alternate source of power. Upon the loss of the utility power source, the system provides an automatic start signal to the alternate source of power. Once the alternate source has reached proper voltage and frequency, the system transfers the critical load from the utility source to the alternate power source. When normal power is restored the controls will retransfer the load to the utility and signal shutdown of the alternate power source after allowing a cooldown period.

ASCO two-source systems include an automatic transfer switch, plus any or all of the following options; automatic engine starting controls, overcurrent protection for both emergency and normal sources, instrument meters, status annunciation, and audible alarm. The systems are designed to NEMA switchboard construction and are labeled to UL 891 standards.

These systems can be designed for top cable entrance, bottom cable entrance or bus duct connections.

The system shown in figure 7 contains a 1200 ampere closed transition automatic transfer switch with a 1200 ampere utility circuit breaker, multi-purpose meter, reverse power relay, and an alarm horn.



Fig. 7 Two source system with main circuit breaker, protective relaying and automatic transfer switch rated 1200 amperes.

Product Features

- Normal, emergency, and/or load circuit breakers.
- Protective relaying (as required).
- Optional instrument meters for normal, emergency, or load for local monitoring.
- Designs are based on NEMA and UL 891 standards.
- Optional engine start control logic and/or load control logic.
- Designs available up to 4000 amperes utilizing ASCO 940, 962, 434, 436 and ASCO's new 7000 series automatic transfer switches.

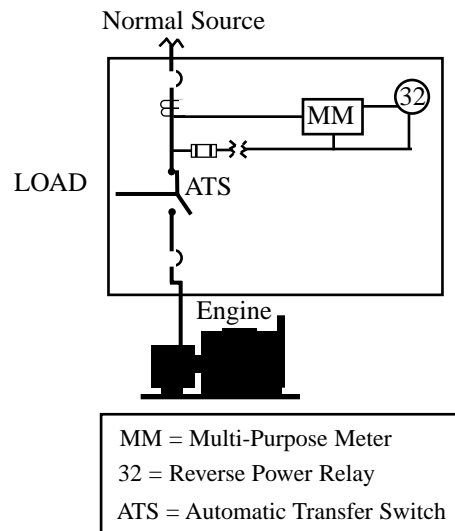

Fig. 8 One line diagram of the two source automatic transfer system shown in figure 7.

ASCO® Three Source Automatic Transfer System

ASCO three-source systems are similar to ASCO two-source systems except that a second alternate power source is added to back up the first if that power source fails. Upon the loss of the utility power source, the system provides all necessary controls to start both alternate power sources. The critical loads are automatically transferred to the first alternate power source that achieves acceptable voltage and frequency. The second alternate power source is then automatically shutdown after a time delay and cooldown period. If the first alternate power source fails, the second alternative power source will be automatically re-started and the load will be transferred from the first alternative power source to the second alternative power source. When the normal power is restored, the controls automatically retransfer the load to the utility power source.

Figure 9 shows a three source automatic transfer system with two 940 automatic transfer switches and three distribution circuit breakers for feeding critical loads.



Fig. 9 Three source automatic transfer system.

Product Features

- Control logic for selecting between the alternative power sources.
- Normal, emergency, and/or load circuit breakers.
- Protective relaying (as required).
- Optional instrument meters for normal, emergency, or load for local monitoring.
- Designs are based on NEMA and UL 891 standards.
- Optional engine start control logic and/or load control logic.
- Designs available up to 4000 amperes utilizing ASCO 940, 962, 434, 436 and ASCO's new 7000 series automatic transfer switches.

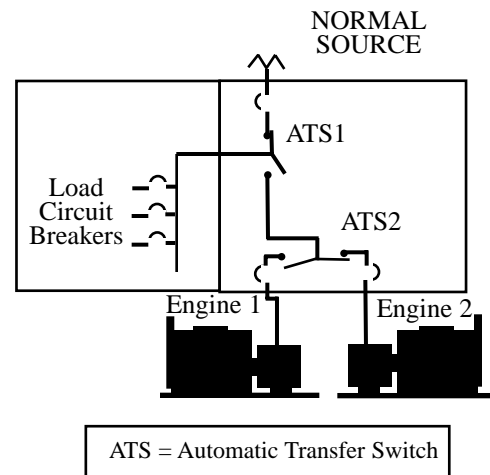

Fig. 10 One line diagram of the three source automatic transfer system shown in figure 9.

ASCO® Three Source Priority System



Fig. 11 Three source priority system.

ASCO three-source priority systems are similar to the ASCO three-source systems except they protect two critical loads rather than one critical load. Upon the loss of the utility power source, the system provides all necessary controls to start both alternative power sources. The most critical load is transferred to the first alternate power source that achieves acceptable voltage and frequency. The second most critical load is then transferred to the second alternate power source when it achieves acceptable voltage and frequency. If the alternate power source feeding the most critical load should fail, the most critical load would be transferred to the second alternate power source and the second most critical load would be shed. When the utility power source is restored, the system controls automatically retransfer the loads to the utility and both alternate power sources are run for a cooldown period and then shutdown.

Figure 11 shows a three source priority system containing a priority selector transfer switch (ATS-2) and seven distribution circuit breakers. ATS-1 and ATS-2 are wall mounted automatic transfer switches and are not shown in this line-up.

Product Features

- Priority selector transfer switch.
- Control logic for selecting between alternate power sources
- Normal, emergency, and/or load circuit breakers.
- Protective relaying (as required).
- Optional instrument meters for normal, emergency, or load for local monitoring.
- Designs are based on NEMA and UL 891 standards.
- Optional engine start control logic and/or load control logic.
- Designs available up through 4000 amperes utilizing ASCO 940, 962, 434, 436 and ASCO's new 7000 series automatic transfer switches.

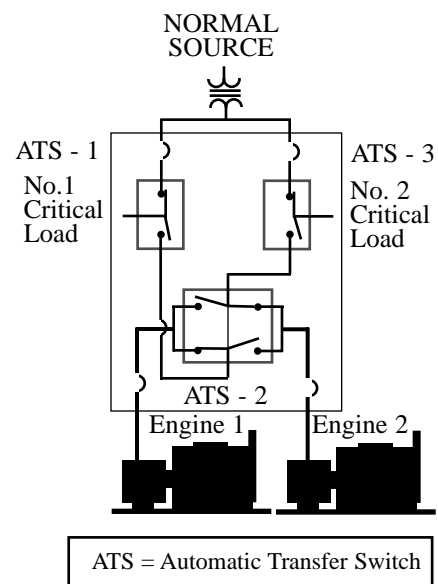

Fig. 12 One line diagram of the three source priority system shown in figure 11.

ASCO® Soft Load Transfer System

ASCO soft load closed transition transfer switches provide a make-before-break transfer of a building load from a utility power source to an alternate power source. This system automatically brings the engine generator into synchronism with the utility source, then gradually shifts the load from the utility to the engine generator with virtually no voltage or frequency fluctuations.

Figure 13 shows a typical soft load transfer system containing an ASCO closed transition transfer switch.

Product Features

- Open or closed transition transfer between normal and emergency.
- Emergency or peak shave mode of operation.
- Engine start control logic and load control logic.
- Available configurations include either an ASCO 434, 436 or ASCO's new 7000 Series closed transition transfer switches through 4000 amperes. The transfer system configuration can also accommodate power circuit breakers.
- Normal and emergency circuit breakers can be provided when using a transfer switch for overcurrent protection.
- Full manual paralleling operation (standard).
- Protective relaying (as required).
- Optional instrument meters for normal, emergency, or load for local monitoring.
- Designs are based on NEMA and UL 891 standards.



Fig. 13 Soft load transfer system.

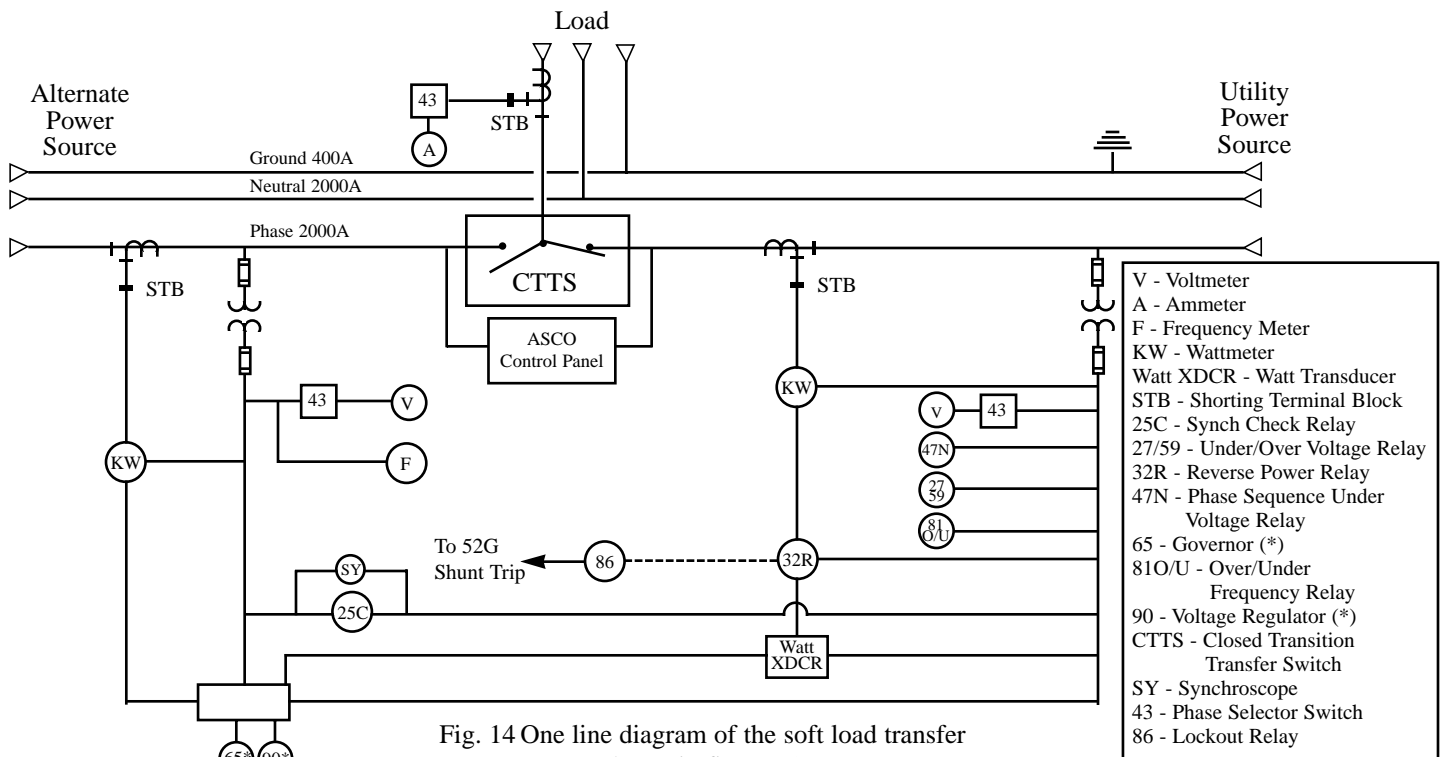

Fig. 14 One line diagram of the soft load transfer system shown in figure 13.

Note: * Furnished by alternate power source supplier

ASCO® Custom Applications



Fig. 15 Selective load system.

Selective Load System

Selective load systems allow one load at a time to be operated when normal power fails. The system uses the minimum amount of auxiliary power for operation so the alternate power source can be sized for only one load at a time. The selective load system can be designed to handle any number of loads in any combination of sizes to suit the customers needs.

The only interfacing between the ASCO selective load system and the load controls are power cables.

The system can be used with any electrical load application where only one load out of a number of loads are to be operated from the alternate power source at one time. A typical application is with multiple banks of elevators when you want to enable only one elevator at a time to operate under emergency conditions.

The system can be supplied with a separate control panel, which allows loads to be selected from a remote location.

Figure 15 shows a typical selective load system with transfer switches for five loads. The control panel has a selector switch and position indication of each load.

Transfer Switch with Distribution System

Transfer switches can be provided with normal and emergency circuit breakers for overcurrent protection, plus any combination of distribution circuit breakers, bolted pressure switches, or fusible disconnect switches.

Figure 16 shows a switchboard containing a circuit breaker on the normal source of the automatic transfer switch plus a distribution panelboard of molded case circuit breakers to protect critical downstream loads. The cubicle on the left end of the system provides monitoring and control of the distribution system.



Fig. 16 Transfer switch with distribution.



Fig. 17 Transfer switch with bottom bus riser.

Transfer Switch with Bottom Bus Risers

Figure 17 shows a 4000 ampere transfer switch with bus risers for bottom entry bus duct on both the normal source and load connections. The emergency side of the transfer switch has lugs for cable connections from the top of the enclosure. This demonstrates our capability to meet custom service entry requirements.

Transfer Switch in an Outdoor Enclosure

Figure 18 shows a transfer switch with a fuse disconnect switch on the normal side. The switch is in a non-walk-in NEMA 3R outdoor enclosure. The outdoor enclosure is designed for front and rear entry only with three point catches on the doors as well as provisions for padlocking.

Outdoor enclosures are available for all ASCO transfer switch products.



Fig. 18 Transfer switch in an outdoor enclosure.

Automatic Switch Co.

800-937-ASCO

www.asco.com

ASIA • AUSTRALIA • BRAZIL • CANADA • GERMANY • JAPAN • MEXICO • SOUTH AFRICA • UNITED ARAB EMIRATES • UNITED KINGDOM • UNITED STATES

Florham Park, New Jersey 07932 USA

Publication 3049

© Automatic Switch Co. 1998

Printed in the U.S.A.