



60-08
(Full Internal Port)

— MODEL —

660-08
(Reduced Internal Port)

Booster Pump Control Valve with High Capacity Pilot System



- Designed for Larger Sized Pump Stations
- Low Head Loss
- Built-in Check Valve
- Opening and Closing Rates Separately Adjusted
- Proven Reliable Design

The Cla-Val Model 60-08/660-08 Pump Control Valve is a pilot-operated valve designed for installation on the discharge of booster pumps to eliminate pipeline surges caused by the starting and stopping of the pump.

The pump starts against a closed valve. When the pump is started, the solenoid control is energized and the valve begins to open slowly, gradually increasing line pressure to full pumping head. When the pump is signaled to shut-off, the solenoid control is de-energized and the valve begins to close slowly, gradually reducing flow while the pump continues to run. When the valve is closed, a limit switch assembly, which serves as an electrical interlock between the valve and the pump, releases the pump starter and the pump stops.

Should a power failure occur, a built-in, lift-type check valve closes the moment flow stops, preventing reverse flow regardless of solenoid or diaphragm assembly position.

Schematic Diagram

Item Description

- 1 Powercheck (Main Valve)
- 2 CV Flow Control
- 3 CS4SM 4-Way Solenoid Control
- 4 X105LCW Switch Assembly
- 5 CVS-1 Shuttle Valve

Optional Features

Item Description

- A X46A Flow Clean Strainer
- B CK2 (Isolation Valve)
- P X141 Pressure Gauge
- Y X43 "Y" Strainer

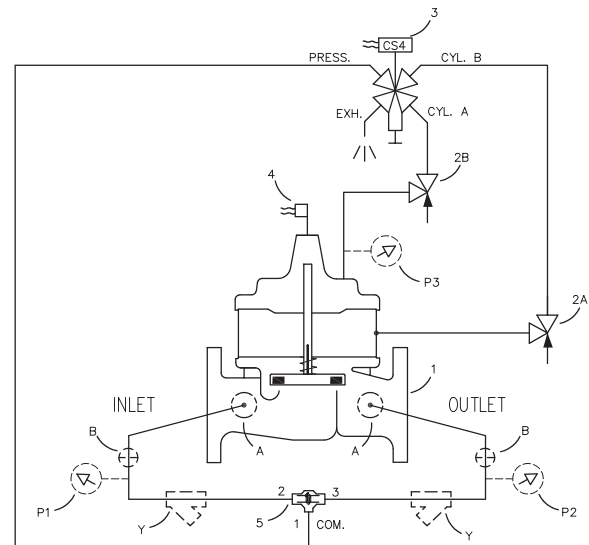

Typical Installation

Install Model 60-08/660-08 valve as shown. Flexible conduit should be used for electrical connections to the solenoid control and the limit switch. A Model 52-02/652-03 Surge Anticipator Valve is recommended for power failure protection.

Note: For optimum operation of built-in check feature, installation must be with valve stem vertically up.

The Model 60-08/660-08 is for 10" and larger valves or when the pressure is above 300 psi.

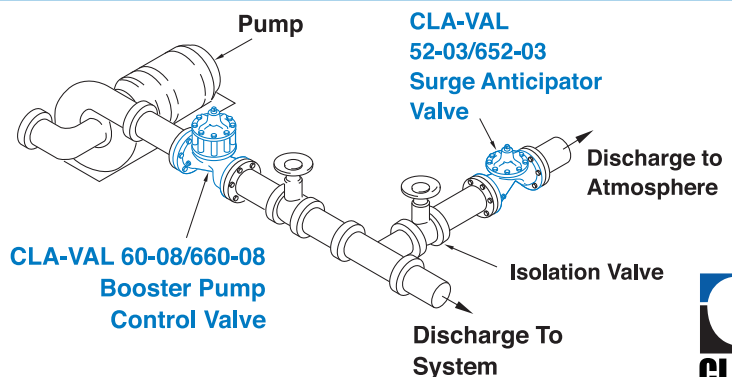

Sequence Of Operation

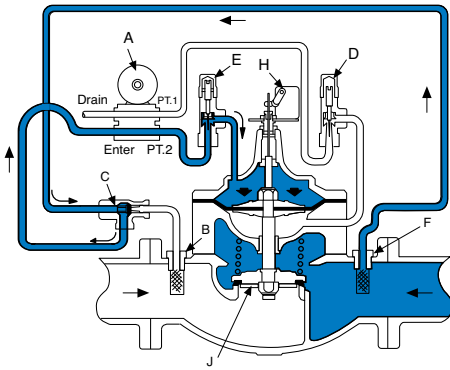

Pump Off...

With pump off, line pressure exists above the diaphragm holding the main valve closed.

Shuttle valve C always supplies highest pressure to solenoid control A through strainers B and F.

If power failure occurs when valve is open, the built-in check valve J closes immediately to prevent reverse flow.

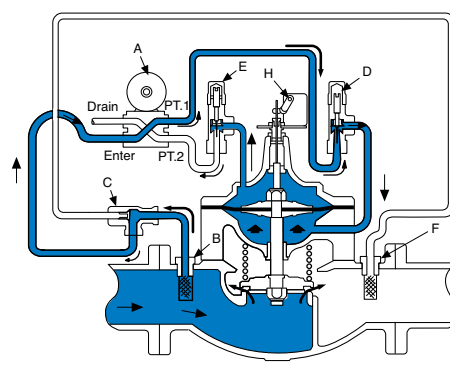

Starting Cycle...

Starting switch closes, pump starts, solenoid control energizes.

Upstream fluid flows to chamber below main valve diaphragm through strainer B, shuttle valve C, solenoid control A, and closing rate flow control D.

Valve opens slowly as fluid from diaphragm chamber is gradually released to atmosphere through opening rate flow control E and solenoid control A.

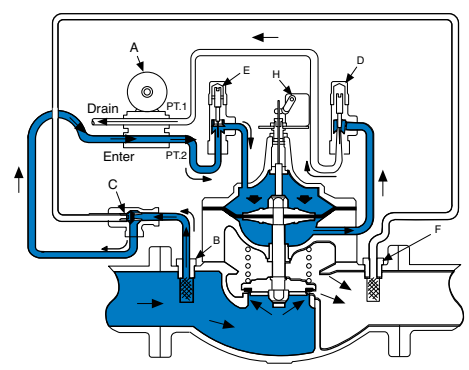

Stopping Cycle...

Starting switch opens, solenoid control de-energizes.

Upstream fluid flows to valve diagram through strainer B, shuttle valve C, solenoid control A and opening rate Flow Control E.

Valve closes slowly as fluid below diaphragm chamber is gradually released to atmosphere through closing rate flow control D and solenoid control A.

Model 60-08 Flow Chart Uses Basic Valve Model 100-03)

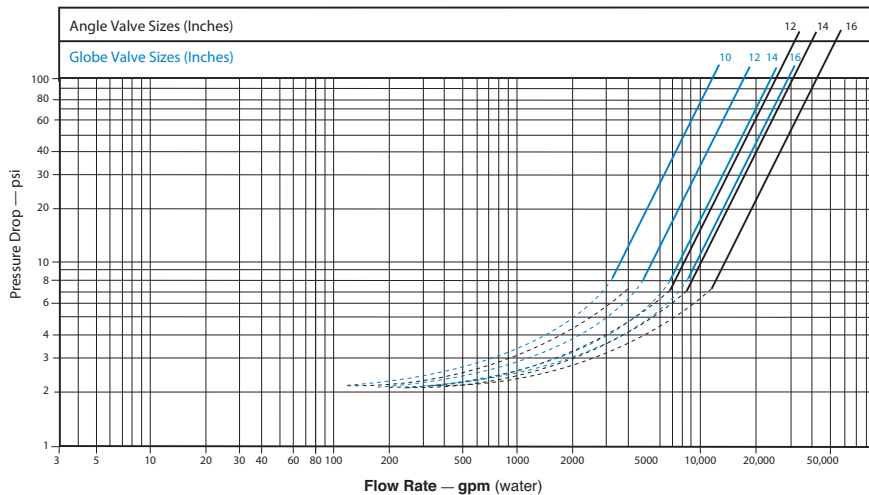

Liquid Volume Displaced from Diaphragm Chamber When Valve Opens or Closes							
Sizes (Inches)	10"	12"	14"	16"	18"	20"	24"
60-08 Displacement	2.51 gal	4.00 gal	6.50 gal	9.57 gal	----	----	----
660-08 Displacement	1.26 gal	2.51 gal	4.00 gal	6.50 gal	9.57 gal	9.57 gal	9.57 gal

Model 660-08 Flow Chart Uses Basic Valve Model 100-22)

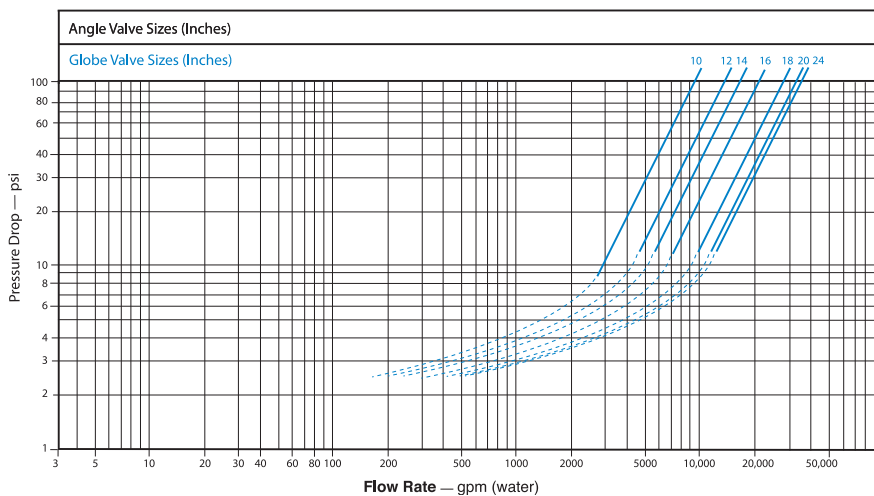

Valve Sizing

Sizing Model 60-08 or 660-08 Booster Pump Control Valves is similar to sizing non-modulating type valves. Simply select the smallest size valve that will handle the pump output at an acceptable head loss for the application.

Do not oversize. Oversizing a Booster Pump Control Valve will nullify its ability to prevent surges caused by the starting and/or stopping of the pump. Maximum flow values are given in the selection table above. For further information on flow characteristics of these valves, see the 100-03 (60-08) or 100-22 (660-08) technical data sheets in the main valve section of catalog.

Example:

A booster pump station with a rated output of 1000 GPM and 5 psi is an acceptable head loss for the application. The flow chart for the 100-22 (660-08) indicates that a 10" globe valve has less than a 5 psi pressure drop at 1000 GPM.

Drain Provisions

Each time the valve opens or closes, water is discharged from the solenoid exhaust port, the amount varying with the valve size. Provisions should be made for the disposal of this water. Exhaust tube must be free of any back pressure. Provide an air gap between the solenoid exhaust tube and drain facility.

Cla-Val offers the most complete line of automatic control valves for virtually any type of pump control system available. Please call your Cla-Val regional office or sales agent for complete design assistance. Our goal is to provide the best automatic control valve solution for each application.

Pressure Ratings (Recommended Maximum Pressure - psi)

Valve Body & Cover		Pressure Class			
		Flanged			Threaded
Grade	Material	ANSI Standards*	150 Class	300 Class	End† Details
ASTM A536	Ductile Iron	B16.42	250	640	400
ASTM A216-WCB	Cast Steel	B16.5	285	720	400
ASTM B62	Bronze	B16.24	225	500	400

Note: * ANSI standards are for flange dimensions only.
 Flanged valves are available faced but not drilled.
 † End Details machined to ANSI B2.1 specifications.

Valves for higher pressure are available; consult factory for details

Materials

Component	Standard Material Combinations		
Body & Cover	Ductile Iron	Cast Steel	Bronze
100-03 Available Sizes	10" - 16"	10" - 16"	10" - 16"
100-22 Available Sizes	10" - 24"	10" - 16"	10" - 16"
Disc Retainer & Diaphragm Washer	Cast Iron	Cast Steel	Bronze
Trim: Disc Guide, Seat & Cover Bearing	Bronze is Standard Stainless Steel is Optional		
Disc	Buna-N® Rubber		
Diaphragm	Nylon Reinforced Buna-N® Rubber		
Stem, Nut & Spring	Stainless Steel		

For material options not listed, consult factory.
 Cla-Val manufactures valves in more than 50 different alloys.

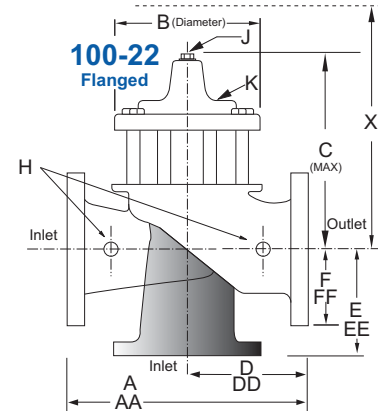
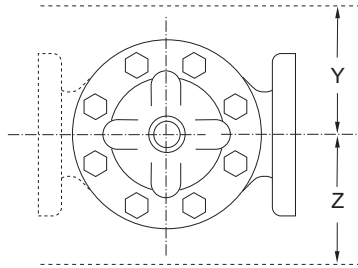
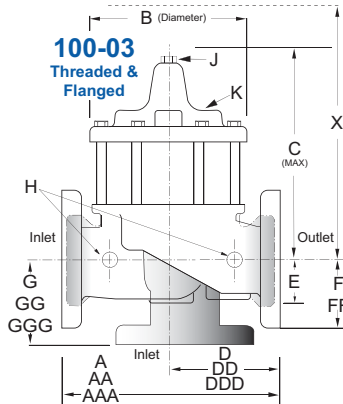

60 Series DIMENSIONS (Full Internal Port) (In Inches)

Valve Size (Inches)	10	12	14	16
A Threaded	—	—	—	—
AA 150 ANSI	29.75	34.00	39.00	41.38
AAA 300 ANSI	31.12	35.50	40.50	43.50
B Dia.	23.62	28.00	32.75	35.50
C Max.	23.38	29.31	32.12	35.00
D Threaded	—	—	—	—
DD 150 ANSI	14.88	17.00	19.50	20.69
DDD 300 ANSI	15.56	17.75	20.25	21.75
E	9.25	10.75	12.62	15.50
F 150 ANSI	8.00	9.50	10.50	11.75
FF 300 ANSI	8.75	10.25	11.50	12.75
G Threaded	—	—	—	—
GG 150 ANSI	8.62	13.75	14.88	15.69
GGG 300 ANSI	9.31	14.50	15.62	16.50
H NPT Body Tapping	1	1	1	1
J NPT Cover Center Plug	1	1.25	1.50	2
K NPT Cover Tapping	1	1	1	1
Stem Travel	2.8	3.4	4.0	4.5
Approx. Ship Wt. Lbs.	940	1675	2460	3100
X Pilot System	30.00	37.00	41.00	43.00
Y Pilot System	20.00	22.00	24.00	26.00
Z Pilot System	20.00	22.00	24.00	26.00

660 Series DIMENSIONS (Reduced Internal Port) (In Inches)

Valve Size (Inches)	10	12	14	16	18	20	24
A 150 ANSI	26.00	30.00	34.25	35.00	42.12	48.00	48.00
AA 300 ANSI	27.38	31.50	35.75	36.62	43.62	49.62	49.75
B Dia.	20.00	23.62	28.00	28.00	35.44	35.44	35.44
C Max.	23.75	27.25	29.31	34.12	35.00	40.25	40.25
D 150 ANSI	—	—	—	—	—	—	—
DD 300 ANSI	—	—	—	—	—	—	—
E 150 ANSI	—	—	—	—	—	—	—
EE 300 ANSI	—	—	—	—	—	—	—
F 150 ANSI	8.00	9.50	11.00	11.75	15.88	14.56	17.00
FF 300 ANSI	8.75	10.25	—	12.75	15.88	16.06	19.00
H NPT Body Tapping	1	1	1	1	1	1	1
J NPT Cover Center Plug	1	1	1.25	1.25	2	2	2
K NPT Cover Tapping	1	1	1	1	1	1	1
Stem Travel	2.3	2.8	3.4	3.4	4.5	4.5	4.5
Approx. Ship Wt. Lbs.	785	1410	2215	2215	2300	3400	3600
X Pilot System	36.00	39.00	43.00	45.00	50.00	50.00	55.00
Y Pilot System	20.00	22.00	24.00	26.00	26.00	30.00	30.00
Z Pilot System	20.00	22.00	24.00	26.00	26.00	30.00	30.00

60-08 Valve Selection	100-03 Pattern: Globe (G), Angle (A), End Connections: Threaded (T), Flanged (F) Indicate Available Sizes				
	Inches	10	12	14	16
	mm	250	300	350	400
Basic Valve 100-03	Pattern	G, A	G, A	G, A	G, A
	End Detail	F	F	F	F
Suggested Flow (gpm)	Maximum	4900	7000	8400	11000
	Maximum Intermittent	6150	8720	10540	13700
Suggested Flow (Liters/Sec)	Maximum	309	442	530	694
	Maximum Intermittent	387	549	664	863

100-03 Series is the full internal port Powercheck

660-08 Valve Selection	100-22 Pattern: Globe (G), Angle (A), End Connections: Flanged (F) Indicate Available Sizes							
	Inches	10	12	14	16	18	20	24
	mm	250	300	350	400	450	500	600
Basic Valve 100-22	Pattern	G	G	G	G	G	G	G
	End Detail	F	F	F	F	F	F	F
Suggested Flow (gpm)	Maximum	4100	6400	9230	9230	16500	16500	16500
	Maximum Intermittent	258	403	581	581	1040	1040	1040

100-22 Series is the reduced internal port size version of the 100-03 Series.

Pilot System Specifications

Temperature Range

Water to 180°F Max

Materials

Standard Pilot System Materials

Pilot Control: Bronze ASTM B62

Trim: Stainless Steel
Type 303

Rubber: Buna-N® Synthetic
Rubber

Optional Pilot System Materials

Pilot Systems are available with
optional Aluminum, Stainless Steel
or Monel materials.

CS4SM Solenoid Control

Enclosure:

NEMA Type 1,2,3,3S,4,4X
general purpose watertight
and NEMA Type 6,6P,7,9 water
tight and explosion proof.

Voltages:

120 - 60Hz AC

110 - 50Hz AC

Max. operating pressure
differential: 500 psi

Coil:

Continuous duty molded Class F
Watts AC 20.1
AC Volt Amps Inrush 93
AC Volt Amps Holding 40

Manual operator standard

Temperature:

Ambient 32° F to 125° F

Approvals:

CSA certified

For DC Voltages Consult Factory.

Wiring Diagram

Auto-Off-Hand = Selector Switch

1CR = Relay, DPST Normally Open

2CR = Relay, DPST Normally Open

3CR = Relay, TPST Normally Open

SW₁ = Switch, Remote Start, Automatic

SW₂ = Switch, SPDT, Valve Limit Switch
Connect to N.C. Terminal

PVS = Pilot Valve Solenoid

M = Pump Motor Starter

Note: SW₂ and PVS supplied by Cla-Val. All other electrical
items supplied by customer. SW₂ is included in the X105L switch
assembly which is mounted on the pump control valve cover.

Shown In Pump Off Position

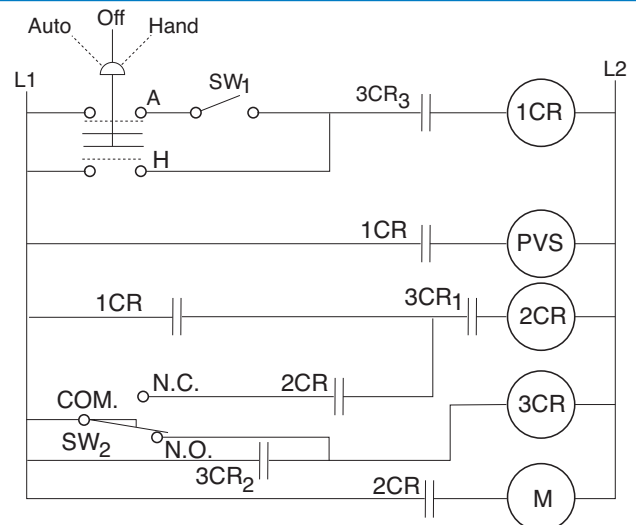

When Ordering, Please Specify:

1. Catalog No. 60-08/660-08
2. Valve Size
3. Pattern -Globe or Angle
4. Pressure Class
5. Trim Material
6. Electrical Selection
7. Desired Options
8. When Vertically Installed (Flow Direction)

CLA-VAL

P.O. Box 1325 • Newport Beach, CA 92659-0325 • Phone: 949-722-4800 • Fax: 949-548-5441 • E-mail: claval@cla-val.com • Website cla-val.com
© Copyright Cla-Val 2013 Printed in USA Specifications subject to change without notice. E-60-08/660-08 (R-1/2013)