

■ Power Switching & Controls
for Business-Critical Continuity

ASCO 7000 SERIES Power Transfer Switches



ASCO®

EMERSON™
Network Power



Critical Loads Demand ASCO

ASCO 7000 SERIES Power Transfer Switches

Protecting:

- Healthcare Facilities
- Web Hosting, Internet Data Centers
- Commercial Buildings / Industrial Buildings
- Telecom Central Offices
- Process Manufacturing
- Distributed Power / Load Management

As we become more dependent on the quality and reliability of electrical power, interruption or complete loss of power can create serious and even crippling financial losses, or impose dangers to life and safety.

ASCO Power Technologies (ASCO) provides the solutions to handle the transfer of critical loads to emergency sources reliably and with state of the art products. Using ASCO products can mean the difference between a minor inconvenience and a major catastrophe. You'll find ASCO Power Transfer Switches wherever there is a critical load to be protected.

When flexibility in power switching is a must, ASCO offers a variety of product solutions to meet virtually every application requirement, including distributed generation applications. That's why the 7000 SERIES is available in open, delayed, closed and closed soft load configurations. Additionally, switched or overlapping neutral options provide for reliable operation of ground fault protection systems and reduction of voltage transients from unbalanced load switching.

ASCO Power Transfer Switches are the first CE Marked, IEC 60947-6-1 compliant Transfer Switches in the world.



The Recognized Leader in Power Transfer Switch Technology Offers the Most Advanced Transfer Switches in the World.

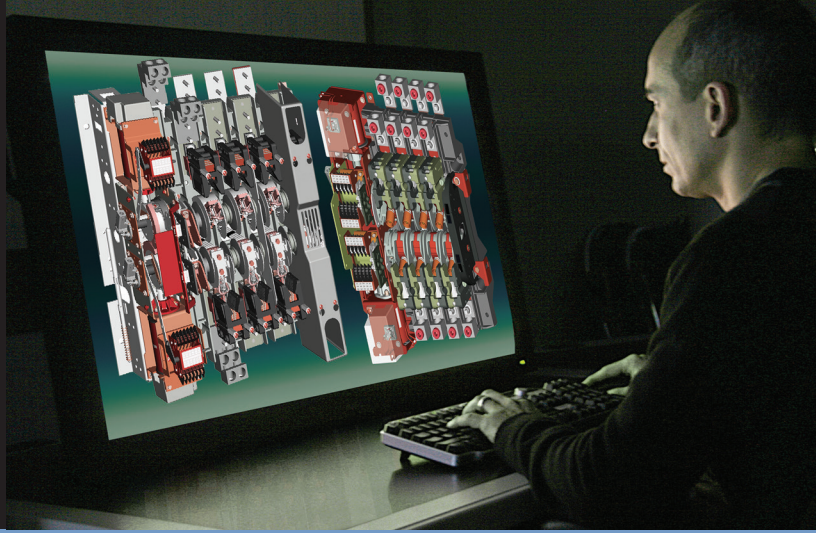

Fig. 1: Three Pole 7000 SERIES Automatic Transfer Switch rated 1600 Amperes (shown with optional front connected terminals and Power Manager).

7000 SERIES

ASCO Power Transfer Switches are the standard of the industry. High speed transfer of loads between alternate sources of power, regardless of ampacity size, is achieved by a reliable, field proven solenoid operating mechanism. When combined with a programmable microprocessor controller with keypad and LCD display, they offer the most advanced method of transferring all types of loads, such as motors, electronic drives, UPS's and microprocessor based systems. 7000 SERIES Power Transfer Switches are available open or enclosed, in ampacity sizes from 30 through 4000 Amperes with the largest selection of optional accessories offered anywhere. All switching configurations are available with an integrally mounted bypass-isolation switch and/or rated for use in service entrance applications.

7000 SERIES Power Transfer Switches Product Features

- Conventional two-position transfer configuration, plus closed and delayed transition modes of operation. All configurations available with either automatic or non-automatic control.
- UL listed to 1008 Transfer Switch Equipment & CSA certified to CSA 22.2 No. 178-1978 Automatic Transfer Switches.
- Qualified and certified to IEC 60947-6-1, CE marked (optional). (Limited to certain accessories.)
- Rated up to 600 VAC, 30 through 4000 Amperes.
- Reliable and field proven solenoid operating mechanism.
- High withstand and close-on ratings including short time withstand current rating for optimum flexibility in circuit breaker coordination (600-4000 Amperes).
- Solid, switched, or overlapping neutral conductor options.
- Front replaceable main and arcing contacts (800-4000 Amperes).
- Programmable microprocessor controller with keypad and LCD display.
- Centrally located terminal block for customer control connections (260-4000 Amperes).
- 16mm, industrial grade control switches and indicating lights.
- Switch position LED indicators and source acceptability lights.
- Standard ground conductor connections.
- Four auxiliary contacts, two contacts closed when switch is in normal position and two contacts closed when switch is in emergency position.
- Local/remote communications capability for interfacing with ASCO POWERQUEST® communication products.
- Protected by a comprehensive warranty.



Fig. 2: Four pole, Closed Transition Transfer Switch rated 1000 Amperes in Type 1 enclosure.

Delayed Transition Transfer Switching

ASCO Delayed Transition Transfer Switches are designed to provide transfer of loads between power sources with a timed load disconnect position for an adjustable period of time. Applications include older style variable frequency drives, rectifier banks, and load management applications.

- Available in 150 through 4000 Amperes.
- Utilizes reliable, field proven solenoid operating mechanisms.
- Mechanical interlocks to prevent direct connection of both sources.
- Indicator light (16mm, industrial grade type LED) for load disconnect position.
- Adjustable time delay for load disconnect position.

Closed Transition Transfer Switching

ASCO Automatic Closed Transition Transfer Switches feature main contacts that overlap, permitting the transfer of electrical loads without power interruption. The switch transfers in a make-before-break mode if both sources are within acceptable parameters. Control logic continuously monitors source conditions and automatically determines whether the load transfer should be open (conventional non-overlap mode) or closed transition. Available 150 through 4000 Amperes.

Closed Transition Transfer within 5 electrical degrees is achieved passively, without control of engine generator set. Therefore, no additional control wire runs are required between the ATS and engine generator set governor. Plus, protective relaying may not be required under normal operation since the contact overlap time is less than 100 milliseconds (consult your local utility on protective relay requirements).

Failure to synchronize indication and extended parallel time protection is built-in to all 7000 SERIES closed transition controls to prevent abnormal operation.



Fig. 3: Four pole, Delayed Transition Transfer Switch rated 2000 Amperes.

Non-Automatic Transfer Switching

ASCO Non-Automatic Transfer Switches are electrically operated units which are operated with manual control switches mounted locally or at remote locations.

- Sizes from 30 through 4000 Amperes.
- Microprocessor based controller provides for addition of optional accessories.
- Controller prevents inadvertent operation under low voltage conditions.
- Low control circuit operating currents allow for long line runs between remotely mounted manual control switches and the transfer switch.
- Source acceptability lights inform operator if sources are available to accept load.
- Standard inphase monitor can be activated for transferring motor loads.



Fig. 4: Three pole Non-Automatic, electrically operated 400 ampere switch shown in Type 1 enclosure.

Withstand and Close-On Ratings for all 7000 SERIES Products^{1,2} (RMS Symmetrical Amps)

| Frame | Switch Rating (Amps) | | Current Limiting Fuses | | | | Specific Breaker | | | Time Based | | | Short Time Ratings ³ (sec) | | | | | | |
|-------|---|---|------------------------|-------|----------|-------|--------------------|--------------------|--------------------|------------|--------------------|--------------------|---------------------------------------|-----------|------|-------|-----------|------|------|
| | Transfer Switches | Bypass Switches | 480V | 600V | Max Size | Class | 240V | 480V | 600V | Time | 240V | 480V | 600V | 480V Max. | | | 600V Max. | | |
| | | | | | | | | | | | | | | .1 | .13 | .3 | .5 | .1 | .13 |
| D | 30 | - | 100kA | - | 60 | J | 22kA | 22kA | 10kA | 0.025 | 10kA | 10kA | 10kA | - | - | - | - | - | - |
| D | 70, 100 | - | 35kA | 35kA | 200 | RK1 | 42kA | 22kA | 10kA | 0.025 | 10kA | 10kA | 10kA | - | - | - | - | - | - |
| | | | 200kA | 35kA | 200 | J | | | | | | | | | | | | | |
| D | 150 | - | 35kA | 35kA | 200 | RK1 | 65kA | 25kA | 10kA | 0.025 | 10kA | 10kA | 10kA | - | - | - | - | - | - |
| | | | 200kA | 35kA | 200 | J | | | | | | | | | | | | | |
| D | 200 | - | 200kA | - | 200 | J | 65kA | 25kA | - | 0.025 | 10kA | 10kA | - | - | - | - | - | - | - |
| D | 230 | - | 100kA | - | 300 | J | 65kA | 25kA | - | 0.025 | 10kA | 10kA | - | - | - | - | - | - | - |
| E | 260, 400 | - | 200kA | - | 600 | J | 65kA | 42kA | 35kA | 0.05 | 35kA | 35kA | 22kA | - | - | - | - | - | - |
| J | 150 ⁷ , 200 ⁷ , 230 ⁷ , 260, 400 | 150 ⁷ , 200 ⁷ , 230 ⁷ , 260, 400 | 200kA | 200kA | 600 | J | 50kA | 50kA | 42kA | 0.05 | 65kA | 42kA ⁸ | 35kA | - | - | - | - | - | - |
| J | 600 | 600 | 200kA | 200kA | 800 | L | 50kA | 50kA | 42kA | 0.05 | 65kA | 42kA ⁸ | 35kA | - | - | - | - | - | - |
| H | 600 | 600 | 200kA | 200kA | 800 | L | 65kA | 65kA | 65kA | 0.05 | 50kA | 50kA | 50kA | 36kA | - | 36kA | - | - | - |
| P | 600 | 600 | 200kA | 200kA | 800 | L | 65kA | 65kA | 65kA | 0.05 | 50kA | 50kA | 50kA | 36kA | 30kA | 36kA | - | - | - |
| P | 800 | 800 - 1200 | 200kA | 200kA | 1600 | L | 65kA | 65kA | 65kA | 0.05 | 50kA | 50kA | 50kA | 36kA | 30kA | 36kA | - | - | - |
| H | 800 - 1200 | 800 - 1200 | 200kA | 200kA | 1600 | L | 65kA | 65kA | 65kA | 0.05 | 50kA | 50kA | 50kA | 36kA | - | 36kA | - | - | - |
| Q | 600-1600 | 600-1600 | 200kA | 200kA | 2000 | L | 65kA | 65kA | 65kA | 0.05 | 65kA | 65kA | 65kA | 50kA | - | 50kA | - | - | - |
| S | 800 - 1200 | 800 - 1200 | 200kA | 200kA | 2500 | L | 100kA | 100kA | 65kA | 0.05 | 100kA | 100kA | 65kA | 65kA | - | 65kA | - | - | - |
| G | 1000 - 1200 | 1000 - 1200 | 200kA | 200kA | 2000 | L | 85kA | 85kA | 85kA | 0.05 | 85kA | 85kA | 85kA | - | - | - | - | - | - |
| G | 1600 - 2000 ⁹ | - | 200kA | 200kA | 2500 | L | 85kA ⁴ | 85kA ⁴ | 85kA ⁴ | 0.05 | 85kA ⁴ | 85kA ⁴ | 85kA ⁴ | - | - | - | - | - | - |
| G | 1600 - 2000 | 1600 - 2000 | 200kA | 200kA | 3000 | L | 125kA ⁸ | 125kA ⁸ | 100kA | 0.05 | 100kA | 100kA | 100kA | 42kA | - | 42kA | - | - | - |
| S | 1600 - 2000 | 1600 - 2000 | 200kA | 200kA | 2500 | L | 100kA | 100kA | 85kA | 0.05 | 100kA | 100kA | 85kA | 85kA | 65kA | 85kA | 65kA | 85kA | 65kA |
| G | 2600 - 3000 | 2600 - 3000 | 200kA | 200kA | 4000 | L | 100kA | 100kA | 100kA | 0.05 | 100kA | 100kA | 100kA | 42kA | - | 42kA | 6 | 42kA | 6 |
| G | 3200 | - | 200kA | - | 4000 | L | 100kA | 100kA | - | 0.05 | 100kA | 100kA | - | - | - | - | - | - | - |
| G | 4000 | 4000 | 200kA | 200kA | 5000 | L | 100kA | 100kA | 100kA | 0.05 | 100kA | 100kA | 100kA | 85kA | 65kA | 85kA | 65kA | 85kA | 65kA |
| U | 2600 - 4000 | 2600 - 4000 | 200kA | 200kA | 5000 | L | 125kA ⁹ | 125kA ⁹ | 125kA ⁹ | 0.06 | 125kA ⁹ | 125kA ⁹ | 125kA ⁹ | 100kA | - | 100kA | - | - | - |

Notes: 1) All WCR values indicated are tested in accordance with the requirements of UL 1008, 7th Edition. See ASCO Pub. 1128 for more WCR information
 2) Application requirements may permit higher WCR for certain switch sizes.
 3) Short Time ratings are provided for applications involving circuit breakers that utilize trip delay settings for system selective coordination
 4) Optional front connected service (Accy 40MY and 40NY) limits WCR on 1600 and 2000A G Frame switches
 5) Switches utilizing overlapping neutral (code "C") have 35kA, 0.050 Sec time based rating at 480V Max
 6) 3000A ratings are for Transfer Switch configurations only
 7) J150, 200, 230 Amp available in 7ACTS, 7ADTS, 7ASLS, & All 7000 Bypass Switches only
 8) Rating shown is for Bypass switches only, Transfer Switch rating is 100kA
 9) Service Entrance Switches rating is 100kA

Automatic Transfer Bypass-Isolation Switches



Fig. 5: Rated 150-600 Amps



Fig. 6: Rated 600-1200 Amps



Fig. 7: Rated 800-3000 Amps



Fig. 8: Rated 4000 Amps

ASCO Automatic Transfer & Bypass-Isolation Switches are available in open transition, closed transition and delayed transition designs. The bypass and isolation features allow the primary automatic transfer switch to be inspected, tested, and maintained without any interruption of power to the load. They also provide redundant power transfer in the event the ATS is disabled or removed from service.

- Available 150 to 4000 Amperes.
- Allows bypass-isolation without load interruption.
- Bypass switch and transfer switch have identical electrical ratings.
- Heavy duty mechanical interlocks prevent undesirable operation.
- Bypass contacts carry current only during bypass mode.
- Transfer switch is drawout design for ease of maintenance.
- Bypass and isolation handles are permanently mounted. The bypass switch has dead front quick-make, quick-break operation for transferring of loads between live sources.
- Bypass switch is fully rated for use as a manual 3-position transfer switch.
- Bypass and isolation functions are simple, requiring a total of two operating handles.
- No toggle switches, push buttons, selector switches or levers are required for bypass-isolation operation.
- Mechanical indicators show bypass and transfer switch positions.
- 800 -1200 ampere available in shallow depth, front connected or rear connected designs.

Transfer Switch Drawout Features (150-4000 Amperes)

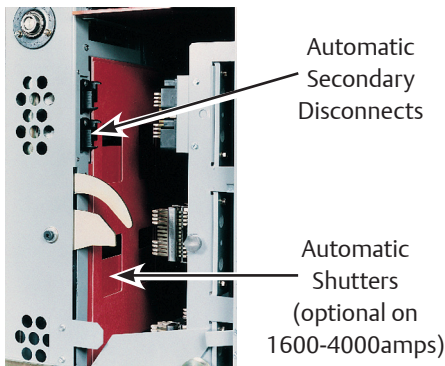

Fig. 9: Bypass-Isolation Transfer Switch secondary disconnects and optional automatic shutters.

- Automatic secondary disconnects remove all control power as switch is withdrawn.
- Drawout carriage provides for easy transfer switch maintenance and/or removal via commercially available breaker hoists.
- Optional transfer switch lifting yoke kit available
- Optional automatic shutters which close when the transfer switch is withdrawn to provide bus isolation, specify accessory 82C.(1600-4000A only)

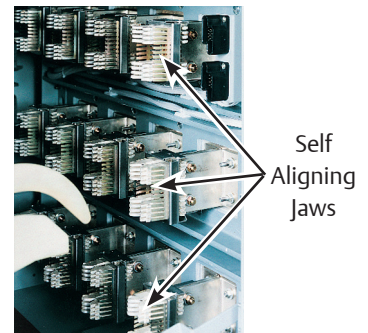

Fig. 10: Bypass-Isolation Transfer Switch self aligning power jaws.

ASCO® 7000 SERIES Power Switching Solutions

Bypass and Isolation Handles - Simple as 1, 2, 3

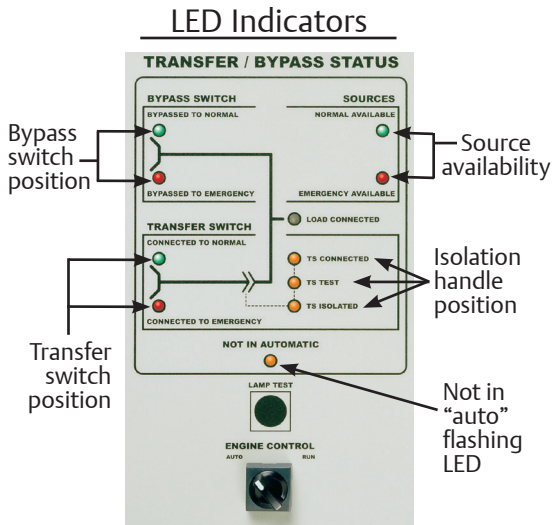
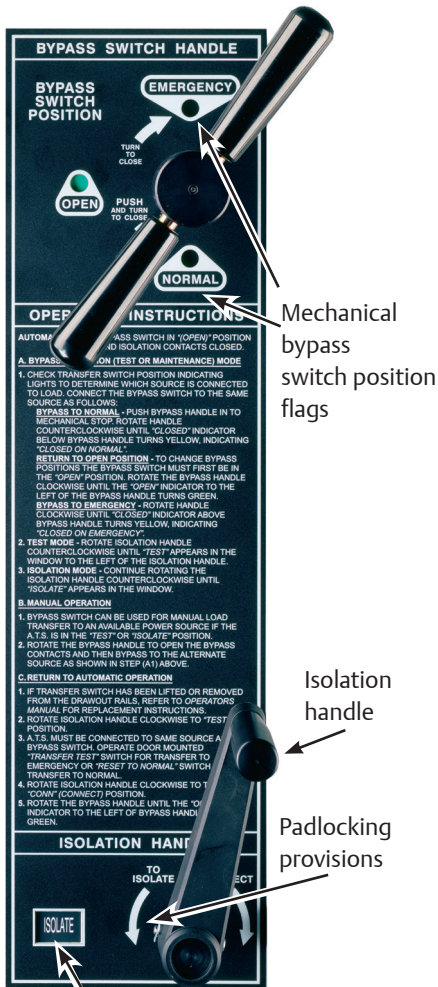

Fig. 11: Transfer Bypass Status Panel*

*Standard on switches up through H 1200A. Specify ACC 82E for G frame 1600-4000A



Mechanical isolation handle position window (connected/test/isolate)

Fig. 12: Bypass-Isolation Switch user interface

1 Bypass to Normal

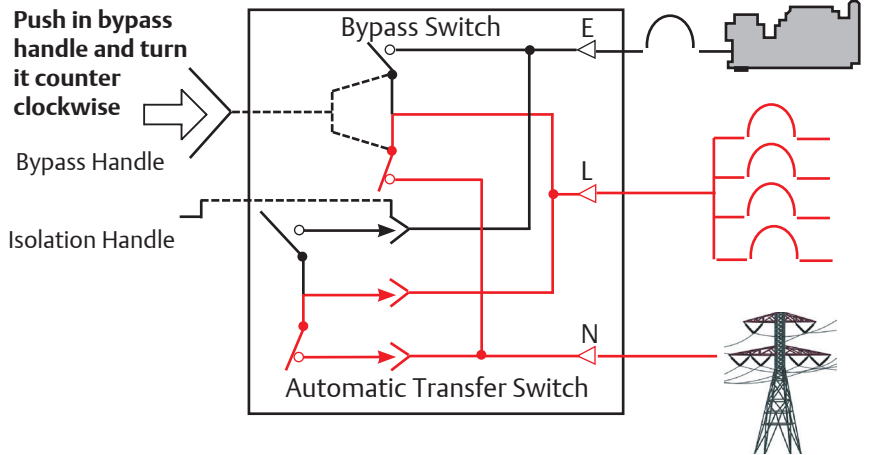

2 Test Position

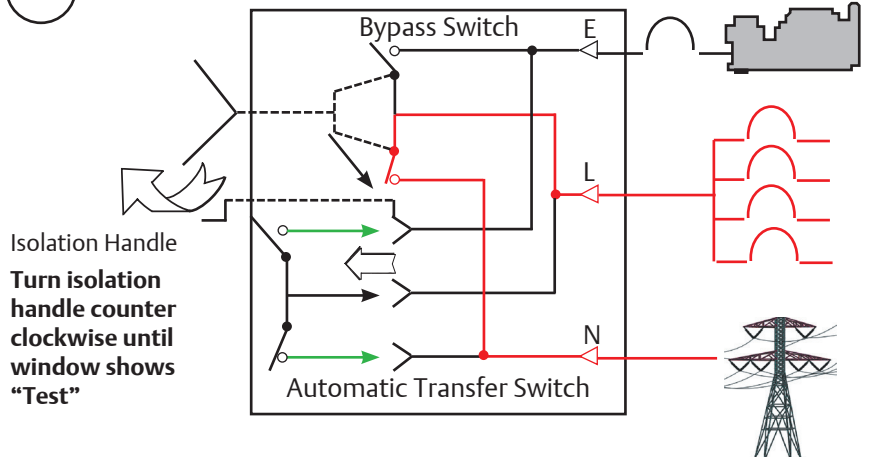

3 Isolation Position

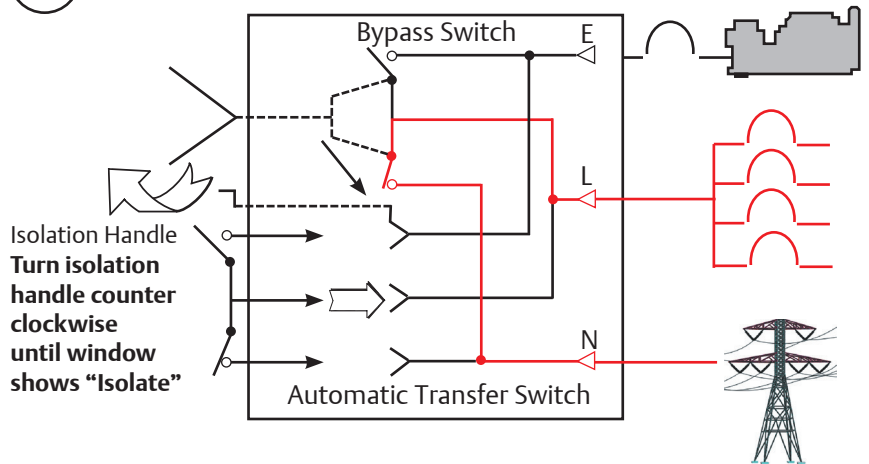

Key:

- Represents Current Flow
- In test position control panel remains energized to allow for electrical operation of a transfer switch.

ASCO® 7000 SERIES Service Entrance Power Transfer Switches

The ASCO Service Entrance Power Transfer Switch combines automatic power switching with a disconnect and overcurrent protective device on the utility source. The power transfer switch meets all National Electric Code requirements for installation at a facility's main utility service entrance. Service entrance rated transfer switches generally are installed at facilities that have a single utility feed and a single emergency power source. A circuit breaker serves as the utility disconnect and links are provided to dis-connect both neutral and ground connections.

This product is either UL 1008 or UL 891 listed and is available up to 600V and 4000A in Standard, Delayed, Closed Transition, Soft Load, and Bypass Isolation Configurations.

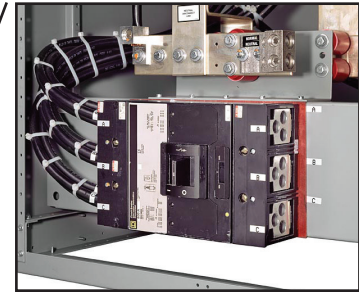
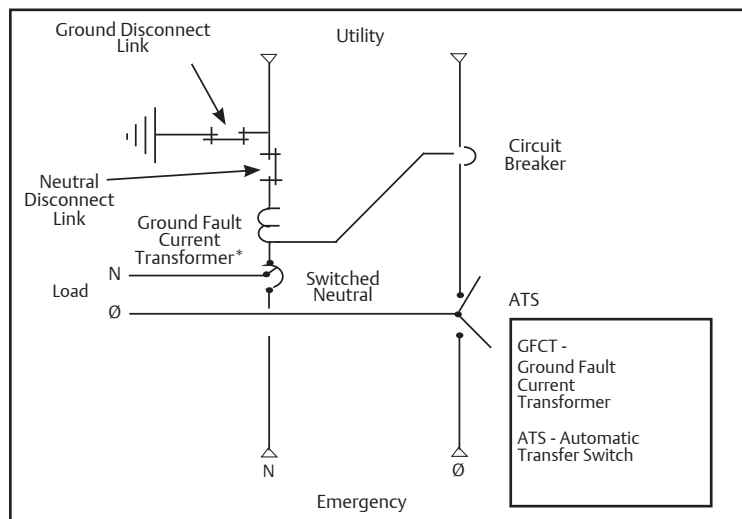

Fig. 13: Ground and neutral disconnect links

Standard Features

- Available from 150 to 4000 Amperes
- ASCO 7000 SERIES Power Transfer Switch is UL 1008 Listed
- Standard UL Type 1 Enclosure
- Disconnect and overcurrent protective device on the utility source: molded case circuit breaker 150 to 2000 Amp; insulated case 3000 to 4000 Amp
- Disconnect link on Neutral
- Disconnect link on Ground
- Ground and Neutral Bus, all silver-plated copper
- Solderless screw type terminals for External Power Connections
- Meets all NEC requirements for use as service entrance
- Internet enabled monitoring and control
- Service entrance breakers are rated: - 100% for 1000 Amps and above; 80% below 1000 Amps for all bypass switches - 100% for 2500 Amps and above; 80% below 2500 Amps for all standard transfer switches



One line diagram of a typical service entrance rated transfer switch available in Solid, Switched or Overlapping Neutral

* Ground fault trip protection provided on sizes of 1000 Amperes and above

Optional Features

- Enclosures - Secure Double Door
 - UL Type 3R w/strip heater & thermostat
 - UL Type 4 or 4X
 - UL Type 12
- Connections
 - Crimp lugs
 - Bus Riser on Normal, Emergency or Load
- Protective Relays/Metering
 - Accessory 85L, see page 15
- Surge Suppression
 - Accessory 73, Surge protector (see pg. 14)
- ASCO POWERQUEST® products (see pages 16-21)
 - ASCO 72E Ethernet Connectivity module, page 17
 - ASCO 5310/5350 Remote annunciators, page 17
 - ASCO 5400 Power Quality Meters, page 17
- Additional Breaker(s)
 - Circuit Breaker on Emergency
 - Load Distribution Panel
- Optional high AIC ratings on breakers

Consult ASCO for additional features

ASCO® 7000 SERIES Service Entrance Power Transfer Switches

Ordering Information

To order an ASCO 7000 SERIES Service Entrance Power Transfer Switch, complete the following catalog number.

7 A US + A + 3 + 400 + N + 5X + C

| | Product | Neutral Code* | Phase Poles | Amperes | Voltage Code | Grp Code | Enclosure |
|---|---------------|-------------------------------|----------------------------|-------------|--------------|---------------------------------------|------------------------------|
| A | Automatic | US Conventional 2-Position | A Solid Neutral (standard) | 2 | 70, 100 | C 208 | C Type 1 enclosure |
| N | Non-Automatic | UB Open Transition Bypass | B Switched Neutral | 3 | 150, 200 | D 220 | M Type 3R secure double door |
| | | CUS Closed Transition | C Overlapping Neutral | 225, 250 | E 230 | N Type 4 secure double door | |
| | | CUB Closed Transition Bypass | | 400, 600 | F 240 | P Type 4X secure double door (316 SS) | |
| | | DUS Delayed Transition | | 800, 1000 | H 380 | Q Type 12 secure double door | |
| | | DUB Delayed Transition Bypass | | 1200, 1600, | J 400 | S Type 4X secure double door (304 SS) | |
| | | | | 2000, 2500, | K 415 | | |
| | | 3000 | L 440 | | | | |
| | | 4000 | M 460 | | | | |
| | | | N 480 | | | | |
| | | | P 550 | | | | |
| | | | Q 575 | | | | |
| | | | R 600 | | | | |

*Note: Switches rated 150-4000 amps available with 2, 3 or either conventional switched neutral 4 pole (B3) or optional overlapping neutral (C3). For 4 pole applications on E7AUS, and E7NUS switch sizes 250 and 400 amps specify optional overlapping neutral (C3).

The Example Catalog Number above is 7AUSA3400N5XC (X is used to specify optional accessories).

Dimensions and Weights for non-bypass configurations

Type 1 and 3R Enclosures⁴

| Frame | Switch Amp Ratings | Type 1 Dimensions, In. (mm) | | | Approx. Shipping Weight Lb. (kg) |
|-------|---|-----------------------------|-------------|-------------|----------------------------------|
| | | Width | Height | Depth | |
| D | 70, 100, 150, 200, 225 7AUS/7NUS Only | 36.5 (927) | 48.5 (1232) | 13.25 (337) | 490 (226) |
| J | 250, 400 | 38 (965) | 91 (2311) | 28 (711) | 880 (407) |
| J | 150, 200, 225 7ADUS/7NDUS and 7ACUS/7NCUS only | 38 (965) | 91 (2311) | 28 (711) | 880 (407) |
| J | 600 ¹ | 38 (965) | 91 (2311) | 28 (711) | 980 (452) |
| H | 800 ¹ | 38 (965) | 91 (2311) | 28 (711) | 1280 (590) |
| H | 1000 ¹ | 38 (965) | 91 (2311) | 48 (1219) | 1280 (590) |
| H | 1200 ¹ | 38 (965) | 91 (2311) | 48 (1219) | 1480 (683) |
| G | 1600 ¹ , 2000 ¹ | 38 (965) | 91 (2311) | 48 (1219) | 2890 (1333) |
| G | 2500 ¹ , 3000 ¹ | 38 (965) | 91 (2311) | 72 (1829) | 5200 (2400) |

System Short Circuit Rating

7AUS/7ACUS/7ADUS

| Switch Amp Ratings | @480V |
|--------------------|---------|
| 70 - 225 | 22,000 |
| 250, 400 | 35,000 |
| 600 | 50,000 |
| 800 | 65,000 |
| 1000, 1200 | 50,000 |
| 1600, 2000 | 65,000 |
| 2500, 3000 | 100,000 |
| 4000 | 100,000 |

System Short Circuit Rating

7AUB/7ACUB/7ADUB

| Switch Amp Ratings | @480V |
|--------------------|---------|
| 150 - 400 | 35,000 |
| 600 | 50,000 |
| 800 | 65,000 |
| 1000, 1200 | 85,000 |
| 1600, 2000 | 100,000 |
| 2500, 3000 | 100,000 |
| 4000 | 100,000 |

| Frame | Switch Amp Ratings | Type 3R Dimensions, In. (mm) | | | Approx. Shipping Weight Lb. (kg) |
|-------|---|------------------------------|------------|-----------|----------------------------------|
| | | Width | Height | Depth | |
| D | 70, 100, 150, 200, 225 7AUS/7NUS Only | 36 (914) | 48 (1219) | 16 (406) | 540 (249) |
| J | 250, 400 | 41 (1041) | 95½ (2426) | 33 (838) | 1880 (544) |
| J | 150, 200, 225 7ADUS/7NDUS and 7ACUS/7NCUS only | 41 (1041) | 95½ (2426) | 33 (838) | 1880 (544) |
| J | 600 ¹ | 41 (1041) | 95½ (2426) | 33 (838) | 1280 (590) |
| H | 800 ¹ | 41 (1041) | 95½ (2426) | 33 (838) | 1480 (683) |
| H | 1000 ¹ | 41 (1041) | 95½ (2426) | 62 (1575) | 1480 (683) |
| H | 1200 ¹ | 41 (1041) | 95½ (2426) | 62 (1575) | 1940 (895) |
| G | 1600 ¹ , 2000 ¹ | 41 (1041) | 95½ (2426) | 62 (1575) | 2990 (1379) |
| G | 2500 ¹ , 3000 ¹ | 41 (1041) | 96 (2437) | 85 (2159) | 5300 (2444) |

Notes: 1. Unit is designed for top and bottom cable entry for all services and load.

2. Enclosures for 600 – 3000 amps are free standing.

3. When temperatures below 32° F can be experienced, special precautions should be taken, such as the inclusion of strip heaters, to prevent condensation and freezing of this condensation. This is particularly important when environmental enclosures (Type 3R, 4 & 12) are ordered for installation outdoors. Type 3R enclosures are not suitable for installations conducive to windblown snow or rain conditions.

4. Dimensional data is approximate and subject to change. Certified dimensions available upon request. Type 3R enclosures are not suitable for installations conducive to windblown snow or rain conditions.

5. A comprehensive ASCO Limited Guardian Warranty covers 7000 Series Power Transfer Switch(s) and warrants the product to be free of defects in material and workmanship from date of shipment. The warranty provides:

- 2 years for labor and travel expenses (extendable in 1 year increments up to 5 years for a nominal fee).
- 5 years for parts (2 years for circuit breakers).
- 10 years for main contacts.

Refer to Publication 3227 for warranty details, terms and conditions.

ASCO[®] 7000 SERIES Microprocessor Controller



Fig. 14: 7000 SERIES Microprocessor Controller.

The 7000 SERIES Microprocessor Based Controller is used with all sizes of Power Transfer Switches from 30 through 4000 Amperes. It represents the most advanced digital controller in the industry and includes, as standard, all of the voltage, frequency, control, timing and diagnostic functions required for most emergency and standby power applications.

Because of severe voltage transients frequently encountered with industrial distribution systems, the microprocessor logic board is separated and isolated from the power board as shown below. This improves electrical noise immunity performance and helps assure compliance with the rigorous transient suppression standards highlighted below.

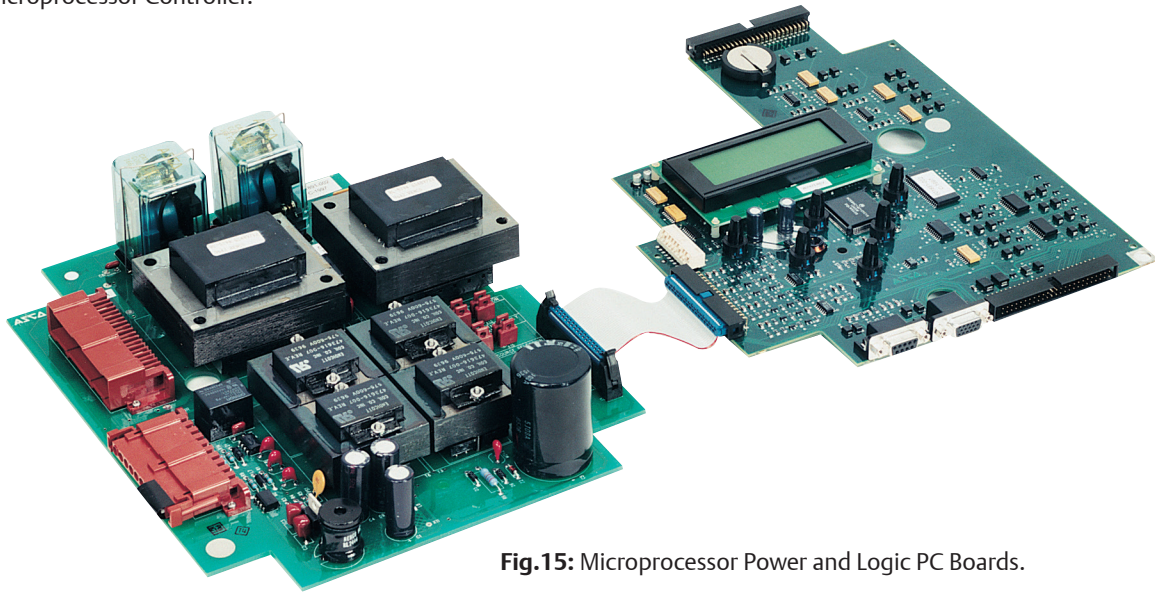

Fig.15: Microprocessor Power and Logic PC Boards.

| 7000 SERIES Microprocessor Based Controller | |
|---|--------------------|
| Emission Standard - Group 1, Class A | EN 55011:1991 |
| Generic Immunity Standard, from which: | EN 50082-2:1995 |
| Electrostatic Discharge (ESD) Immunity | EN 61000-4-2:1995 |
| Radiated Electromagnetic Field Immunity | ENV 50140:1993 |
| Electrical Fast Transient (EFT) Immunity | EN 61000-4-4:1995 |
| Surge Transient Immunity | EN 61000-4-5:1995 |
| Conducted Radio-Frequency Field Immunity | EN 61000-4-6:1996 |
| Voltage Dips, Interruptions and Variations Immunity | EN 61000-4-11:1994 |

Features

- Digital microprocessor.
- Touch pad programming of features and settings without the need for meters, or variable power supplies.
- Sixteen (16) selectable operating voltages available in a single Controller.
- On-board diagnostics provide control panel and ATS status information to analyze system performance.
- Displays and counts down active timing functions.
- Selectable multi-language display (English, German, Portuguese, Spanish, or French. For others contact ASCO).
- Password protection to prevent unauthorized tampering of settings.
- Remote monitoring and control with ASCO POWERQUEST® communications products. Specify optional accessory 72E.
- Load shed option for bus optimization applications. Specify optional accessory 30B.
- Historical event log
- Statistical ATS systems monitoring information

Voltage and Frequency Sensing

- 3-Phase under and over voltage settings on normal and emergency sources.
- Under and over frequency settings on normal and emergency.
- True RMS Voltage Sensing with +/- 1% accuracy; Frequency Sensing Accuracy is +/- 0.2%.
- Selectable settings: single or three phase voltage sensing on normal and emergency; 50 or 60Hz.
- Phase sequence sensing for phase sensitive loads.
- Voltage unbalance detection between phases.

Status and Control Features

- Output contact (N/O or N/C) for engine-start signals.
- Selection between “commit/no-commit” on transfer to emergency after engine start and normal restores before transfer.
- Advanced inphase algorithm which automatically measures the frequency difference between the two sources and initiates transfer at appropriate phase angles to minimize disturbances when transferring motor loads.
- Event log displays 99 logged events with the time and date of the event, event type and event reason.
- Output signals for remote indication of normal and emergency source acceptability
- Statistical ATS/System monitoring data screens which provide:
 - Total number of ATS transfers.
 - Number of ATS transfers caused by power source failure.
 - Total number of days ATS has been in operation.
 - Total number of hours that the normal and emergency sources have been available.

Time Delays

- Engine start time delay - delays engine starting signal to override momentary normal source outages - adjustable 0 to 6 seconds.
- Transfer to emergency time delay - adjustable 0 to 60 minutes.
- Emergency source stabilization time delay to ignore momentary transients during initial generator set loading - adjustable 0 to 6 seconds.
- Retransfer to normal time delay with two settings:
 - Power failure mode - 0 to 60 minutes.
 - Test mode - 0 to 10 hours.
- Unloaded running time delay for engine cool down - adjustable 0 to 60 minutes.
- Pre and post transfer signal time delay for selective load disconnect with a programmable bypass on source failures - adjustable 0 to 5 minutes. This signal can be used to drive a customer furnished relay, or for (2) sets of double throw contacts rated 3 amps at 480 volts AC, specify ASCO optional accessory 31Z.
- Fully programmable engine exerciser with seven independent routines to exercise the engine generator, with or without loads, on a daily, weekly, bi-weekly or monthly basis.
- Contains all alarm signals, logic and time delays for use with closed transition switches.
 - In synch time delay - 0 to 3 seconds.
 - Failure to synchronize - 1 to 5 minutes.
 - Extended parallel - 0.1 to 1.0 seconds.
- Delayed transition load disconnect time delay - adjustable 0 to 5 minutes.

Control Switches and Indicating Lights for Conventional 2-Position Switches

- Switch position indicating lights (16 mm, industrial grade LEDs).
- Source acceptability indicating lights with true indication of the acceptability of each source, as determined by the voltage, frequency, voltage unbalance, and phase sequence settings of the control panel (16mm, industrial grade LEDs).
- Three position (16mm, industrial grade type) selector switch:
- Automatic: Normal maintained position.
- Test: Momentary position to simulate normal source failure for system test function.
- Reset Delay Bypass: Momentary position to bypass transfer and re-transfer time delay.

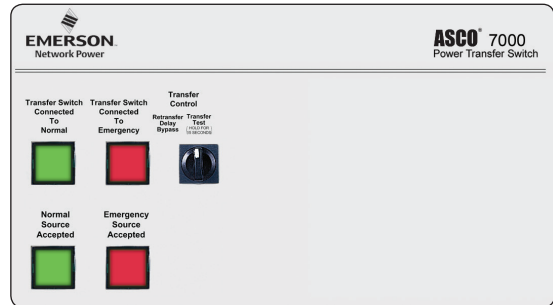

Fig. 16: 7000 SERIES User Controls and Indicators.

Control Switches and Indicating Lights for Closed Transition Switches

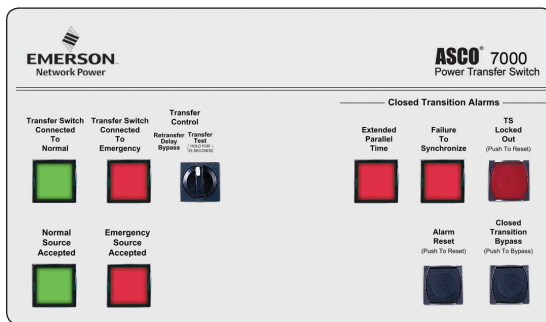

Fig. 17: 7000 SERIES User Controls and Indicators.

- Extended Parallel Time - Provides visual indication when the pre-set extended parallel time has been exceeded. The controls automatically open the emergency or normal main contacts. Separate contact also available to shunt trip external breaker.
- Failure To Synchronize - Visually displays a failure to synchronize alarm if the time delay settings is exceeded, during closed transition transfer operation.
- TS Locked Out - Prevents transfer in either direction if the extended parallel time is exceeded.
- Alarm Reset - Resets extended parallel and failure to synchronize alarms.
- Closed Transition Bypass - Pushbutton allows transfer between sources in an open transition mode.

7000 SERIES Power Control Center



Fig. 18: 7000 SERIES Power Control Center.

The 7000 SERIES microprocessor controller is a Power Control Center which allows the user to easily access detailed information on: system status; power source parameters; voltage, frequency and time delay settings; optional feature settings; historical event log; and system diagnostics. A four line, (20) character LCD has a backlit display which enables easy viewing under all conditions. The user can navigate through all screens using only six buttons, which also allows selection of: (18) different source parameter settings; (16) standard time delays; (12) standard feature settings; up to seven independent engine exercise routines; and even the language (English, German, Spanish, French, etc.) which appears on the display.

Since the Power Control Center must be visible and operable through the enclosure door, it has been qualified for use in industrial and outdoor applications. This includes installation in Type 3R (outdoor/rainproof), 4 (weatherproof) and 12 (indoor/industrial) enclosures. For applications with regular exposure to direct sunlight a double door for UV protection is recommended.

ASCO® 7000 SERIES Power Control Center Screens

Status

System Status

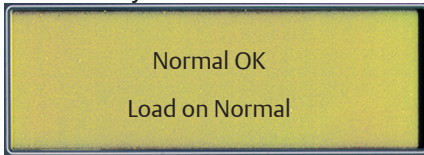

Displays system status in clear, concise language. Message shown indicates normal source is acceptable and the load is connected to the normal source.

Source Status

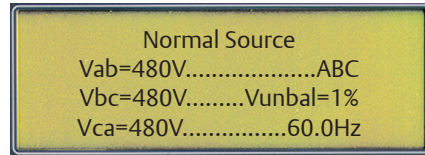

Displays voltage for each phase, frequency, phase rotation and voltage unbalance for both normal and emergency sources.

Time Delay Status

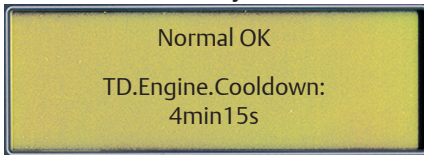

Active time delay status displays time remaining until next control event.

Inphase Transfer Mode

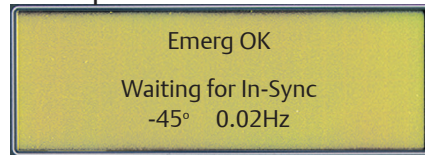

Displays the relative phase angle between sources and frequency differential to indicate the controller is awaiting an inphase condition.

Settings

Voltage and Frequency Settings

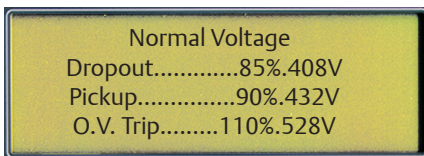

Provides voltage and frequency setting values for normal and emergency sources. Voltage pick-up, dropout and trip settings are set in percentage of nominal voltage and are also displayed in rms voltage values.

Time Delay Settings

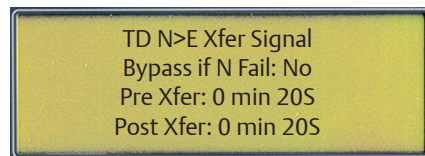

Provides direct reading display for setting time delays.

Engine Exerciser

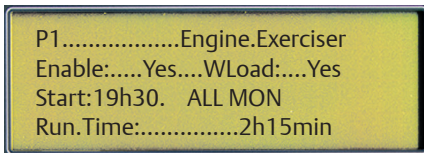

Seven independent programs, load/no load selection, flexible run times and daily, weekly, bi-weekly and monthly exercise routines.

Feature Settings

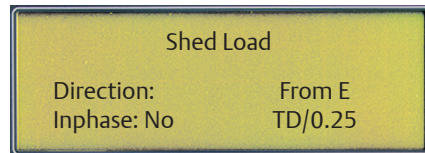

Standard features can be activated with the keypad. As an example, when enabled, the “shed load” option causes the transfer switch to transfer the load off of the specified source. If desired, the load shed transfer can be made inphase.

Data Logging

ATS Statistics

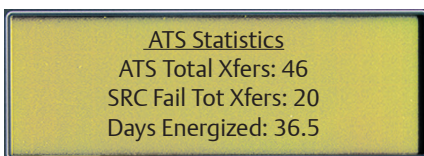

Instant availability of statistical information on total number of ATS transfers, number of transfers caused by power failures and total days controller has been energized, plus more.

Historical Event Log

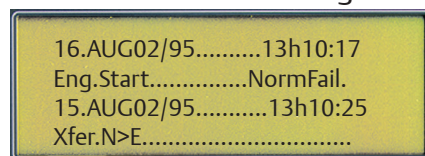

Displays detailed information for last 99 events, including time of occurrence, length of event, date and reason for event.

ASCO[®] 7000 SERIES Optional Accessories

Time Delays

- 2C Provides an extended time delay on engine starting. The standard feature one time delay is adjustable from zero to six seconds. Accessory 2C allows this time delay to be adjustable from zero to sixty minutes in one second intervals factory set at five minutes.
- 1G Similar to accessory 2C except using 24 volt DC external input signal. 7000 SERIES controller remains active when both power sources are de-energized*
- 1GB Same as accessory 1G except using 120 volt AC external input*

* add suffix 1 to include external power to power manager or power meter when applicable

Manual Controls for Automatic Transfer Switches

- 6C Reset switch for manual retransfer to normal with automatic retransfer in the event of emergency source failure.
- 6D Selector switch for automatic/manual retransfer to normal. Automatic bypass if emergency fails.

Indicators

- 14A/14B Additional auxiliary contact sets to indicate switch position. Two sets are standard. Specify total number of sets if more are required.
- 18B Two-pole, double-throw contacts operate when emergency source voltage is present at transfer switch terminals.
- 18G Two-pole, double-throw contacts operate when normal source voltage is present at transfer switch terminals.
- 99 "Push-to-Test" feature on all pilot light indicators.

Customer Control Circuits

- 30A Load-shedding circuit initiated by opening of a customer-supplied contact.
- 30B* Load-shedding circuit initiated by removal of customer-supplied control voltage. *(Specify voltage).
- 31Z Selective load disconnect control contacts (two provided) which operate with time delay prior to and/or after load transfer and retransfer.
- 43R Terminal block for all customer control connections on 30-150 amp only (standard on all other sizes).

Note: An externally operable quick-make, quick-break (QMQB), manual handle is available on some 7000 SERIES product configurations. (Consult ASCO for guidance.)

Neutral Conductor Options

- Solid neutral, with fully-rated terminals. (AL-CU) UL Listed.
- Conventional neutral switching pole.
- Overlapping neutral transfer contacts. Allows for proper ground-fault sensing and avoids generator voltage transients during transfer.

Note: Specify neutral option in catalog number, see page 22 for instructions.

Extension Harness

- 37B Six foot (6') extension harness to increase distance between transfer switch and control panel on open-type units.

Communications

- 72E 5150 Ethernet Connectivity Module offers communication to transfer switch and metering with embedded web pages.
- 72SW An Industrial Ethernet Switch mounted in the enclosure used in conjunction with 5150 Connectivity Module (acc. 72E) metering device. Includes 2 available Ethernet ports and 2 multimode ST Fiber connectors.

Surge Protection

ASCO Pulsar 450 rated 65KA

- 73AC1 Normal source protection. (3Ø, 4wire WYE)
- 73AC2 Emergency source protection. (3Ø, 4wire WYE)
- 73AC3 Load side protection. (3Ø, 4wire WYE)

Note: Other distribution voltages available (Contact ASCO).

Special Applications

- 45 Custom Alphanumeric nameplate mounted on the front of the switch
- 111A Generator - to - Generator for Standby Applications
- 111B Generator - to - Generator for Prime Power Applications
- 125 Seismic Certification to the requirements of the international building code for electrical equipment
- 131 Certification of compliance with the American Recovery & Reinvestment ACT (Buy American Provision) - Must be specified at time of order placement

Bypass-Isolation Switch Options

- 14A1 Auxiliary contact to close in "Bypass to Normal" position.
- 14B1 Auxiliary contact to close in "Bypass to Emergency" position.
- 14T Auxiliary contact to close when transfer switch is in "Automatic" position.
- 14U Auxiliary contact to close when transfer switch is in "Isolate" position.
- 14V Auxiliary; contact to close when transfer switch is in "Test" position.
- 82C Automatic shutters for bus isolation when transfer switch is withdrawn. (see page 6 for details)
- 82E LED Bypass status indicator, optional on G frame 1600A-4000A only. Standard for all other size switches

ASCO 5200 SERIES METERING

Power Manager

The ASCO 5200 SERIES Power Meters are microprocessor based metering devices that provides real-time measurement of single and three phase power systems. The 5200 SERIES uses digital signal processing technology to measure voltage and current per phase; real, reactive and apparent power, and bi-directional energy. All measurements can be viewed locally with a backlit liquid crystal display and/or displayed remotely with ASCO POWERQUEST® products.

Direct voltage input for systems up to 600 Volts AC can be monitored without the use of external potential transformers (PTs). Measures three phase currents and a fourth current input is available for measuring current in the neutral conductor. The 5200 SERIES includes one discrete input for transfer switch position.

Power Metering

- Voltage:
 - Line - Line: VAB, VBC, VCA, VAVERAGE
 - Line - Neutral: VAN, VBN, VCN, VAVERAGE
- Frequency: 45.0 to 66.0 Hertz
- Current: IA, IB, IC, IAVERAGE
- Unbalance %: Voltage, Amps
- Real Power: KWA, KWB, KWC, KWNET
- Reactive Power: KVARA, KVARB, KVARC, KVARNET
- Apparent Power: KVAA, KVAB, KVAC, KVANET
- Real Energy: KWHIMPORT, KWHEXPORT, KWHNET
- Reactive Energy: KVARHIMPORT, KVARHEXPORT, KVARHNET
- Power Factor: PFA, PFB, PFC, PFNET

5220 Power Manager Data Access

- Eight digital inputs, four relay outputs.
- Input/Output 15-character, user definable screen display for identification of input/output signals.

Communications

- Modbus RTU and TCP/IP capability
- Ethernet compatible when combined with 5150 Connectivity Module (72E).

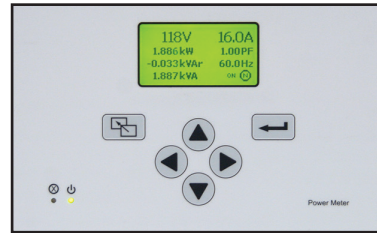

Fig. 19: ASCO 5210 SERIES Power Meter.



Fig. 20: ASCO 5220 SERIES Power Manager.

Configurable Designations

- Local - A four line, 20 character LCD backlit display.
- 5220 Power Manager provides user programmable setpoints based on twelve metering and I/O parameters. Each setpoint allows the user to select the parameter, the trip & reset levels, the trip & reset time delays and the alarm type or relay output to trigger. This can be used for protective relaying and peak shaving applications.
- 100 event data logging feature.

Integrated ATS Features

When configured on load of ATS:

- Displays ATS position.
- Displays power data as a function of ATS position (normal/emergency).
- Accumulates energy data separately for normal and emergency sources.

Optional Configurations and Connection Arrangements

| Connected To: | 5210 | 5220 |
|-----------------|-----------|------------|
| Load | Acc. 135L | Acc. 85L |
| Normal | Acc. 135L | Acc. 85N |
| Emergency | Acc. 135E | Acc. 85M |
| Load (BPS only) | N/A | Acc. 85SB* |

Add suffix A1 to above metering designation if neutral conductor monitoring is required

Note: Accessory 85L and 135L includes component mounting, CTs, shorting blocks and all necessary interwiring.

*Bypass & isolation switch contacts wired to discrete Power Manager inputs.

Note: The ASCO Power Manager is also available as a separate unit for monitoring electrical parameters anywhere in the power distribution system.



FULFILL YOUR NEED

Drill down for a closer look - Each transfer switch, generator, breaker and any other power equipment has its own dedicated screens.

It's the new ASCO PowerQuest® Power Monitoring and Control family.

The PowerQuest® family is the most comprehensive communication, monitoring and control solution ever offered by ASCO. It empowers you. It fulfills your need to test, manage loads, optimize the bus bar, remotely monitor and otherwise be aware of the status of your facility's utility source and on-site power. You have both the Power to Know and the Power to Do.

Whether you require standard monitoring and control, or a comprehensive Critical Power Management System, PowerQuest can satisfy your needs.

Hardware. Software. Installation and testing. Service. And upgrades and technology refreshes. A truly complete solution for all your communication, monitoring and control needs.

The following PowerQuest® pages can help you determine—easily—the type of PowerQuest system you need for your ASCO power switching and controls, and third-party equipment.

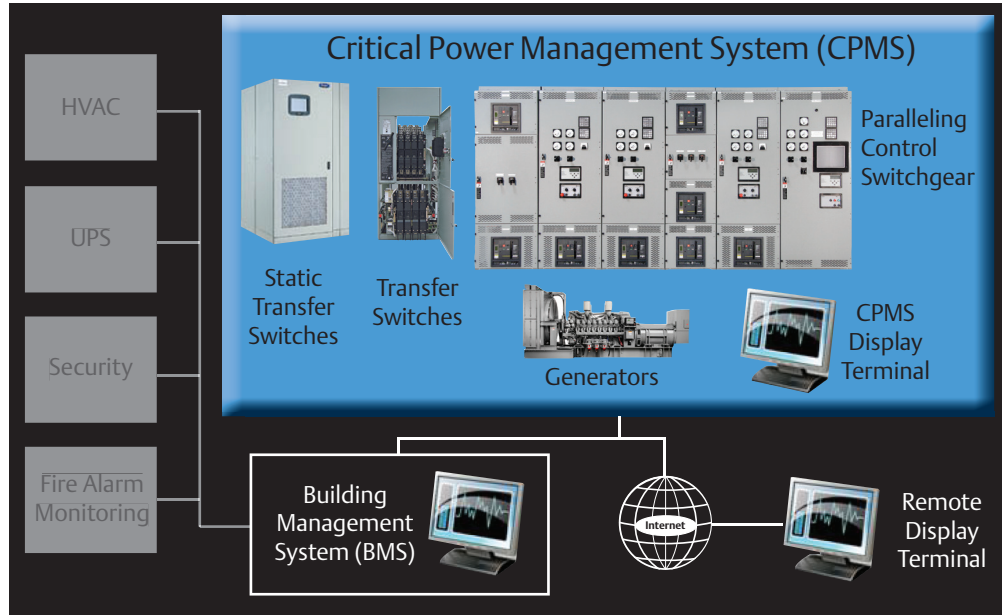

PowerQuest® provides monitoring, alarming and control of Critical Power Management Systems, which comprise transfer switches, paralleling control switchgear, gensets, circuit breakers, distribution and other gear. It also integrates with building management systems.

BE EMPOWERED

PowerQuest® can enable you to:

- Monitor and control power transfer switches, paralleling control switchgear, gensets, breakers, bus bars and other equipment
- Monitor normal and emergency voltages and frequency and their settings
- Know transfer switch position and source availability
- Transfer and re-transfer loads for system testing
- View and adjust transfer switch time-delay settings
- Know each transfer switch's rating and identification
- Receive automatic alerts on system operation via e-mail, pager, or selected system alarms
- View current, power and power factor
- View transfer switch event log and know the transfer switch test schedule

ASCO® 7000 SERIES PowerQuest® Monitoring & Control Components

Building-block components can be configured easily to provide exactly the degree of monitoring, control and communication you want for your on-site power system.

5150, 5160
Connectivity
Modules



An ASCO 5150 Connectivity Module (left) provides 100 Mbps Ethernet Connectivity for ASCO Transfer Switches and Power Meters and includes AES 128-bit Encryption, as per NIST, for enhanced security.

The ASCO 5160 Remote Connectivity Unit (RCU) (right) provides 10 Ethernet and Dual-Fiber Optic connections in a NEMA 3R enclosure.

5210, 5220
Power
Meters



ASCO 5210 (left) and 5220 (right) Power Meters measure, displays and provides single- or 3-phase Energy and Power information with Ethernet via the ASCO 5150 Communication Module.

5310, 5350
Annunciators



ASCO 5310(left) and 5350(right) ATS Remote Annunciators provide distributed monitoring of transfer switch position and source availability as well as transfer test and re-transfer control.

Note: On the 7000 Series Non-Automatic Transfer Switch, the Remote Annunciator (5350) will provide switch status but not control.

5010 Remote
Display Unit,(left)
5490 Critical
Power Quality
Meter, (right)



ASCO 5400 SERIES Power Quality Meters

The ASCO Power Quality Meters provide intelligent power analysis, energy measurement and event recording for critical and sensitive loads. Its unique continuous waveform and harmonic recording capabilities ensure all events are captured, improves response time, and helps identify corrective action to power quality related issues.



Enterprise
Critical Power
Management
System



5700 SERIES provide various levels of monitoring, control and management capability of power equipment. It seamlessly monitors ASCO transfer switches as well as generators, breakers, paralleling bus, panel boards and other power equipment via a 5221 PMU. It consists of servers and touch screen interfaces.

The Power To Know

Selecting the system that provides your level of need-to-know information and control...

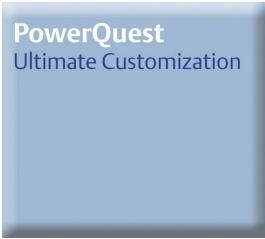
| | You Need... | Your Application Is... | Desired Capabilities |
|---|---|---|--|
|  <p>PowerQuest Standard Capabilities</p> | <p>Basic monitoring, remote alarming and control, or, if you simply want to know transfer switch status or perform monthly transfer testing</p> | <p>Residential, light commercial and retail establishments</p> | <p>Local or remote, floor-level monitoring and control, or as part of a larger, facility-wide monitoring and control system</p> |
|  <p>PowerQuest Configurable Flexibility</p> <p>Essential Professional Enterprise</p> | <p>A 'specify-your-own' Critical Power Management System (CPMS) that includes gensets, circuit breakers, and reports on energy, trending, power demand, bypass status, diagnostics, alarming, and component-level monitoring and control.</p> | <p>Commercial, retail, telecom, agriculture, municipal, such as waste water treatment, light industrial plants, educational campuses and healthcare facilities requiring distributed power and load management</p> | <p>Local, floor-level, or facility-level monitoring and control; 5700 systems can be configured in three capability levels:</p> <ul style="list-style-type: none"> • Essential (single building) • Professional (multiple buildings, single campus) • Enterprise (multiple campuses) |
|  <p>PowerQuest Ultimate Customization</p> | <p>A Critical Power Management System providing system-wide monitoring, alarming and control of transfer switches, paralleling control switchgear, gensets and distribution, both on and off site; also integrates PLCs, building management systems and on-site, simulator training. Power quality and a range of other information is provided.</p> | <p>Regional and global networks of data centers, financial institutions, Web hosting companies and healthcare campuses that operate expansive and sophisticated on-site power systems that are essential for providing 24/7 power reliability</p> | <p>Local floor-level monitoring and control, and remote system-wide monitoring and control seamlessly integrated with building management systems; communication paths can be Ethernet, Web-based PC's and monitors; simulator training that mimics the live system allows conducting 'what if' scenarios, without risking system operation.</p> |

Identifies the ASCO products and components required to provide the functionality you need.

Products

Required Components

Functionality

ASCO Series 185 and Series 300 Automatic Transfer Switches

Connectivity Modules and Annunciators



Locally monitor switch position, source availability and the status of on-site power system devices via customized Web page. Initiate tests and push-button remote transfer. Aural, visual alarms.

ASCO 4000 Series and 7000 Series Automatic Transfer Switches, including 7000 Series Bypass-Isolation

Standard components, plus Power Control System Management and Operator Interface Terminals



Monitor voltage and phase currents. Capture/store more data points. Display data on screen up to 42" inches. Interface with power control system, BMS. Integrate with Group 5 Controller. Get email alerts. For single buildings, single campuses and global facilities. Provides Energy, Alarm, and Outage/Test Reports that can be used to fulfill Joint Commission Requirements.

ASCO 7000 Series Automatic Transfer Switches, including Bypass-Isolation and 7000 Series Generator Paralleling Control Switchgear

Standard and Configurable components, plus higher performance Power Control System and Data Management Screens, and an on-site Simulator Training System



Interact fully with incoming utility service boards, mission critical paralleling gear, transfer switches, UPSs, STSs and PDUs... and interface with Building Management Systems. Capture, store and analyze quantities of data to optimize on-site power operation. Use your display devices and/or ASCO 42" LCD screen. Highly customize your GUI with sophisticated HMI/SCADA software.

ASCO® PowerQuest® 5700 Critical Power Management System

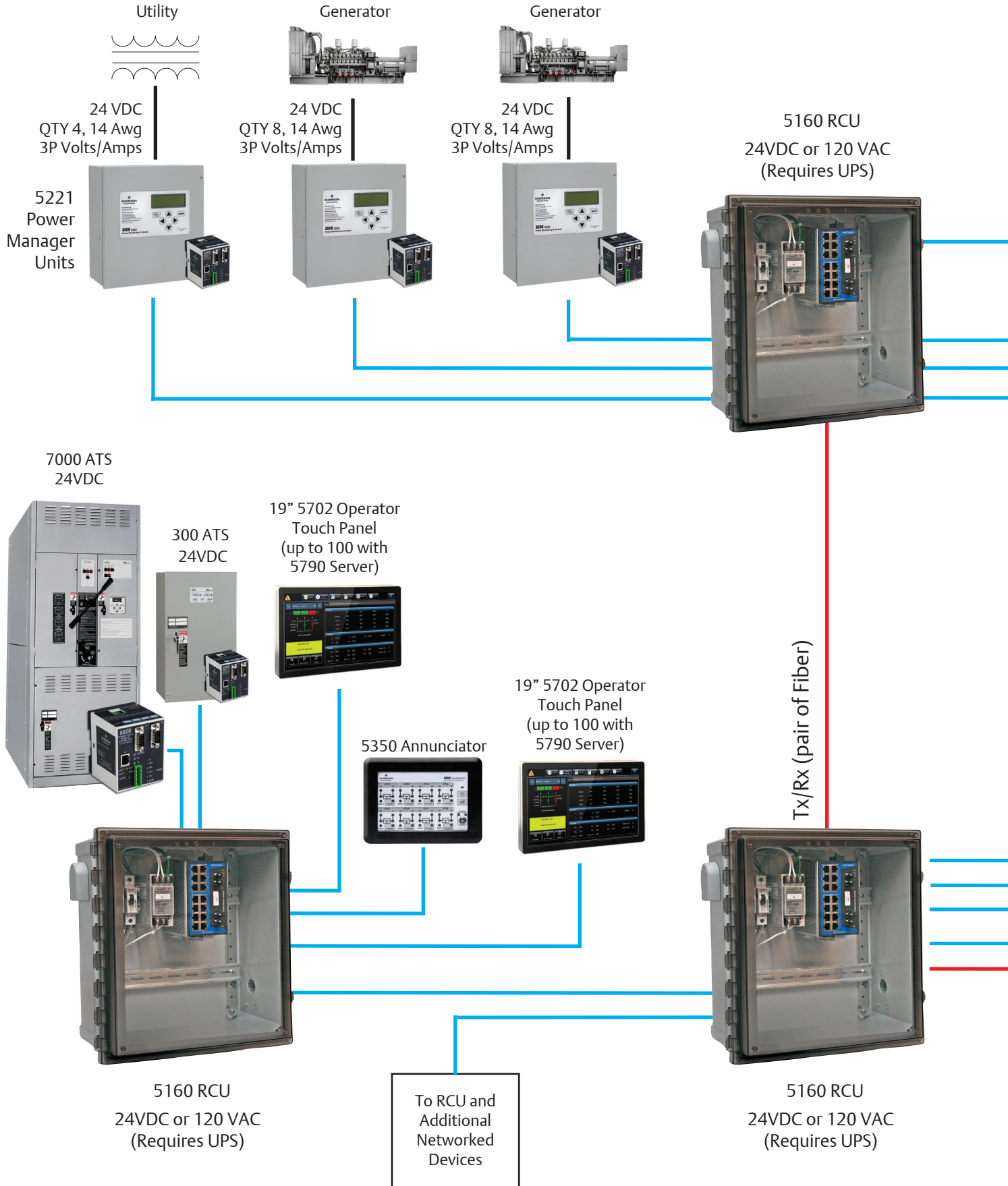

Breaker



24 VDC
QTY 4, 14 Awg
3P Volts/Amps



UPS/Distribution



24 VDC
QTY 8, 14 Awg
3P Volts/Amps



7000 ATS



19" 5702 Operator
Touch Panel
(up to 100 with
5790 Server)



5350 Annunciator
ATS Status Annunciation
Transfer Test
Supports 8 ATS's
24VDC/120VAC/220VAC

5710 CPMS Server

- Drives 3 Remote 5702 Panels
- Supports 32 Power Devices
- Basic Monitoring and Control
- Standard Performance

5700 CPMS Servers
Note - Select One Server to install
in Centralized Office
50° to 95°F (10°C to 35°C)

5750 CPMS Server

Essential Features PLUS:

- Drives 10 Remote 5702 Panels
- Supports 64 Power Devices
- Historical Trending
- 5 Reporting Packages
- BMS Modbus Support
- Remote E-Mail Alarming

5790 CPMS Server

Professional Features PLUS:

- Drives 100 5702 Touch Panels
- Redundant Power
- Redundant Storage
- Redundant Processors
- Ultimate Performance
- 128 Power Devices
- Expanded Storage
- Inter-facility Messaging

To RCU and
Additional
Networked
Devices

- AWG Wire Size and Distance by others
- Category 6 Ethernet (300 Feet Max)
- Multi-Mode Fiber, 1300nm, 50/125um, ST Connectors (6500) Feet Max

NOTES -

1. This Drawing is to be used as a Model only; Actual network architecture will depend on equipment placement, cable length and type.
2. 5700 Series Products Operating Temperature is 50° to 95°F (10°C to 35°C) For altitudes above 2950 feet, the maximum operating temperature is derated 1°F/550 ft.

ASCO® 7000 SERIES Ordering Information

To order an ASCO 7000 SERIES Power Transfer Switch, complete the following catalog number:

7 A TS + A + 3 + 400 + N + 5X + C

| | | Product | | Neutral Code* | | Phase Poles | Amperes | Voltage Code | | Grp Code | Enclosure | |
|---|-------------------|---------|---------------------------|---------------|---------------------|-------------|------------------|--------------|-----|--|-----------|--|
| A | Automatic | TS | Conventional 2-Position | --- | No Neutral | 2 | 30 | A | 115 | 5 5X- optional accesso- ries | --- | No enclosure |
| | | | | | | | 3 | 70 | B | | 120 | C |
| N | Non-Automatic | TB | Open Transition Bypass | A | Solid Neutral | | 100 | C | 208 | | F | Type 3R ³ enclosure |
| | | | | | | | 150 | D | 220 | | G | Type 4 enclosure |
| | | CTS | Closed Transition | | | | 200 ¹ | E | 230 | | H | Type 4X ² enclosure (304 stainless steel) |
| | | | | | | | 230 ¹ | F | 240 | | L | Type 12 enclosure |
| | | CTB | Closed Transition Bypass | B | Switched Neutral | | 260 | H | 380 | | M | Type 3R ³ secure double door |
| | | | | | | | 400 | J | 400 | | N | Type 4 secure double door |
| M | Manually Operated | DTS | Delayed Transition | C | Overlapping Neutral | | 600 | K | 415 | | P | Type 4X ² secure double door (304 stainless steel) |
| | | | | | | | 800 | L | 440 | | Q | Type 12 secure double door |
| | | DTB | Delayed Transition Bypass | | | | 1000 | M | 460 | | R | Type 3RX ² secure double door (304 stainless steel) |
| | | | | | | | 1200 | N | 480 | | U | Type 4X enclosure (316 stainless steel) |
| | | | | | | 1600 | P | 550 | V | Type 4X secure double door (316 stainless steel) | | |
| | | | | | | 2000 | Q | 575 | | | | |
| | | | | 2600 | R | 600 | | | | | | |
| | | | | 3000 | | | | | | | | |
| | | | | 4000 | | | | | | | | |

- *Notes: 1. 200 and 230 amp switch limited to 480 volts maximum.
 2. Type 304 stainless steel is standard. To provide an improved reduction in corrosion in salt or marine environments, specify optional type 316 stainless steel.
 3. Type 3R enclosures are not suitable for installations conducive to windblown snow or rain conditions.
 4. Conventional switch neutral is provided on closed and delayed transition transfer products when specified.

5. A comprehensive ASCO Limited Guardian Warranty covers 7000 Series Power Transfer Switch(s) and warrants the product to be free of defects in material and workmanship from date of shipment. The warranty provides:

- 2 years for labor and travel expenses (extendable in 1 year increments up to 5 years for a nominal fee).
- 5 years for parts (2 years for circuit breakers).
- 10 years for main contacts.

Refer to Publication 3227 for warranty details, terms and conditions.

The Example Catalog Number above is 7ATS3400N5XC
(X is used to specify optional accessories).

Transfer Switch Configurations

7ATS, 7NTS, 7ADTS, 7ACTS, 7NDTS, 7NCTS
 Sizes of UL-Listed Solderless Screw-Type
 Terminals for External Power Connections

| Switch Rating amps | Max # of Conductors per Terminal | Range of AL-CU Conductor Sizes |
|---|----------------------------------|--------------------------------|
| 30 - 230 ³ ATS & NTS Only | One | #14 to 4/0 AWG |
| 150*, 260, 400 *150 for CTS and DTS Only | One | #4 AWG to 600 MCM |
| | Two | #1/0 AWG to 250 MCM |
| 600 | Two | #1/0 AWG to 600 MCM |
| 800-1200 ¹ | Four | #1/0 AWG to 600 MCM |
| 1600-2000 ² | Six | #1/0 AWG to 600 MCM |
| 2600-3000 ² | Twelve | #1/0 AWG to 600 MCM |
| 4000 ² | Twelve | #2/0 AWG to 600 MCM |

- Notes: 1. Unit is designed for top cable entry of emergency and load and bottom entry of normal. Optionally, the switch may be supplied with reverse source and/or bottom entry load, when specified.
 2. All main terminals are rear connected.

Transfer/Bypass Configurations

7ATB, 7NTB, 7ADTB, 7ACTB, 7NDTB, 7NCTB
 Sizes of UL-Listed Solderless Screw-Type
 Terminal for Power Connections

| Switch Rating amps | Max # of Conductors per Terminal | Range of AL-CU Conductor Sizes |
|--------------------------------|----------------------------------|--------------------------------|
| 150, 200, 230 260,400 | One | # 4 AWG to 600 MCM |
| | Two | # 1/0 AWG to 250 MCM |
| 600 ⁴ | Two | # 2 AWG to 600 MCM |
| 800,1000,1200 Front Connect | Three | # 1/0 AWG to 600 MCM |
| 800,1000,1200 ⁴ | Four | # 1/0 AWG to 600 MCM |
| 1600-2000 ⁴ | Six | # 1/0 AWG to 600 MCM |
| 2600, 3000 ⁴ | Ten | # 1/0 AWG to 600 MCM |
| 4000 ⁴ | Twelve | # 2 AWG to 600 MCM |

3. 200 and 230 amp rating for copper conductors only for transfer switch configurations only.
 4. All main terminals are rear connected. A front connected version is available in 600 and 1200 amp ratings only with top cable entry only. See pages 25-27 for dimensional data and additional information.

ASCO® 7000 SERIES Designed to Fit Anywhere*

2-Position Transfer Switching 7ATS, 7NTS (Non-Bypass)

| Frame | Switch Rating Amps | Width Inches (mm) | Height Inches (mm) | Depth Inches (mm) |
|---------------------------------------|---|-------------------|--------------------|-------------------|
| Enclosed UL Type 1² | | | | |
| D | 30, 70, 100, 150, 200, 230 | 18 (457) | 48 (1219) | 13 (330) |
| J | 260, 400 | 24 (610) | 56 (1422) | 14 (356) |
| J | 600 | 24 (610) | 63 (1600) | 17 (432) |
| H | 800, 1000 | 34 (864) | 72 (1829) | 20 (508) |
| H | 1200 | 38 (965) | 87 (2210) | 23 (584) |
| G | 1600, 2000 ¹ | 38 (965) | 91 (2311) | 60 (1524) |
| G | 1600, 2000 ³ (Front Connected) | 38 (965) | 87 (2210) | 23 (584) |
| G | 2600, 3000 ¹ | 38 (965) | 91 (2311) | 60 (1524) |
| G | 4000 ¹ | 60 (1524) | 92 (2311) | 72 (1829) |
| Open Configuration | | | | |
| D | 30, 70, 100, 125, 150, 200, 230 | 10¼ (260) | 10¼ (260) | 5½ (140) |
| J | 260, 400 | 18½ (470) | 25 (635) | 8 (203) |
| J | 600 | 19 (483) | 30 (762) | 9⅞ (251) |
| H | 800, 1000, 1200 | 27 (686) | 31 (787) | 12⅞ (327) |
| G | 1600, 2000 | 33¼ (845) | 28 (711) | 26¼ (667) |
| G | 2600, 3000 | 33¼ (845) | 29 (711) | 30¾ (781) |
| G | 4000 | 60 (1524) | 70 (1778) | 53 (1272) |

Notes:

1. Enclosures are free-standing with removable top, sides, and back.
2. Consult ASCO for dimensions on enclosures other than UL type 1.
3. Order accessory 40MY for 1600A and 40NY for 2000A F/C design.

*All dimensions and weights shown are approximate and should not be used for construction purposes. Certified dimensions can be furnished upon request.

Shipping Weights

2-Position Transfer Switching 7ATS, 7NTS

| Frame | Switch Rating Amps | Poles | Enclosed lb (kg) | Open lb (kg) |
|-------|--------------------|------------|------------------|--------------|
| D | 30, 70, 100 | 2 | 70 (32) | 30 (14) |
| D | 30, 70, 100 | 3 | 80 (36) | 35 (16) |
| D | 30, 70, 100 | 3 with B/C | 85 (39) | 40 (18) |
| D | 150, 200, 230 | 2 | 115 (52) | 35 (16) |
| D | 150, 200, 230 | 3 | 120 (55) | 40 (18) |
| D | 150, 200, 230 | 3 with B/C | 130 (59) | 45 (21) |
| J | 260, 400 | 2 | 270 (123) | 220 (100) |
| J | 260, 400 | 3 | 280 (128) | 230 (105) |
| J | 260, 400 | 3 with B/C | 290 (132) | 240 (109) |
| J | 600 | 2 | 370 (169) | 260 (119) |
| J | 600 | 3 | 380 (173) | 270 (123) |
| J | 600 | 3 with B/C | 390 (178) | 280 (128) |
| H | 800, 1000 | 2 | 470 (214) | 260 (119) |
| H | 800, 1000 | 3 | 480 (219) | 270 (123) |
| H | 800, 1000 | 3 with B/C | 490 (223) | 280 (128) |
| H | 1200 | 2 | 670 (308) | 300 (137) |
| H | 1200 | 3 | 680 (310) | 310 (141) |
| H | 1200 | 3 with B/C | 690 (315) | 320 (146) |

| Frame | Switch Rating Amps | Poles | Enclosed lb (kg) | Open lb (kg) |
|-------|-------------------------|------------|------------------|--------------|
| G | 1600, 2000 ² | 2 | 1330 (606) | 450 (205) |
| G | 1600, 2000 ² | 3 | 1350 (616) | 470 (214) |
| G | 1600, 2000 ² | 3 with B/C | 1400 (638) | 500 (228) |
| G | 2600, 3000 | 2 | 2150 (980) | 890 (406) |
| G | 2600, 3000 | 3 | 2180 (994) | 920 (420) |
| G | 2600, 3000 | 3 with B/C | 2230 (1017) | 1000 (456) |
| G | 4000 | 2 | 2250 (1026) | 990 (451) |
| G | 4000 | 3 | 2280 (1040) | 1020 (465) |
| G | 4000 | 3 with B/C | 2330 (1062) | 1100 (502) |

Notes:

1. Open weights include transfer switch and controller. 1200-4000 amp enclosures require ventilation openings, refer to drawing for details.
2. Weights for 1600 and 2000 amp are based on rear connected design.

*All dimensions and weights shown are approximate and should not be used for construction purposes. Certified dimensions can be furnished upon request.

ASCO® 7000 SERIES Designed to Fit Anywhere*

Closed Transition and Delayed Transition Transfer Switching 7ADTS, 7ACTS, 7NDTS, 7NCTS

| Frame | Switch Rating Amps | Width Inches (mm) | Height Inches (mm) | Depth Inches (mm) |
|---------------------------------------|---|-------------------|--------------------|-------------------|
| Enclosed UL Type 1² | | | | |
| J | 150, 260, 400 | 24 (610) | 56 (1422) | 14 (356) |
| J | 600 | 24 (610) | 63 (1600) | 17 (432) |
| H | 800, 1000 | 34 (864) | 72 (1829) | 20 (508) |
| H | 1200 | 38 (965) | 87 (2210) | 23 (584) |
| G | 1600, 2000 ¹ | 38 (965) | 91 (2311) | 48 (1219) |
| G | 1600, 2000 ³ (Front Connected) | 38 (965) | 87 (2210) | 23½ (597) |
| G | 2600, 3000 ¹ | 38 (965) | 91 (2311) | 60 (1524) |
| G | 4000 ¹ | 60 (1524) | 92 (2311) | 72 (1829) |
| Open Configuration | | | | |
| J | 150, 260, 400 | 18½ (470) | 25 (635) | 8 (203) |
| J | 600 | 19 (483) | 30 (762) | 9⅞ (251) |
| H | 800, 1000, 1200 | 27 (686) | 31 (787) | 12⅞ (327) |
| G | 1600, 2000 | 33¼ (845) | 28 (711) | 26¼ (667) |
| G | 2600, 3000 | 33¼ (845) | 29 (711) | 30¾ (781) |
| G | 4000 | 60 (1524) | 70 (1778) | 53 (1272) |

Notes:

1. Enclosures are free-standing with removable top, sides, and back.
2. Consult ASCO for dimensions on enclosures other than UL type 1.
3. Order accessory 40MY for 1600A and 40NY for 2000A front connected design.

* All dimensions and weights shown are approximate and should not be used for construction purposes. Certified dimensions can be furnished upon request.

Shipping Weights Closed Transition and Delayed Transition Transfer Switching 7ADTS, 7ACTS, 7NDTS, 7NCTS

| Frame | Switch Rating Amps | Poles | Enclosed lb (kg) | Open lb (kg) |
|-------|-------------------------|----------|------------------|--------------|
| J | 150, 260, 400 | 3 | 320 (146) | 220 (100) |
| J | 150, 260, 40 | 3 with B | 330 (150) | 230 (105) |
| J | 600 | 3 | 380 (173) | 260 (119) |
| J | 600 | 3 with B | 390 (178) | 270 (123) |
| H | 800, 1000 | 3 | 480 (219) | 360 (164) |
| H | 800, 1000 | 3 with B | 490 (223) | 370 (169) |
| H | 1200 | 3 | 680 (310) | 360 (164) |
| H | 1200 | 3 with B | 690 (315) | 380 (173) |
| G | 1600, 2000 ² | 3 | 1350 (616) | 580 (264) |
| G | 1600, 2000 ² | 3 with B | 1400 (638) | 600 (274) |
| G | 2600, 3000 | 3 | 2180 (994) | 1060 (483) |
| G | 2600, 3000 | 3 with B | 2230 (1017) | 1100 (502) |
| G | 4000 | 3 | 2290 (1044) | 1060 (483) |
| G | 4000 | 3 with B | 2380 (1085) | 1140 (520) |

Notes:

1. Open weights include transfer switch and control panel. 1200-4000 amp enclosures require ventilation openings, refer to drawings for details.
2. Weights for 1600 and 2000 amp are based on rear connected design

* All dimensions and weights shown are approximate and should not be used for construction purposes. Certified dimensions can be furnished upon request.

ASCO® 7000 SERIES Designed to Fit Anywhere*

Automatic Transfer Bypass-Isolation Switching with Transfer Switch Engaged 7ATB, 7NTB

| Frame | Switch Rating Amps | Power Connection Configuration | Width Inches (mm) | Height Inches (mm) | Depth Inches (mm) |
|-------|-------------------------------------|--------------------------------|-------------------|--------------------|-------------------|
| | Enclosed UL Type 1 | | | | |
| J | 150, 200, 230, 260, 400, 600 | Front Connected | 34 (864) | 85 (2159) | 28 (711) |
| H | 800 ³ | Front Connected | 38 (965) | 91 (2311) | 32 (813) |
| H | 1000, 1200 ³ | Front Connected | 38 (965) | 91 (2311) | 34 (864) |
| H | 600, 800, 1000, 1200 ¹ | Rear Connected | 38 (965) | 91 (2311) | 48 (1219) |
| G | 1600, 2000 ² | Rear Connected | 38 (965) | 91 (2311) | 60 (1524) |
| G | 2600, 3000 ² | Rear Connected | 38 (965) | 91 (2311) | 72 (1829) |
| G | 4000 ² | Rear Connected | 60 (1524) | 91 (2311) | 96 (2438) |
| | Open Configuration | | | | |
| J | 150, 200, 230, 400, 600 | Front Connected | 34 (864) | 85 (2159) | 28 (711) |
| H | 600, 800, 1000, 1200 ² | Rear Connected | 38 (965) | 72 (1829) | 38 (965) |
| G | 1600, 2000, 2600, 3000 ² | Rear Connected | 38 (965) | 72 (1829) | 38 (965) |
| G | 4000 ¹ | Rear Connected | 60 (1524) | 91 (2311) | 96 (2438) |

Notes: 1. Handles extend 6-1/4 inches (159mm).

2. Recommended clearance to enclosure: 3 feet (914mm) from rear, 4 feet (1219mm) from front (25 inches required for transfer switch drawout). Side or rear access required.

3. Specify optional accessory 40J Y for 800 Amp front, 40KY for 1000 Amp, and 40LY for 1200 Amp - connected arrangement. All service and load cables limited to top entry only.

*All dimensions and weights shown are approximate and should not be used for construction purposes. Certified dimensions can be furnished upon request.

Shipping Weights Automatic Transfer Bypass-Isolation Switching with Transfer Switch Engaged 7ATB, 7NTB

| Frame | Switch Rating Amps | Poles | Enclosed lb (kg) | Open lb (kg) |
|-------|---|------------|------------------|--------------|
| J | 150, 200, 230, 260, 400 (Front Connected) | 2 | 1230 (561) | 1100 (502) |
| J | 150, 200, 230, 260, 400 (Front Connected) | 3 | 1240 (565) | 1110 (506) |
| J | 150, 200, 230, 260, 400 (Front Connected) | 3 with B/C | 1260 (575) | 1130 (515) |
| J | 600 (Front Connected) | 2 | 1290 (588) | 1190 (543) |
| J | 600 (Front Connected) | 3 | 1300 (593) | 1200 (547) |
| J | 600 (Front Connected) | 3 with B/C | 1320 (602) | 1220 (556) |
| H | 600, 800, 1000 (Rear Connected) | 3 | 1720 (784) | 1260 (575) |
| H | 600, 800, 1000 (Rear Connected) | 3 with B/C | 1740 (793) | 1280 (584) |
| H | 1200 (Rear Connected) | 3 | 1820 (830) | 1290 (588) |
| H | 1200 (Rear Connected) | 3 with B/C | 1840 (839) | 1310 (597) |
| H | 800 (Front Connected) | 3 | 1400 (638) | 1320 (602) |
| H | 800 (Front Connected) | 3 with B/C | 1420 (648) | 1340 (611) |
| G | 1600, 2000 (Rear Connected) | 3 | 2360 (1076) | 1500 (684) |
| G | 1600, 2000 (Rear Connected) | 3 with B/C | 2540 (1158) | 1680 (766) |
| G | 2600, 3000 (Rear Connected) | 3 | 2730 (1245) | 1690 (771) |
| G | 2600, 3000 (Rear Connected) | 3 with B/C | 3360 (1532) | 2290 (1044) |
| G | 4000 (Rear Connected) | 3 | 6300 (2873) | Contact ASCO |
| G | 4000 (Rear Connected) | 3 with B/C | 6900 (3146) | Contact ASCO |

Notes: 1. Open weights include transfer switch, bypass-isolation switch and controller.

1600-4000 amp enclosures require ventilation openings, refer to drawings for details.

*All dimensions and weights shown are approximate and should not be used for construction purposes. Certified dimensions can be furnished upon request.

ASCO® 7000 SERIES Designed to Fit Anywhere*

Automatic Transfer Bypass-Isolation in Closed Transition and Delayed Transition Switching. 7ADTB, 7ACTB, 7NDTB, 7NCTB

| Frame | Switch Rating Amps | Power Connection Configuration | Width Inches (mm) | Height Inches (mm) | Depth Inches (mm) |
|-------------------------------------|-------------------------------------|--------------------------------|-------------------|--------------------|-------------------|
| Enclosed UL Type¹ | | | | | |
| J | 150, 200, 230, 260, 400, 600 | Front Connected | 34 (864) | 85 (2159) | 28 (711) |
| H | 800 ³ | Front Connected | 38 (965) | 91 (2311) | 32 (813) |
| H | 1000, 1200 | Front Connected | 38 (965) | 91 (2311) | 34 (864) |
| H | 600, 800, 1000, 1200 ² | Rear Connected | 38 (965) | 91 (2311) | 48 (1219) |
| G | 1600, 2000 ² | Rear Connected | 38 (965) | 91 (2311) | 60 (1524) |
| G | 2600, 3000 ² | Rear Connected | 38 (965) | 91 (2311) | 72 (1829) |
| G | 4000 ² | Rear Connected | 60 (1524) | 91 (2311) | 96 (2438) |
| Open Configuration | | | | | |
| J | 150, 200, 230, 400, 600 | Front Connected | 34 (864) | 85 (2159) | 28 (711) |
| H | 600, 800, 1000, 1200 ² | Rear Connected | 38 (965) | 72 (1829) | 38 (965) |
| G | 1600, 2000, 2600, 3000 ² | Rear Connected | 38 (965) | 72 (1829) | 38 (965) |
| G | 4000 ² | Rear Connected | 60 (1524) | 91 (2311) | 96 (2438) |

- Notes: 1. Handles extend 6-1/4 inches (159mm).
 2. Recommended clearance to enclosure: 3 feet (914mm) from rear, 4 feet (1219mm) from front (25 inches required for transfer switch drawout). Side or rear access required.
 3. Specify optional accessory 40J Y for 800 Amp front, 40KY for 1000 Amp, and 40LY for 1200 Amp - connected arrangement. All service and load cables limited to top entry only.
 *All dimensions and weights shown are approximate and should not be used for construction purposes. Certified dimensions can be furnished upon request.

Shipping Weights Automatic Transfer Bypass-Isolation in Closed Transition and Delayed Transition Switching. 7ADTB, 7ACTB, 7NDTB, 7NCTB

| Frame | Switch Rating Amps | Poles | Enclosed lb (kg) | Open lb (kg) |
|-------|---|------------|------------------|--------------|
| J | 150, 200, 230, 260, 400 (Front Connected) | 2 | 1255 (572) | 1125 (513) |
| J | 150, 200, 230, 260, 400 (Front Connected) | 3 | 1265 (577) | 1135 (518) |
| J | 150, 200, 230, 260, 400 (Front Connected) | 3 with B/C | 1285 (586) | 1155 (527) |
| J | 600 (Front Connected) | 2 | 1315 (600) | 1215 (554) |
| J | 600 (Front Connected) | 3 | 1325 (604) | 1225 (559) |
| J | 600 (Front Connected) | 3 with B/C | 1345 (613) | 1245 (568) |
| H | 600, 800, 1000 (Rear Connected) | 3 | 1745 (796) | 1285 (586) |
| H | 600, 800, 1000 (Rear Connected) | 3 with B/C | 1765 (805) | 1280 (595) |
| H | 1200 (Rear Connected) | 3 | 1845 (841) | 1315 (600) |
| H | 1200 (Rear Connected) | 3 with B/C | 1865 (850) | 1335 (609) |
| H | 800 (Front Connected) | 3 | 1425 (650) | 1345 (613) |
| H | 800 (Front Connected) | 3 with B/C | 1445 (659) | 1365 (622) |
| G | 1600, 2000 (Rear Connected) | 3 | 2385 (1088) | 1525 (695) |
| G | 1600, 2000 (Rear Connected) | 3 with B/C | 2565 (1170) | 1705 (777) |
| G | 2600, 3000 (Rear Connected) | 3 | 2755 (1256) | 1715 (782) |
| G | 2600, 3000 (Rear Connected) | 3 with B/C | 3385 (1544) | 2315 (1056) |
| G | 4000 (Rear Connected) | 3 | 6325 (2884) | Contact ASCO |
| G | 4000 (Rear Connected) | 3 with B/C | 6925 (3158) | Contact ASCO |

- Notes: 1. Open weights include transfer switch, bypass-isolation switch and controller.
 1600-4000 amp enclosures require ventilation openings, refer to drawings for details.

*All dimensions and weights shown are approximate and should not be used for construction purposes. Certified dimensions can be furnished upon request.

ASCO[®] 7000 SERIES Designed to Fit Anywhere*

Optional Front Connected Design Saves Valuable Space

800 Amp Optional Front Connected Design

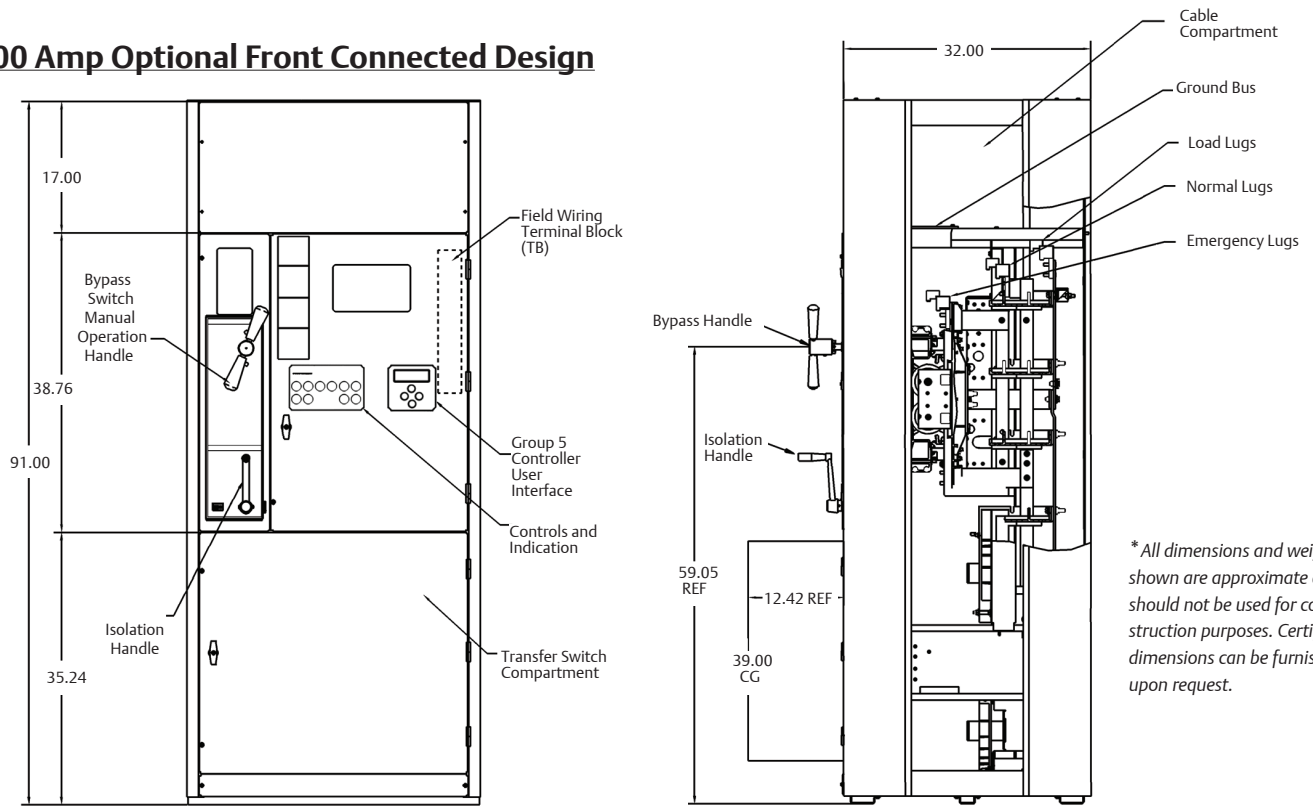

* All dimensions and weights shown are approximate and should not be used for construction purposes. Certified dimensions can be furnished upon request.

Front Views (Covers Installed)

Right Side Views (Covers Removed)

1000-1200 Amp Optional Front Connected Design

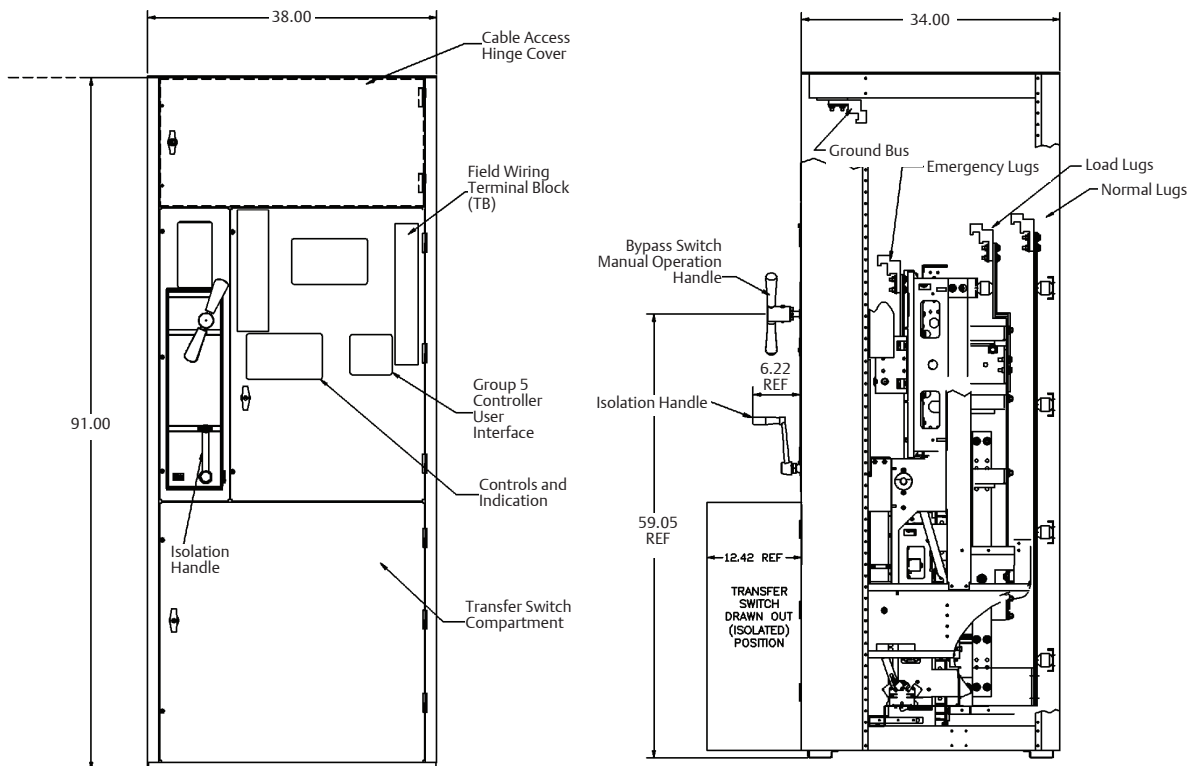

Emerson Network Power - Global Headquarters

1050 Dearborn Drive
Columbus, OH 43085
Tel: +1 614 888 0246

ASCO Power Technologies - Global Headquarters

50 Hanover Road
Florham Park, NJ 07932
Tel: 800 800 ASCO
customer@asco.com

www.EmersonNetworkPower.com/ASCO

www.ascoapu.com