



136-03 (Sizes 4" and Larger)
(Full Internal Port)

MODEL

636-03 (Sizes 6" and Larger)
(Reduced Internal Port)

Solenoid Control Valve



- Fast Acting Solenoid Control
- Drip Tight Shut-Off
- Simple Design, Proven Reliable
- Optional Check Feature
- Easy Installation & Maintenance

The Cla-Val Model 136-03/636-03 Solenoid Control Valve is an on-off control valve which either opens fully or closes drip-tight upon receiving an electrical signal to the solenoid pilot control. This valve consists of a Hytrol main valve, a three way solenoid and a high capacity three-way pilot valve. The solenoid control operates the three-way valve which alternately applies pressure to or relieves pressure from the diaphragm chamber of the main valve. It is furnished either normally open (de-energize solenoid to open) or normally closed (energize solenoid to open).

If the check feature option is added and a pressure reversal occurs, the downstream pressure is admitted into the main valve cover chamber and the valve closes to prevent return flow.

Schematic Diagram

Item	Description
1	Hytrol (Main Valve)
2	CS3 Solenoid Control
3	102C-3H Three-Way Valve
4	CNA Needle Valve (Closing)

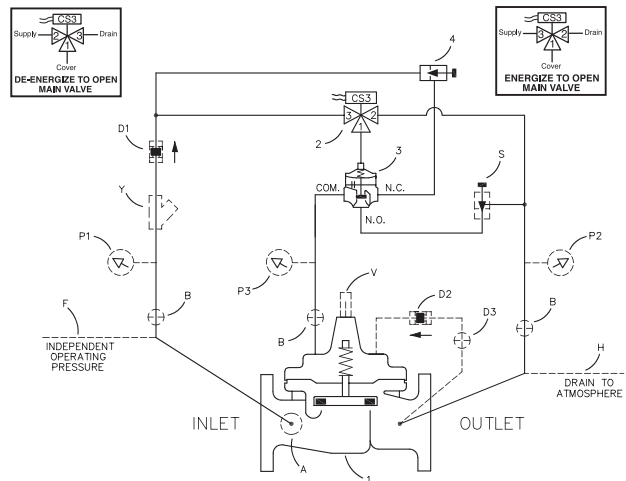

Optional Features

Item	Description
A	X46 Flow Clean Strainer
B	CK2 (Isolation Valve)
D	Check Valves With Isolation Valve
F	Independent Operating Pressure
H	Atmospheric Drain
P	X141 Pressure Gauge
S	CNA Needle Valve (Opening)
V	X101 Valve Position Indicator
Y	X43 "Y" Strainer

Valves 6" and larger with a "D" check feature must be installed with the main valve stem in a vertical position

Typical Applications

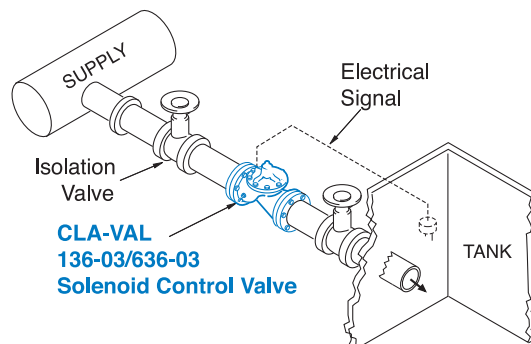
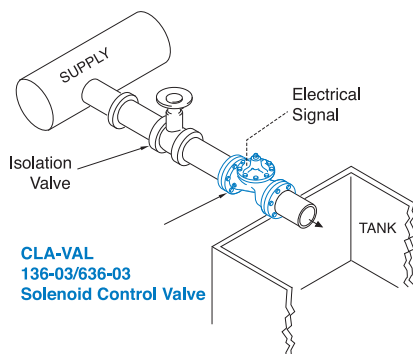

Industrial uses for the solenoid control valve are many and include accurate control of process water for batching, mixing, washing, blending or other on-off type uses.

Liquid level control can be provided by using a float switch or electrode probe which sends an electrical signal to open or close the valve as needed.



Model 136-03 (Uses Basic Valve Model 100-01)

Pressure Ratings (Recommended Maximum Pressure - psi)

Valve Body & Cover		Pressure Class				
		Flanged			Grooved	Threaded
Grade	Material	ANSI Standards*	150 Class	300 Class	300 Class	End‡ Details
ASTM A536	Ductile Iron	B16.42	250	400	400	400
ASTM A216-WCB	Cast Steel	B16.5	285	400	400	400
ASTM B62	Bronze	B16.24	225	400	400	400

Note: * ANSI standards are for flange dimensions only.
 Flanged valves are available faced but not drilled.
 ‡ End Details machined to ANSI B2.1 specifications.
Valves for higher pressure are available; consult factory for details

Materials

Component	Standard Material Combinations		
Body & Cover	Ductile Iron	Cast Steel	Bronze
Available Sizes	4" - 36"	4" - 16"	4" - 16"
Disc Retainer & Diaphragm Washer	Cast Iron	Cast Steel	Bronze
Trim: Disc Guide, Seat & Cover Bearing	Bronze is Standard Stainless Steel is Optional		
Disc	Buna-N® Rubber		
Diaphragm	Nylon Reinforced Buna-N® Rubber		
Stem, Nut & Spring	Stainless Steel		

For material options not listed, consult factory.
 Cla-Val manufactures valves in more than 50 different alloys.

Dimensions
(In inches)

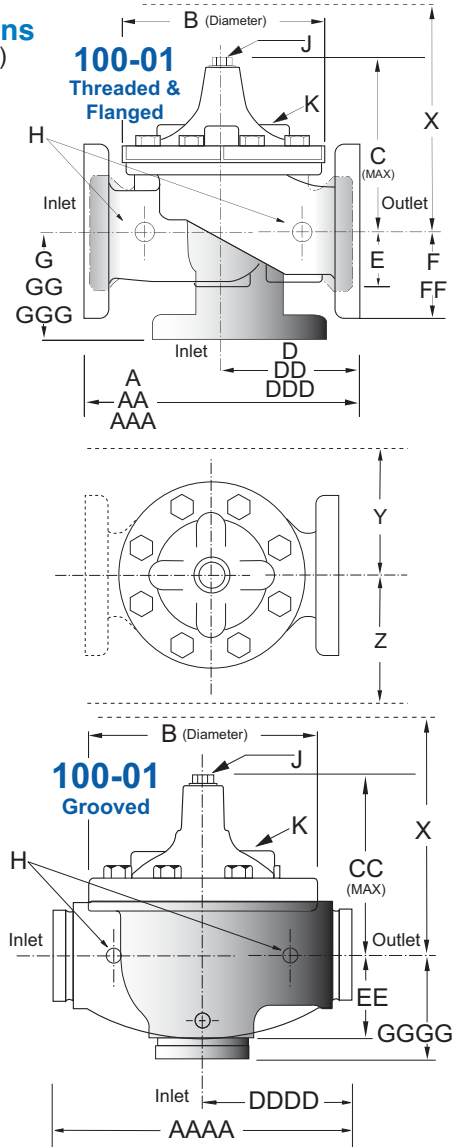

Model 136-03 Dimensions (In Inches)

Valve Size (Inches)	4	6	8	10	12	14	16	18	20	24	30	36
A Threaded	—	—	—	—	—	—	—	—	—	—	—	—
AA 150 ANSI	15.00	20.00	25.38	29.75	34.00	39.00	41.38	46.00	52.00	61.50	63.00	76.00
AAA 300 ANSI	15.62	21.00	26.38	31.12	35.50	40.50	43.50	47.64	53.62	63.24	64.50	76.00
AAAA Grooved End	15.00	20.00	25.38	—	—	—	—	—	—	—	—	—
B Dia.	11.50	15.75	20.00	23.62	28.00	32.75	35.50	41.50	45.00	53.16	56.00	66.00
C Max.	10.62	13.38	16.00	17.12	20.88	24.19	25.00	39.06	41.90	43.93	54.60	61.50
CC Max. Grooved End	9.31	12.12	14.62	—	—	—	—	—	—	—	—	—
D Threaded	—	—	—	—	—	—	—	—	—	—	—	—
DD 150 ANSI	7.50	10.00	12.69	14.88	17.00	19.50	20.81	—	—	30.75	—	—
DDD 300 ANSI	7.88	10.50	13.25	15.56	17.75	20.25	21.62	—	—	31.62	—	—
DDDD Grooved End	7.50	—	—	—	—	—	—	—	—	—	—	—
E	3.19	4.31	5.31	9.25	10.75	12.62	15.50	12.95	15.00	17.75	21.31	24.56
EE Grooved End	4.25	6.00	7.56	—	—	—	—	—	—	—	—	—
F 150 ANSI	4.50	5.50	6.75	8.00	9.50	10.50	11.75	15.00	16.50	19.25	22.50	25.60
FF 300 ANSI	5.00	6.25	7.50	8.75	10.25	11.50	12.75	15.00	16.50	19.25	24.00	25.60
G Threaded	—	—	—	—	—	—	—	—	—	—	—	—
GG 150 ANSI	5.00	6.00	8.00	8.62	13.75	14.88	15.69	—	—	22.06	—	—
GGG 300 ANSI	5.31	6.50	8.50	9.31	14.50	15.62	16.50	—	—	22.90	—	—
GGGG Grooved End	5.00	—	—	—	—	—	—	—	—	—	—	—
H NPT Body Tapping	.75	.75	1	1	1	1	1	1	1	1	2	2
J NPT Cover Center Plug	.75	.75	1	1	1.25	1.5	2	1.5	1.5	1.5	2	2
K NPT Cover Tapping	.75	.75	1	1	1	1	1	1	1	1	2	2
Stem Travel	1.1	1.7	2.3	2.8	3.4	4.0	4.5	5.1	5.63	6.75	7.5	8.5
Approx. Ship Wt. Lbs.	140	285	500	780	1165	1600	2265	2982	3900	6200	7703	11720
X Pilot System	17	29	31	33	36	40	40	43	47	68	79	85
Y Pilot System	12	20	22	24	26	29	30	32	34	39	40	45
Z Pilot System	12	20	22	24	26	29	30	32	34	39	42	47

Note: The top two flange holes on valve size 36 are threaded to 1 1/2"-6 UNC.

Model 636-03 (Uses Basic Valve Model 100-20)

Dimensions
(In inches)

Pressure Ratings (Recommended Maximum Pressure - psi)

Valve Body & Cover		Pressure Class		
		Flanged		
Grade	Material	ANSI Standards*	150 Class	300 Class
ASTM A536	Ductile Iron	B16.42	250	400
ASTM A216-WCB	Cast Steel	B16.5	285	400
ASTM B62	Bronze	B16.24	225	400

Note: * ANSI standards are for flange dimensions only.
Flanged valves are available faced but not drilled.
Valves for higher pressure are available; consult factory for details

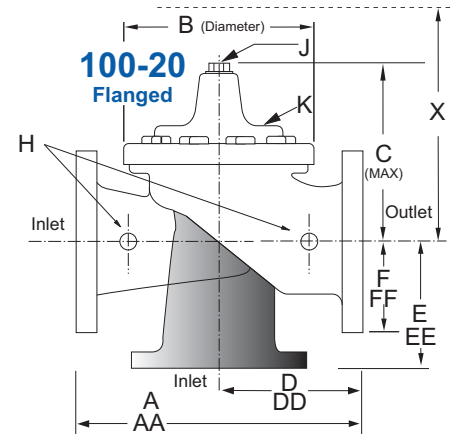

Materials

Component	Standard Material Combinations		
	Ductile Iron	Cast Steel	Bronze
Body & Cover	Ductile Iron	Cast Steel	Bronze
Available Sizes	6" - 48"	6" - 16"	6" - 16"
Disc Retainer & Diaphragm Washer	Cast Iron	Cast Steel	Bronze
Trim: Disc Guide, Seat & Cover Bearing	Bronze is Standard Stainless Steel is Optional		
Disc	Buna-N® Rubber		
Diaphragm	Nylon Reinforced Buna-N® Rubber		
Stem, Nut & Spring	Stainless Steel		

For material options not listed, consult factory.
Cla-Val manufactures valves in more than 50 different alloys.

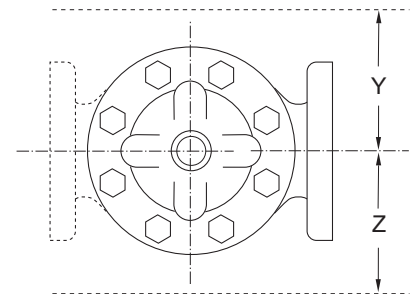

Model 636-03 Dimensions (In Inches)

Valve Size (Inches)	6	8	10	12	14	16	18	20	24	30	36	42	48
A 150 ANSI	17.75	21.38	26.00	30.00	34.25	35.00	42.12	48.00	48.00	63.25	65.00	76.00	94.50
AA 300 ANSI	18.62	22.38	27.38	31.50	35.75	36.62	43.63	49.62	49.75	63.75	67.00	76.00	94.50
B Dia.	11.50	15.75	20.00	23.62	27.47	28.00	35.44	35.44	35.44	53.19	56.00	66.00	66.00
C Max.	11.62	15.00	17.88	21.00	20.88	25.75	25.00	31.00	31.00	43.94	54.60	61.50	61.50
D 150 ANSI	8.88	10.69	CF*	CF*	CF*	CF*	CF*	CF*	CF*	—	—	—	—
DD 300 ANSI	9.38	11.19	CF*	CF*	CF*	CF*	CF*	CF*	CF*	—	—	—	—
E 150 ANSI	6.75	7.25	CF*	CF*	CF*	CF*	CF*	CF*	CF*	—	—	—	—
EE 300 ANSI	7.25	7.75	CF*	CF*	CF*	CF*	CF*	CF*	CF*	—	—	—	—
F 150 ANSI	5.50	6.75	8.00	9.50	11.00	11.75	15.88	14.56	17.00	19.88	25.50	28.00	31.50
FF 300 ANSI	6.25	7.50	8.75	10.25	11.50	12.75	15.88	16.06	19.00	22.00	27.50	28.00	31.50
H NPT Body Tapping	.75	.75	1	1	1	1	1	1	1	1	2	2	2
J NPT Cover Center Plug	.75	.75	1	1	1.25	1.25	2	2	2	2	2	2	2
K NPT Cover Tapping	.75	.75	1	1	1	1	1	1	1	1	2	2	2
Stem Travel	1.1	1.7	2.3	2.8	3.4	3.4	4.5	4.5	4.5	6.5	7.5	8.5	8.5
Approx. Ship Wt. Lbs.	195	330	625	900	1250	1380	1500	2551	2733	6500	8545	12450	13100
X Pilot System	27	30	33	36	36	41	40	46	55	68	79	85	86
Y Pilot System	18	20	22	24	26	26	30	30	30	39	40	45	47
Z Pilot System	18	20	22	24	26	26	30	30	30	39	42	47	49

*Consult Factory

Note: The top two flange holes on valve sizes 36 thru 48 are threaded to 1 1/2"-6 UNC.

136-03 Valve Selection	100-01 Pattern: Globe (G), Angle (A), End Connections: Threaded (T), Grooved (GR), Flanged (F) Indicate Available Sizes												
	Inches	4	6	8	10	12	14	16	18	20	24	30	36
	mm	100	150	200	250	300	350	400	450	500	600	750	900
Basic Valve 100-01	Pattern	G, A	G, A	G, A	G, A	G, A	G, A	G, A	G	G	G, A	G	G
	End Detail	F, Gr	F, Gr*	F, Gr*	F	F	F	F	F	F	F	F	F
Suggested Flow (gpm)	Maximum	800	1800	3100	4900	7000	8400	11000	14000	17000	25000	42000	50000
	Maximum Intermittent	990	2250	3900	6150	8720	10540	13700	17500	21700	31300	48000	62500
Suggested Flow (Liters/Sec)	Maximum	50	113	195	309	442	530	694	883	1073	1577	2650	3150
	Maximum Intermittent	62	142	246	387	549	664	863	1104	1369	1972	3028	3940

100-01 Series is the full internal port Hytrol.

*Globe Grooved Only

636-03 Valve Selection	100-20 Pattern: Globe (G), Angle (A), End Connections: Flanged (F) Indicate Available Sizes													
	Inches	6	8	10	12	14	16	18	20	24	30	36	42	48
	mm	150	200	250	300	350	400	450	500	600	750	900	1000	1200
Basic Valve 100-20	Pattern	G, A	G, A	G	G	G	G	G	G	G	G	G	G	G
	End Detail	F	F	F	F	F	F	F	F	F	F	F	F	F
Suggested Flow (gpm)	Maximum	1025	2300	4100	6400	9230	9230	16500	16500	16500	28000	33500	33500	33500
Suggested Flow (Liters/Sec)	Maximum	65	145	258	403	581	581	1040	1040	1040	1764	2115	2115	2115

100-20 Series is the reduced internal port size version of the 100-01 Series.

Pilot System Specifications

Temperature Range

Water: to 180°F

Fluids

Air, water, light oils

Rubber Parts:

Buna-N® Synthetic Rubber

Solenoid Control

Body:

Brass ASTM B283

Enclosure:

NEMA Type 1,2,3,3S,4,4X general purpose watertight*

NEMA Type 6,6P,7,9 watertight Explosion Proof available.

Voltages:

110, 220 - 50Hz AC

24, 120, 240, 480 - 60Hz AC

6, 12, 24, 120, 240 - DC

Others available at additional cost

Max. operating pressure differential:

200 psi*

Coil:

Insulation molded Class F

Watts AC 6

AC Volt Amps Inrush 30

AC Volt Amps Holding 16

Watts DC 10.6

Manual operator available at additional cost.

*Supplied unless otherwise specified

Note: Flowing Pressure Differential: 5 psi minimum

When Ordering, Please Specify

1. Catalog No. 136-03 or No. 636-03
2. Valve Size
3. Pattern - Globe or Angle
4. Pressure Class
5. Threaded or Flanged
6. Materials Desired
7. Energized or de-energized to open Main Valve
8. Solenoid Enclosure, Voltage & Hertz, Coil Insulation, and Max. Operating Pressure Differential
9. Desired Options
10. When Vertically Installed