



## PRODUCT SPECIFICATION SHEET

The Condensate Handler™ is the newest Drain•All model and replaces the Model 1700™. This is the flagship condensate trap in the Drain•All product family. The Condensate Handler™ includes Drain•All's patented "through-port" design for increased capacity for handling of solid debris.



### KEY FEATURES

- Will fit most industrial applications and compressors up to approximately 1500 hp
- Is an industrially robust unit with fewer moving parts than competitive traps so it can stand up to the most demanding applications with minimal maintenance
- Requires no electrical connections and can easily be installed with plant personnel on equipment at any point in an air system
- Is a high quality product produced under an ISO 9001:2008 certified quality system
- Options and accessories are available for drain trap customization
- Drain•All engineers available to help develop engineered solutions and installation guidance
- Is backed by an excellent factory warranty

## NEW CONDENSATE HANDLER™

Catalog #870700

#### Patented "through-port" design

The new Condensate Handler™ includes Drain•All's patented "through-port" design that provides increased capability for handling of solid debris. This provides increased reliability in applications with heavy rust and debris that may clog other traps. This means smooth trouble free operation and fewer maintenance hassles.

#### Environmentally safe "Green Product"

Drain•All traps are environmentally friendly green products that are totally pneumatic and don't require electricity for operation. This helps minimize and reduce total plant wide energy costs. Bottom line, Drain•All traps can save on operating costs.

#### Corrosion resistant materials & fewer parts

The Condensate Handler™ is manufactured using corrosion resistant materials and has the fewest moving parts when compared to some competitive pneumatic traps. This provides for less maintenance and longer life. Total life cycle cost can be significantly lower with a Drain•All trap.

#### Automatic design

The Condensate Handler™ works on demand as liquid accumulates in the reservoir. It's fully automatic. Once installed, no daily maintenance or on-going adjustments are required. This saves on the constant need for maintenance attention and additional labor.

#### Easy to Install

Because all Drain•All traps are completely pneumatic, installation is simple and can be made anywhere along the compressed air system. Installation can be flexible including in remote facilities, explosion-risk areas, or hard-to-reach points along the system where electricity is not available. This saves on installation time, materials, and labor.

#### Flow Control Solutions from Control Devices, LLC



Drain•All has joined the family of flow control solutions offered by Control Devices. Control Devices is a global manufacturer with an excellent reputation in the air compressor, pressure washer, fire suppression, vehicle systems, industrial float valve and specialty gas markets.





# PRODUCT SPECIFICATION SHEET

**How DRAIN•ALL works...**  
It's simple and efficient.

 CONTROL AIR  
 LIQUID

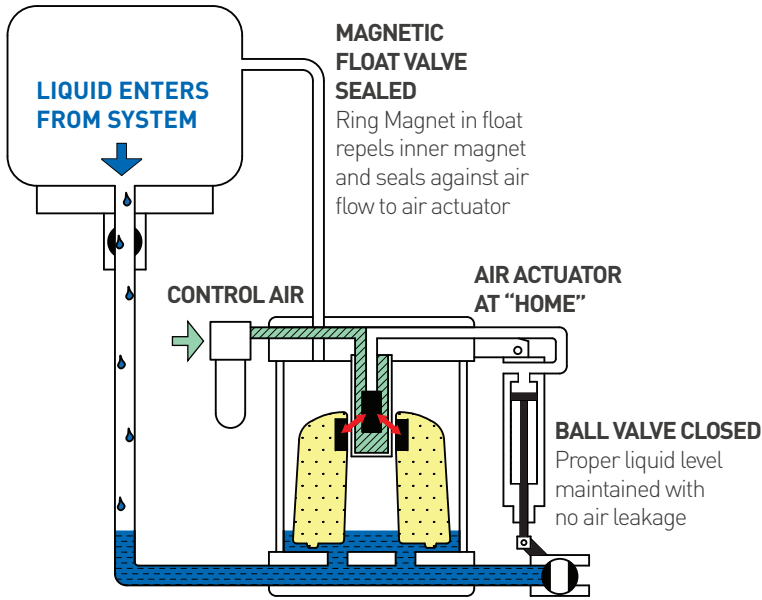

**FIGURE 1**

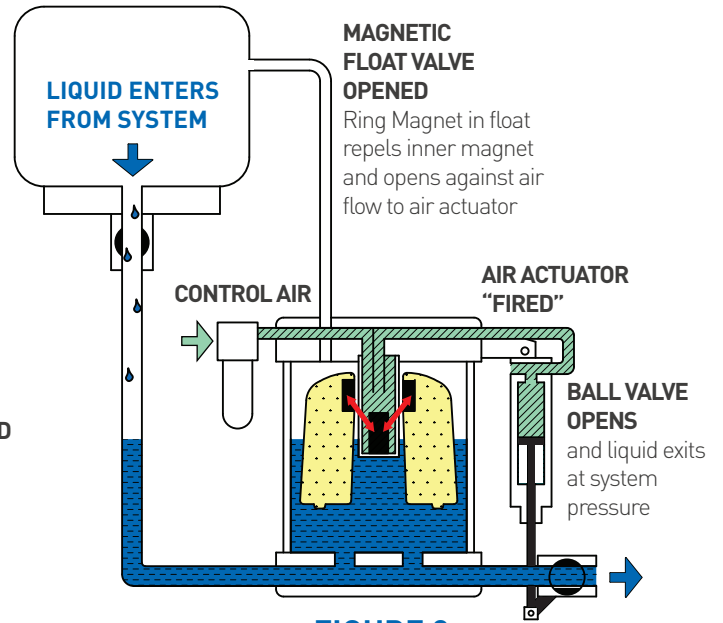

**FIGURE 2**

## FIGURE 1: START OF CYCLE

The polymer float with integral magnet is resting on the base of the reservoir. The integral float magnet exerts a magnetic force repelling the inner magnet upward and holding it seated against an orifice in the lower end of the control air valve stem. The control air circuit, including the inner magnet and valve stem, is isolated from liquid that flows into the reservoir. The air actuator is in the home position and the discharge ball valve is closed.

## FIGURE 2: START OF DISCHARGE

Liquid continues to flow into the reservoir and raises the float to its highest position. The integral float magnet is then raised up past the inner magnet and repels the inner magnet downward opening the orifice in the control air valve stem. This allows the control air from the center tube to flow through to the other side of the control air circuit to the air actuator. Control air pressure extends the air actuator and opens the ball valve starting the discharge of the liquid accumulated in the reservoir.

### Condensate Handler Catalog #870700 Specifications & Dimensions

Max Liquid Temp - °F (°C)	170 (76.7)
Max Liquid Pressure - psig (barg)	170 (11.7)
Control Air Min - psig (barg)	40 (2.8)
Control Air Max - psig (barg)	130 (9.0)
Ht - inches (cm)	11 (27.9)
Width - inches (cm)	9-1/4 (23.5)
Depth (Inlet/BV) - inches (cm)	10-1/2 (26.7)
Inlet/Outlet - NPT	1/2"
Control Air - NPT	1/4"
Balance Line - NPT	1/8"
Capacity	Based on pressure/piping
Weight - lbs (kg)	21 (9.5)

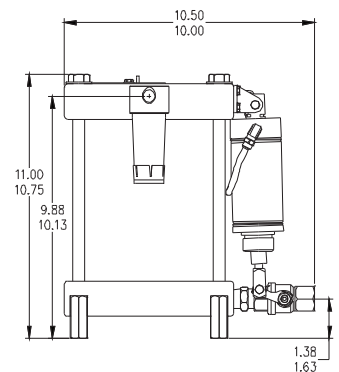
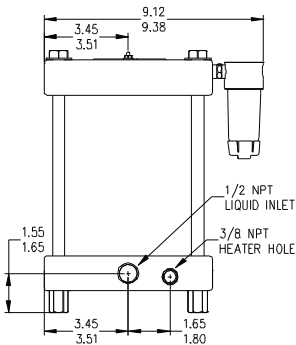

**drain-all.com**  
E-mail: [Info@drain-all.com](mailto:Info@drain-all.com)  
PO Box 609  
1170 Topside Rd  
Louisville, TN 37777  
Phone: 865.970.9290 Fax: 865.977.6658

Another engineered  
flow control solution from

