

Pump Control Panel



Components

- **Pre-programmed Logic Controller**
- **Simplifies Field Wiring Installation**
- **Indicator Lights Monitor System Status**
- **Completely NEMA 4X Rated**
- **Suitable for all Booster Pump and Deep Well Applications**

The Cla-Val PC-1 provides control of the pump and pump control valve preventing surges in the system when the pump starts or stops. It consists of a pre-wired electric control panel employing a programmable logic controller to sequence the pump and pump control valve during all modes of operation. The programmable logic controller which is housed in a NEMA 4X rated enclosure provides protection to the pumping system from damage due to mechanical, hydraulic or power failure. The PC-1 offers all the control features found in the Cla-Val recommended wiring diagrams, plus alarms, automatic shutdown and adjustable timers.

Externally mounted indicator lights provide local visual indication of normal operation and alarm conditions. These lights indicate a total of eleven normal operation and alarm conditions. The three position "Hand-Off-Auto" switch provides local or remote pump start/stop operation. The PC-1 is supplied with contacts for a pressure switch and an, "Anti-Plugging" switch. The Cla-Val PC-1 Pump Control Panel is manufactured to insure a minimum amount of wiring in the field. It is pre-programmed for most common pump control applications.

Features

- Controls single and dual chambered pump control valves
- Local visual indication of pump and control valve status
- Contacts for remote indication of emergency conditions
- Easy to adjust sequence timers
- Contacts provided for remote or automatic start signal
- Operator interface buttons include lamp test and reset switch
- Easy field wiring installation
- Automatic shutdown of pump in emergency situations
- Terminal block connections include — solenoid controls, valve limit switch, pump starter relays, remote automatic starters, remote alarm signals, pressure switch, "Auto" position remote indication and "Anti-Plugging" contacts.
- HOA switch for local automatic or manual operation

Typical Applications

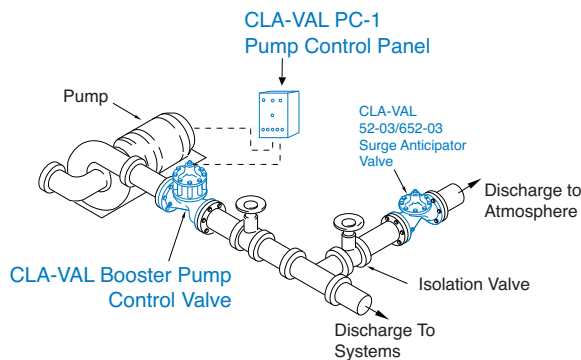

To minimize "in field wiring" the PC-1 is manufactured for most common pump control applications. The installation above shows the PC-1 being used with a Cla-Val Booster Pump Control Valve.

Wiring Diagram

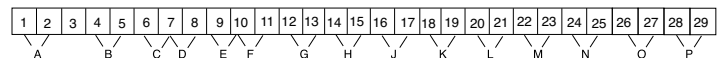

- A. 120 VAC Power Input
- B. Motor Starter Contacts (10 Amp Fused)
- C. Emergency Closing Solenoid (120 VAC)
- D. Pilot Valve Solenoid (120 VAC)
- E. Pressure Switch (N.O.) Customer supplied
- F. Valve Limit Switch (N.O.)
- G. Remote/Automatic Start
- H. Loss of Power Restart (Jumper installed enables restart)
- J. Failure to develop pressure - Remote alarm (non-powered)
- K. Loss of Pressure - Remote Alarm (non-powered)
- L. Valve Failed to Open - Remote Alarm (non-powered)
- M. Valve Reclosed - Remote Alarm (non-powered)
- N. Loss of Power Restart Delay - Remote Alarm (120 VAC)
- O. H-O-A switch in Auto position- Remote Contacts (Non-Powered)
- P. Anti-Plugging Pump Contacts (N.O.)

Operation

The PC-1 pump control panel functions as a pump starter controller and pump control valve sequencer and provides appropriate visual indication of system status throughout all modes of operation.

Colored lights are provided to indicate normal operation and alarm conditions of the pump and control valve.

Visual Indications

1. **White** — 120 VAC power is available to the panel.
2. **Flashing blue** — pump start command and initiation of Pressure Delay Sequence (PDS)
3. **Steady blue** — pump discharge pressure has reached a proper level.
4. **Flashing green** — Pilot Valve Solenoid (PVS) is energized and initiation of the Valve Sequence Timer (VST).
5. **Steady green** — valve open.
6. **Steady yellow** — loss of power-automatic restart disabled.
7. **Flashing yellow** — loss of power-automatic restart shutdown.
8. **Flashing red with flashing blue** — failure to develop pressure on start-up.
9. **Flashing red with steady blue** — loss of pressure shutdown
10. **Flashing red with flashing green** — failure of control valve to open on start-up.
11. **Flashing red with steady green** — valve closure without command.

Normal Pump Start (Hand or Auto)

A pump start command is initiated by turning the HOA switch to the "Hand" position and pressing start or by a remote contact closure with the HOA switch in the "Auto" position; either of these operations will cause the PC-1 to initiate pump start.

A white light indicates that 120 VAC power is available to the PC-1 (visual indication #1). The pump starts and a flashing blue indicator light is displayed. The pressure delay sequence (PDS) will be initiated simultaneously with the pump start (visual indication #2). The flashing blue light will be displayed until pump discharge pressure exceeds static system head (pre-set on the pumps discharge pressure switch) or until the PDS expires.

A flashing red with flashing blue light indicates a failure of the pump to produce sufficient pressure to satisfy the pressure switch setting within the PDS time frame (visual indicator #8). Should this occur, motor starter contacts shall open de-energizing the pump motor. A manual "reset" of the HOA switch is required to restart the pump. A steady blue light indicates that the pump discharge pressure has reached a desired pressure (visual indication #3).

Upon reaching discharge pumping pressure and PDS completion, a flashing green light indicates the solenoid on the pump control valve is energized and the start of the valve sequence timer (VST) (visual indication #4). The flashing green light is displayed until the valve opens and actuates the limit switch, or until the VST expires.

A flashing red with flashing green light indicates failure of the control valve to open on start up (visual indication #10), motor starter contacts will open, de-energizing the pump motor. A manual "reset" of the HOA switch is required to restart the pump.

A steady green light indicates the pump control valve opens and trips the limit switch prior to expiration of the VST (visual indication #5.) The steady green light is displayed for the duration of the pumping operation.

Normal Pump Shutdown

A normal pump shutdown sequence is initiated by either depressing the stop button or by remotely breaking contacts of the remote start circuit with the HOA switch in the "Auto" position. The solenoid pilot on the pump control valve is de-energized to initiate a normal valve closure.

At a pre-set position the pump control valve will actuate the limit switch which opens the motor starter contacts and de-energizes the pump. When the pump control valve is closed and the pump de-energized, the steady green light will be extinguished.

Pump Malfunction

Anytime during the pumping operation when the pump discharge pressure is not capable of satisfying the pressure switch setting, a flashing red with steady blue light will appear (visual indication #9). This indicates a loss of pressure shutdown, the solenoid pilot(s) on the pump control valve will de-energize to close the valve and the pump motor contacts will open to turn off the pump motor. A manual "reset" of the HOA switch is required to restart the pump.

Valve Malfunction

If the solenoid pilot(s) of the pump control valve fail, or if any other event should cause the valve to close without a normal pump shutdown command, a flashing red with steady green light will be displayed (visual indication #11) indicating valve closure without command. The pump motor contacts open to turn off the pump motor. A manual "reset" of the HOA switch is required to restart the pump.

Power Failure

In the event of a power failure, even momentary, a pre-set time delay period is initiated as soon as power is restored which is indicated by a flashing yellow light (visual indication #7). The adjustable time delay period ranges from instantaneous to ten (10) hours. During the power failure delay period, it is not possible to have an automatic pump restart. After the delay period has expired, a normal pump start sequence is initiated if a local or remote pump start command exists. It is possible to cancel the delay period by a manual reset of the HOA switch. A steady yellow light indicates a loss of power-automatic restart disabled (visual indication #6). A manual reset of the HOA switch is required to restart the pump.

Note: The customer supplied pressure switch must be installed in order for the pump discharge shutdowns to function.

Specifications

Power Required

120 Volt 60Hz AC,
5 Amps

Loss of Power Remote Alarm

120 Volt 60Hz AC output

Motor Starter Contacts

10 Amp Fused

Solenoid Controls on Valve

120 Volt 60Hz AC output

Remote Alarm Output Dry Contacts

1 Amp

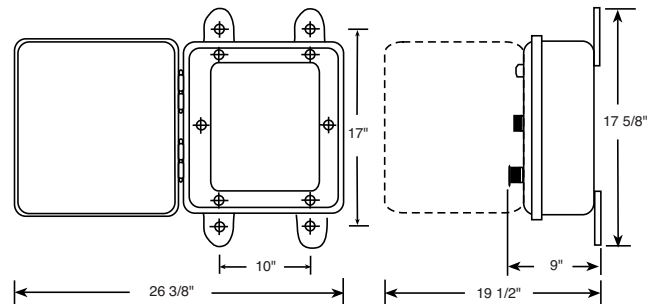

E-PC-1 (R-3/2011)

CLA-VAL

PO Box 1325 Newport Beach CA 92659-0325
Phone: 949-722-4800 • Fax: 949-548-5441

CLA-VAL CANADA

4687 Christie Drive
Beamsville, Ontario
Canada L0R 1B4
Phone: 905-563-4963
Fax: 905-563-4040

CLA-VAL EUROPE

Chemin des Mesanges 1
CH-1032 Romanel/
Lausanne, Switzerland
Phone: 41-21-643-15-55
Fax: 41-21-643-15-50

©COPYRIGHT CLA-VAL 2011 Printed in USA
Specifications subject to change without notice.

www.cla-val.com

Represented By: