

Pre-engineered Systems

Single pump

Pre-engineered solutions!



ProMinent®

ProMinent® is your sole source provider for complete chemical metering systems. The heart of every system is the metering pump. ProMinent® metering pumps are the best engineered and most reliable in today's market. In addition, every system is engineered and designed from the ground up.

ProMinent® offers a variety of pre-engineered chemical feed and control systems.

Pre-engineered systems are fully assembled and tested; guaranteeing a fully functional and high quality system package upon delivery.

*Single pump designs accommodate **beta®**, **gamma/ L**, **delta®**, and **sigma** series pumps. Feed rates up to 264 gph (1000 l/h).*

Features & Benefits

- Plug & Play for quick and easy installations
- Lead times as short as 1-3 weeks
- Designs for handling off-gassing chemicals
- Easy access to pump liquid end for on-site repair and retrofitting
- Optional UL listed and labelled control panels (US)
- Proven design based on 10+ years of experience

Pre-engineered Systems

Single pump

Solutions that work!

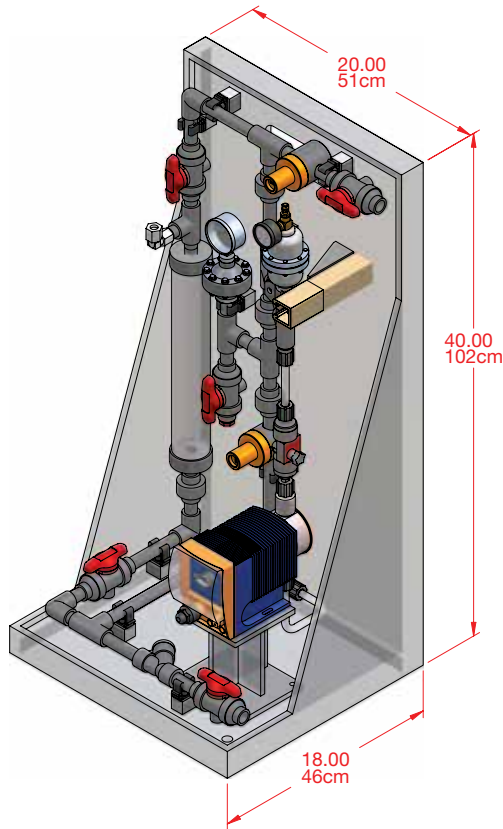

SS1: for Beta[®], Gamma/ L, and delta[®] series pumps

Drawings depict item #4 described below

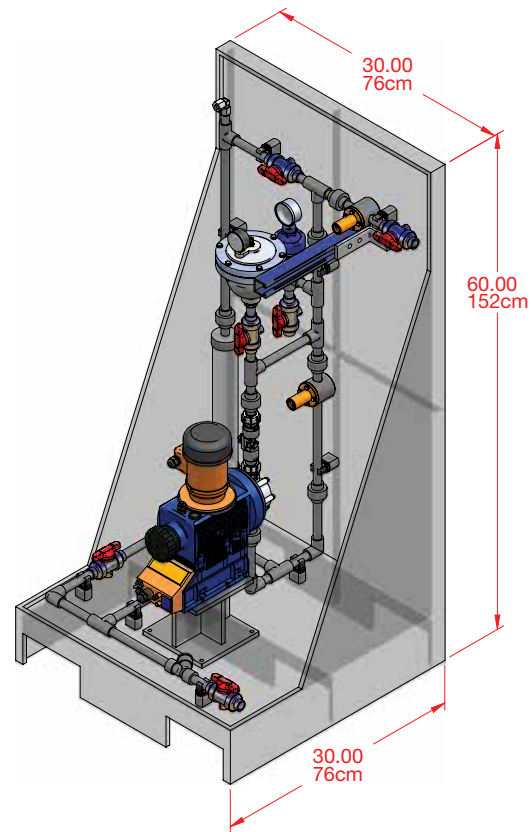

MS1: for Sigma/ 1, Sigma/ 2 and Sigma/ 3 series pumps

Standard Skid Packages, Sizes and Material Configurations

Standard Skid Packages:

1. Wye Strainer, Calibration Column, Backpressure Valve, Pressure Relief Valve, Pressure Gauge (motor skids must have dampener)
2. ALL OF THE ABOVE + Flow Monitor
3. ALL OF THE ABOVE + Pulsation Dampener
4. ALL OF THE ABOVE + Flow Monitor & Pulsation Dampeners

Sizes:

- SS1: 1/2" MNPT
- MS1: 1/2" MNPT
3/4" MNPT
1" MNPT
1-1/2" MNPT

Materials:

- PVC/Viton[®] (socket weld)
- PVC/EPDM (socket weld)
- CPVC/Viton[®]/Vented (socket weld)
- PVDF/PTFE (fusion weld)