

Remote Control Valve



Specifications

Sizes:	1-3 inch Threaded
End Details:	125 ASA B16.1
Pressure Rating:	125 Class-175 psi Max.
Temperature Range:	Water : 125°F Max. Petroleum Products: -40°F to 125°F Max

Material Specification

Main Body and Cover:	Cast Iron ASTM A-48 NSF-61 Epoxy Coating Standard
Main Valve Trim:	Delrin (DuPont 500) with Bronze seat (ASTM B-61)
Spring:	Stainless Steel AISI 302
Diaphragm and Disc:	Buna-N [®] Synthetic Rubber

- Packless design--no lubrication
- Precisely engineered--close drip-tight
- Full line-sized opening--low flow resistance
- No internal or external orifice
- Diaphragm is fully supported for longer life
- Movable parts & seat ring replaceable without removing valve from line
- Fusion Bonded Epoxy Coating Standard

The Cla-Val Model 7100 Valve is a diaphragm actuated, hydraulically operated valve designed for low original cost and long life. Simple, rugged construction allows the 7100 to perform dependably under the most severe operating conditions. Its compact design makes it easy to install.

The 7100 Valve is ideal for any application where the need is for On-Off control, the controlling medium of which is usually the liquid itself, passing through a remote control. The control pressure, when applied against the flexible diaphragm, produces a drip-tight seal between the valve disc and its seat. In the open position, the diaphragm assembly lifts to provide full flow.

The 7100 Valve provides all the advantages of an automatic control valve at a cost comparable to manual valves of the same size and quality.

Purchase Specification

Valve shall be full line size, diaphragm actuated. It shall be hydraulically operated by employing the fluid flowing through it to open as well as close the valve. The diaphragm shall be fabricated of nylon reinforced synthetic rubber, and shall be fully supported in both the open and closed positions and not be used as a disc or seating element. There shall be no packing glands, internal orifice, or continuous bleeding. The body and cover shall be NSF-61 Epoxy Coated inside and out.

The disc shall be synthetic rubber and have a cross section retained on 31/2 sides. The disc shall close drip-tight against the valve seat. The seat ring shall be replaceable and all necessary repairs shall be possible without removing valve from the line. Valve shall be similar in all respects to the Model 7100 Valve as manufactured by Cla-Val, Newport Beach, California, or approved equal.

Principle of Operation

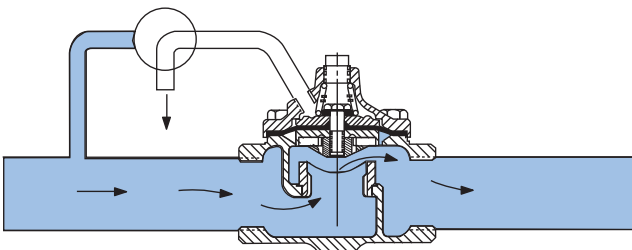

VALVE OPEN

When pressure in diaphragm chamber is relieved to a zone of lower pressure (usually atmosphere) the line pressure at the valve seat opens the valve.

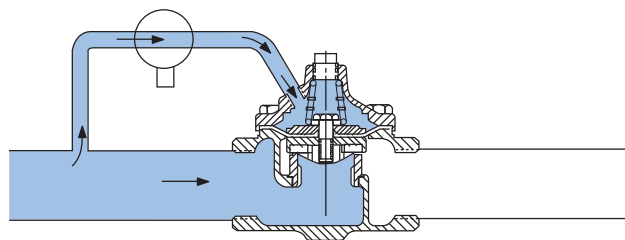

VALVE CLOSED

When pressure from the valve inlet (or an equivalent independent operating pressure) is applied to the diaphragm chamber the valve closes drip-tight.

Dimensions

Valve Size (inches)	1	1 1/4	1 1/2	2	2 1/2	3
A 125 Threaded	4 1/8	5 1/4	5 1/4	6 1/2	7 3/8	8 1/4
B MAX.	3	4	4	4 7/8	5 1/2	6 1/8
C	1 1/2	1 7/8	1 7/8	2 1/2	3	3
D	3	4	4	4 7/8	5 3/4	6 1/2
E NPT	1/4	1/4	1/4	3/8	3/8	3/8
G NPT	3/8	1/2	1/2	1/2	1/2	1/2
K NPT	1/4	1/4	1/4	1/4	1/4	1/4

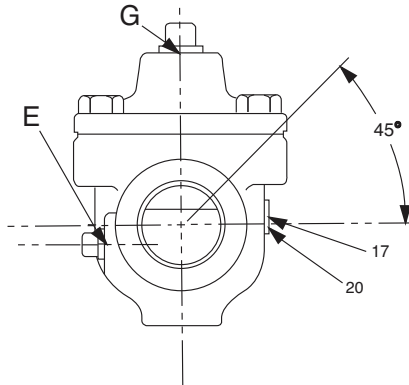
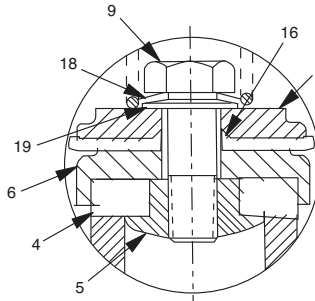
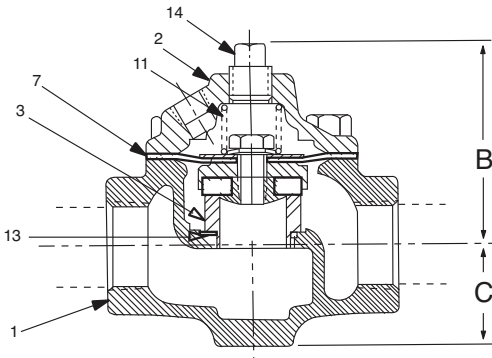
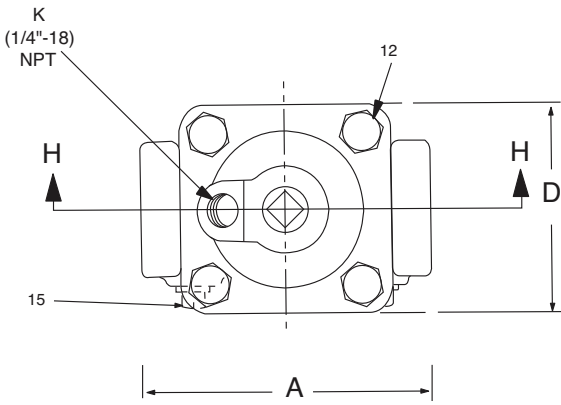

Liquid Volume Displaced from Diaphragm Chamber when Valve Opens

Valve Size	Displacement
1"	.0034 Gals.
1 1/4" & 1 1/2"	.0045 Gals.
2"	.020 Gals.
2 1/2"	.035 Gals.
3"	.055 Gals.

Lower inlet pressure will have slightly less capacity -- Higher pressure slightly more due to diaphragm flexibility

Parts List

Item No.	Description	Qty.
1.	Body	1
2.	Cover	1
3.	Seat	1
4.	Disc	1
5.	Guide, Disc	1
6.	Retainer Disc	1
7.	Diaphragm	1
8.	Washer, Diaphragm	1
9.	Bolt, Stem	1
10.	Nut, Hex	1
11.	Spring	1
12.	Bolt Hex Hd.	4
13.	O-Ring	1
14.	Plug, Pipe	1
15.	Plug, Pipe	1
16.	O-Ring	1
17.	Screw Drive	2
18.	Washer, Bellville	1
19.	Washers	1
20.	Nameplate	1

When Ordering, Please Specify

- Catalog No.7100
- Valve Size
- Number of valves required

Variations Available

Catalog No.	Description of Variable
7100 KH	Equipped with heavy spring
7100 KR	7100KH arranged for reverse flow
7100 KX	Equipped with extra heavy spring

Flow Characteristics

The clean, full-throated design of the Model 7100 VALVE provides minimum pressure loss and optimum C_v factors for all valve sizes.

$$C_v = \frac{\text{Flow Rate in GPM}}{\sqrt{\text{Pressure Loss in psi}}}$$

Valve Size	C_v Factor	Pressure Loss in psi With Valve Wide Open																
1"	13	.14	.6	1.3	2.3	5.1	9.2	14.5	21.									
1 1/4"	23			.18	.42	.74	1.7	3.0	4.7	6.7	12.0	18.8						
1 1/2"	25			.17	.38	.66	1.5	2.7	4.2	6.0	10.5	16.8						
2"	46					.19	.4	.8	1.2	1.7	3.0	4.7	10.5	18.8				
2 1/2"	72							.17	.4	.5	.7	1.3	1.9	4.4	7.6	17.0		
3"	106									.14	.2	.3	.6	.9	2.0	3.5	8.0	14.5
		5	10	15	20	30	40	50	60	80	100	150	200	300	400			
Flow of Water -- Gallons Per Minute																		



E-7100 (R-11/2015)

CLA-VAL

1701 Placentia Ave. Costa Mesa, CA 92627-4475
Phone: 949-722-4800 • Fax: 949-548-5441

CLA-VAL CANADA
4687 Christie Drive
Beamsville, Ontario
Canada L0R 1B4
Phone: 905-563-4963
Fax: 905-563-4040

CLA-VAL EUROPE
Chemin des Mesanges 1
CH-1032 Romanel/
Lausanne, Switzerland
Phone: 41-21-643-15-55
Fax: 41-21-643-15-50

©COPYRIGHT CLA-VAL 2015 Printed in USA
Specifications subject to change without notice.

www.cla-val.com

Represented By: