

Mark 60 Series

Self Operated Pressure Regulators

The Mark 60 Sliding Gate Pressure Regulator is used to regulate the downstream pressure to a predetermined setpoint. The spring in the Mark 60 holds the sliding gate seats in their normally open position to allow the process media to pass through the seats.

The downstream pressure is sensed beneath the diaphragm. **(A sensing line is required on sizes: 2-1/2", 3", and 4")**. As the downstream pressure exceeds the setpoint, pressure is exerted on the diaphragm which raises the stem to modulate the disc (the moveable component on the sliding gate seat set) toward the closed position. As the seats close, downstream pressure will be reduced to the required setpoint. A decrease in pressure relaxes the spring and diaphragm to move the seats toward the open position.

This brochure includes the following Series:

- **MK60:** a line of self-operating pressure regulators designed with Jordan Valve's sliding gate seats
- **MK61:** The MK61 features a larger diaphragm than a standard MK60 to provide even greater sensitivity and minimum offset from a required setpoint
- **MK60QC:** The MK60QC features a "Quick Change" dome for simple range spring replacements. Ideal for facilities with multiple pressure reducing applications - stock one valve with several spare springs to cover a wide range of needs
- **MK60H:** The MK60H features a handwheel that replaces the adjusting screw for easy changes to the setpoint
- **MK60HP:** Working pressure fully rated to ANSI Class 600 pressures, the HP options permits setpoints as high as 450 psi
- **MK60GP:** The MK60GP option requires grain processing modification for starch cookers and other viscous services
- **MK601/602:** The MK601 and MK602 meet higher capacity requirements than standard regulators



Mark 60 Features

- **Sliding Gate Trim** – unique seat design for unsurpassed trim life and accuracy
- **Jorcote Seat Coating** – ceramic composite for liquids, gases and especially steam. Very low friction with outstanding wear resistance and a temperature rating of up to 550°F. Steam tested to 1,000,000 cycles and still maintained Class IV leakage.
- **Jorlon Diaphragm** – extremely durable, virtually universally applicable up to 450°F. Tested without failure to over 1,000,000 full stroke cycles. Ideal for steam, gases and liquids. 316SST diaphragm applicable up to 550°F.
- **Straight-through Flow** – The flow is straight through the valve seats and body. Direction of the disc travel is perpendicular to the flow, not opposed to the direction of the flow. Thus, the flow does not unbalance the seats. The MK60 can use a wider range of its stroke to give accurate control; less offset
- **Quiet Operation** – typically 5-10 dB less than conventional globe style regulators. The disc and plate are always in contact, which eliminates chattering. Straight-through flow minimizes turbulence. Multiple orifices in the plate and disc divide the flow stream into smaller flow components
- **Minimum Maintenance** – The MK60 sliding gate seats require no special tools for disassembly. The seats are pre-lapped at the factory and are self-lapping while in operation ensuring a continual tight shutoff

FEATURES & BENEFITS

Ideal for gas and liquids
Superior for steam

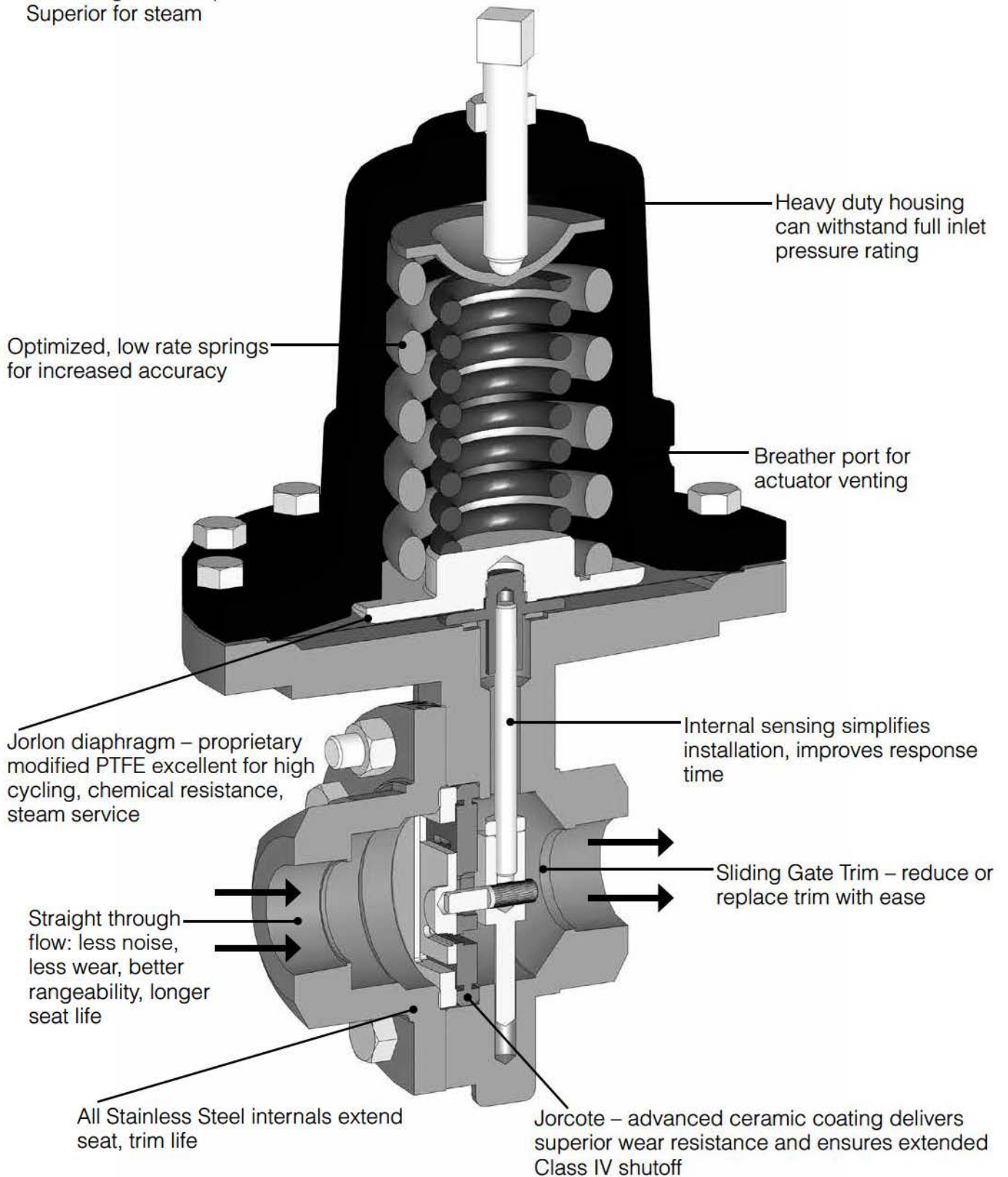

SPECIFICATIONS – MK60/60QC/61/60HP

Sizes: (note: 1/4" & 3/8" sizes use 1/2" body with reducers)

- Mark 60: 1/4" – 4" (DN8 – DN100)
- Mark 60QC: 1/4" – 2" (DN8 – DN50)
- Mark 61: 1/4" – 3/4" (DN8 – DN20)
- Mark 60HP: 1/4" – 4" (DN8 – DN100)

End Connections:

- Threaded – FNPT, BSPT, BSPP (1/2" – 2" only)
- ANSI Flanges (150#, 300#)
- DIN Flanges (PN 10/16, PN 25/40)

Spring Housing:

- CI or DI – 1/4" – 2" (DN8 – DN50)
- DI/Steel – 2-1/2" – 4" (DN65 – DN100)

Body Materials:

- Ductile Iron
- Bronze (1/2" – 2"; DN15 – DN50)
- Carbon Steel (A216 WCB)
- Stainless Steel (A351/CF8M)

Trim Materials:

- 303SST – Standard on Ductile Iron, Bronze, Carbon Steel valves
- 316SST – Standard on Stainless Steel valves
- Monel, Hastelloy and other Alloys available

Reduced Pressure Control Ranges: Select a range to match your setpoint. For optimal performance, your setpoint should fall in the upper portion of the selected range.

Model	Size (DN)	Spring Ranges	
		PSI	Bar
60 & 60QC	1/4" – 3/4" (DN8 – DN20)	2 – 23	0,14 – 1,6
		10 – 38	0,69 – 2,6
		20 – 55	1,4 – 3,8
		30 – 85	2,1 – 5,9
		35 – 160	2,4 – 11,0
		95 – 220	6,6 – 15,2
	1" – 2" (DN25 – DN50)	1 – 5	0,07 – 0,34
		3 – 8	0,21 – 0,55
		5 – 20	0,34 – 1,4
		10 – 30	0,69 – 2,1
		20 – 45	1,4 – 3,1
		30 – 95	2,1 – 6,6
	2-1/2" – 4" (DN65 – DN100)	60 – 160	4,1 – 11,0
		7 – 18	0,48 – 1,2
		10 – 25	0,69 – 1,7
60HP	1/2" – 2" (DN15 – DN40)	15 – 35	1,0 – 2,4
		75 – 190	5,2 – 13,1
		100 – 320	6,9 – 22,1
	2-1/2" – 4" (DN65 – DN100)	150 – 450	10,3 – 31,0
		30 – 75	2,07 – 5,17
		65 – 110	4,5 – 7,6
61	1/4" – 3/4" (DN8 – DN20)	1 – 5	0,07 – 0,34
		2 – 12	0,14 – 0,83
		2 – 25	0,14 – 1,7
		10 – 35	0,69 – 2,4
		20 – 55	1,4 – 3,8
		20 – 80	1,4 – 5,5
		40 – 115	2,8 – 7,9
		25 – 160	1,7 – 11,0
		30 – 180	2,1 – 12,4

Seat Materials:

- Jorcote on SST – Standard
- Other materials available – Consult factory

Diaphragm Materials:

- Jorlon - Standard
- Stainless Steel - Standard
- Buna-N - Standard
- Viton – Optional

Service: Steam, water, oil, gas, air and chemicals

Shutoff: ANSI Class IV

Options:

- **Double Bolting:** increases the pressure rating of the valve and ensures a tight seal between the spring housing and the body for services with high inlet pressures
- **High Pressure Spring Housing:** The HP option is an elongated spring housing that features a large spring for high pressure setpoints (up to 450 psi/31bar)
- **Handwheel:** the H option is a handwheel that is mounted on the adjusting screw to allow for easy setpoint changes
- **Exotic Alloys:** where service conditions dictate the use of specialty materials, the Mark 60 Series can be produced with bodies, trim and seats in Monel, Alloy 20, Hastelloy B, Hastelloy C, Titanium and others
- **GP Option:** grain processing modification for starch cookers and other viscous services. Available on Stainless Steel valves in 1/4" – 2" sizes only (DN8 – DN50)
- **Cryogenic Service:** CR option is a special spring housing for use if valve is in cryogenic service

CV Values & Maximum Differential Pressures

Cv (Kv)	Size (DN)	Seat Material	Max. ΔP PSI (bar)
0.84 (0,74)	1/4" (DN8)	Jorcote	400 (27,6)
1.6 (1,4)	3/8" (DN12)	Jorcote	400 (27,6)
2.5 (2,2)	1/2" & 3/4" (DN15 & DN20)	Jorcote	400 (27,6)
4.4 (3,8)			
6.4 (5,5)	1" & 1-1/4" (DN25 & DN32)	Jorcote	400 (27,6)
9.5 (8,2)			
15 (12,9)	1-1/2" (DN40)	Jorcote	325 (22,4)
25 (21,5)	2" (DN50)	Jorcote	325 (22,4)
30 (25,8)			
55 (47,3)	2-1/2" (DN65)	Jorcote	150 (10,34)
115 (99)	3" (DN75)	Jorcote	150 (10,34)
200 (172)	4" (DN100)	Jorcote	150 (10,34)

Low Flow Cv's: reduced Cv's (Kv's) are available. Cv (Kv) ratings of smaller sized valves can be supplied in a larger valve size

0.42 (0,36)	0.21 (0,18)	0.08 (0,07)	0.04 (0,03)	0.02 (0,02)
0.008 (0,007)	0.004 (0,003)	0.002 (0,002)	0.0008 (0,007)*	

* N/A in 316SS

MARK 60 SELF-OPERATED PRESSURE REGULATORS

MAXIMUM WORKING PRESSURE, PSI

- Mark 60 Size Range: 1/4" – 2"

Temp °F	DI Body			BRZ Body		
	150#	300#	TE	150#	300#	TE
-20 to 100	250	300 [600]	300 [600]	225	300 [500]	300 [500]
200	235	300 [600]	300 [600]	215	300 [475]	300 [475]
300	215	300 [565]	300 [600]	195	300 [425]	300 [425]
400	200	300 [525]	300 [600]	170	300 [375]	300 [375]
500	170	300 [495]	300 [600]	150	300 [325]	300 [325]
600	140	300 [465]	300 [600]	—	—	—
650	125	300 [450]	300 [600]	—	—	—

- Mark 60 Size Range: 1/4" – 2"

Temp °F	CS Body			SS Body		
	150#	300#	TE	150#	300#	TE
-20 to 100	285	300 [740]	300 [950]	275	300 [720]	300 [950]
200	260	300 [675]	300 [950]	240	300 [620]	300 [950]
300	230	300 [655]	300 [950]	215	300 [560]	300 [950]
400	200	300 [635]	300 [950]	195	300 [515]	300 [950]
500	170	300 [600]	300 [950]	170	300 [480]	300 [950]
600	140	300 [550]	300 [950]	140	300 [450]	300 [900]
650	125	300 [535]	300 [950]	125	300 [445]	300 [890]

- Mark 60 Size Range: 2-1/2" – 4"

Temp °F	DI Body		CS Body		SS Body	
	150#	300#	150#	300#	150#	300#
-20 to 100	250	500	285	500	275	500
200	235	500	260	500	240	500
300	215	500	230	500	215	500
400	200	500	200	500	195	500
500	170	495	170	500	170	500

- Mark 60HP Size Range: 1/2" – 2"

Temp °F	CS Body	SS Body
	600# Flange or NPT	600# Flange or NPT
100	1480	1440
200	1355	1240
300	1315	1120
400	1270	1030
500	1208	955
600	1098	905
650	1075	890

MAXIMUM WORKING PRESSURE, BAR

- Mark 60 Size Range: DN8 – DN50

Temp °C	DI Body			BRZ Body		
	150#	300#	TE	150#	300#	TE
-29 to 38	17	21 [41]	21 [41]	16	21 [34]	21 [34]
93	16	21 [41]	21 [41]	15	21 [33]	21 [33]
149	15	21 [39]	21 [41]	13	21 [29]	21 [29]
204	14	21 [36]	21 [41]	12	21 [26]	21 [26]
260	12	21 [34]	21 [41]	10	21 [22]	21 [22]
316	10	21 [32]	21 [41]	—	—	—
343	9	21 [31]	21 [41]	—	—	—

- Mark 60 Size Range: DN8 – DN50

Temp °C	CS Body			SS Body		
	150#	300#	TE	150#	300#	TE
-29 to 38	20	21 [51]	21 [66]	19	21 [49]	21 [66]
93	18	21 [47]	21 [66]	17	21 [43]	21 [66]
149	16	21 [45]	21 [66]	15	21 [39]	21 [66]
204	14	21 [44]	21 [66]	13	21 [36]	21 [66]
260	12	21 [41]	21 [66]	12	21 [33]	21 [66]
316	10	21 [38]	21 [66]	10	21 [31]	21 [62]
343	9	21 [37]	21 [66]	9	21 [31]	21 [61]

- Mark 60 Size Range: DN65 – DN100

Temp °C	DI Body		CS Body		SS Body	
	150#	300#	150#	300#	150#	300#
-29 to 38	17	34	20	34	19	34
93	16	34	18	34	17	34
149	15	34	16	34	15	34
204	14	34	14	34	13	34
260	12	34	12	34	12	34

- Mark 60HP Size Range: DN15 – DN50

Temp °C	CS Body	SS Body
	600# Flange or NPT	600# Flange or NPT
38	102	99
93	93	85
149	91	77
204	88	71
260	83	66
316	75	62
343	74	61

Notes:

1. Double bolting option is required to reach pressures indicated in Brackets [].
2. If weld flanges are supplied, use ratings in "TE" column or flange rating, whichever is less (i.e. ANSI 600/900 flanges or PN64/100 flanges).
3. Consult factory for availability of ANSI/DIN/JIS flanges not indicated above.

DIMENSIONS – MARK 60/MARK 60QC

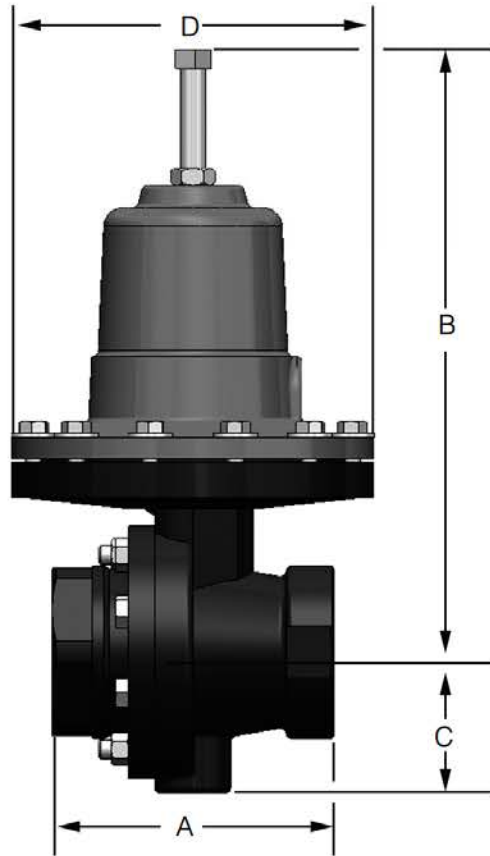

• Threaded & FSW Ends, Inches

Size	Material	A	B	C	D	Weight (lbs)
1/4" - 3/8"	DI/BRZ	4.12	8.50	1.69	5.12	10
	CS/SS	4.12	8.50	1.69	5.12	12
1/2"	DI/BRZ	3.62	8.50	1.69	5.12	10
	CS/SS	3.62	8.50	1.69	5.12	12
3/4"	DI/BRZ	3.62	8.50	1.69	5.12	10
	CS/SS	3.62	8.50	1.69	5.12	12
1"	DI/BRZ	4.12	10.00	2.62	7.09	21
	CS/SS	4.18	10.75	2.62	7.09	25
1-1/4"	DI/BRZ	4.12	10.00	2.62	7.09	21
1-1/2"	DI/BRZ	4.50	10.25	2.31	7.09	23
	CS/SS	4.81	11.00	2.25	7.09	31
2"	DI/BRZ	4.50	10.25	2.75	7.09	26
	CS/SS	5.50	11.00	2.75	7.09	35

• Threaded & FSW Ends, Metric

Size	Material	A	B	C	D	Weight (kgs)
DN8 - DN12	DI/BRZ	105	216	43	130	4,5
	CS/SS	105	216	43	130	5,4
DN15	DI/BRZ	92	216	43	130	4,4
	CS/SS	92	216	43	130	5,4
DN20	DI/BRZ	92	216	43	130	4,5
	CS/SS	92	216	43	130	5,4
DN25	DI/BRZ	105	254	67	180	9,5
	CS/SS	106	273	67	180	11,3
DN32	DI/BRZ	105	254	67	180	9,5
DN40	DI/BRZ	114	260	59	180	10,4
	CS/SS	122	279	57	180	14,0
DN50	DI/BRZ	114	260	70	180	11,8
	CS/SS	140	279	70	180	15,9

DIMENSIONS – MARK 60

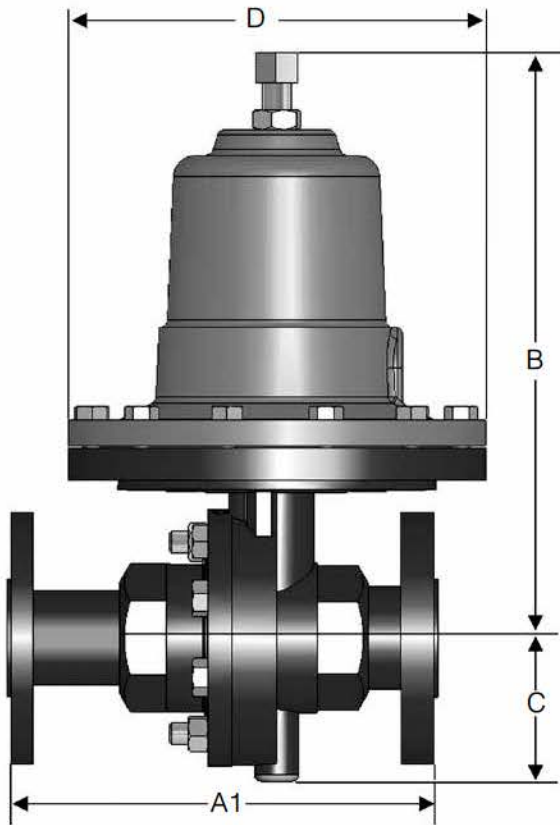

- Flanged Ends, ANSI, Inches

Size	ANSI Flange	A1		B		C	D	Weight (lbs)	
		DI/BRZ	CS/SS	DI/BRZ	CS/SS	ALL	ALL	DI/BRZ	CS/SS
1/2"	150#	7.25	7.25	9.00	9.00	1.69	5.12	13	15
	300#	7.50	7.50	9.00	9.00	1.69	5.12	14	16
3/4"	150#	7.25	7.25	9.00	9.00	1.69	5.12	14	16
	300#	7.62	7.62	9.00	9.00	1.69	5.12	16	17
1"	150#	7.25	7.25	11.25	11.75	2.62	7.09	26	34
	300#	8.75 ¹	7.75 ²	11.25	11.75	2.62	7.09	28	37
1-1/4"	150#	7.87	—	11.25	—	2.62	7.09	28	—
	300#	8.37	—	11.25	—	2.62	7.09	31	—
1-1/2"	150#	8.75	8.75	11.25	13.00	2.31	7.09	42	46
	300#	10.25 ¹	9.25 ²	11.25	13.00	2.31	7.09	45	52
2"	150#	10.00	10.00	11.50	13.25	2.75	7.09	46	50
	300#	10.50	10.50	11.50	13.25	2.75	7.09	49	55
Flanged End CS/SS									
Larger Sizes		A1		B		C	D	Weight (lbs)	
2-1/2"	125-150#	10.88		18.75		6.95	12.75	165	
	250-300#	11.50		18.75		6.95	12.75	165	
3"	125-150#	11.75		18.75		6.95	12.75	185	
	250-300#	12.50		18.75		6.95	12.75	185	
4"	125-150#	13.88		18.75		8.00	12.75	215	
	250-300#	14.50		18.75		8.00	12.75	215	

- Flanged Ends, Metric

① Not IFE and NOT per DIN3202

Size DN	ANSI Flange	A1		B		C	D	Weight (kgs)	
		DI/BRZ①	CS/SS	DI/BRZ	CS/SS	ALL	ALL	DI/BRZ	CS/SS
15	10/16	184	130	229	229	43	130	5,9	6,8
	25/40	184	130	229	229	43	130	6,4	7,3
20	10/16	184	150	229	229	43	130	6,4	7,3
	25/40	184	150	229	229	43	130	7,3	7,7
25	10/16	222	160	286	298	67	180	11,8	15,4
	25/40	222	160	286	298	67	180	12,7	16,8
32	10/16	222	—	286	—	67	180	12,7	—
	25/40	222	—	286	—	67	180	14,1	—
40	10/16	222	200	286	330	59	180	19,1	20,9
	25/40	222	200	286	330	59	180	20,4	23,6
50	10/16	254	230	292	337	70	180	20,9	22,7
	25/40	254	230	292	337	70	180	22,2	24,9
Flanged End CS/SS									
Larger Sizes		A1		B		C	D	Weight (kgs)	
65	10/16	276		476		177	324	75	
	25/40	292		476		177	324	75	
80	10/16	298		476		177	324	84	
	25/40	318		476		177	324	84	
100	10/16	353		476		203	324	98	
	25/40	368		476		203	324	98	

DIMENSIONS – MARK 60HP

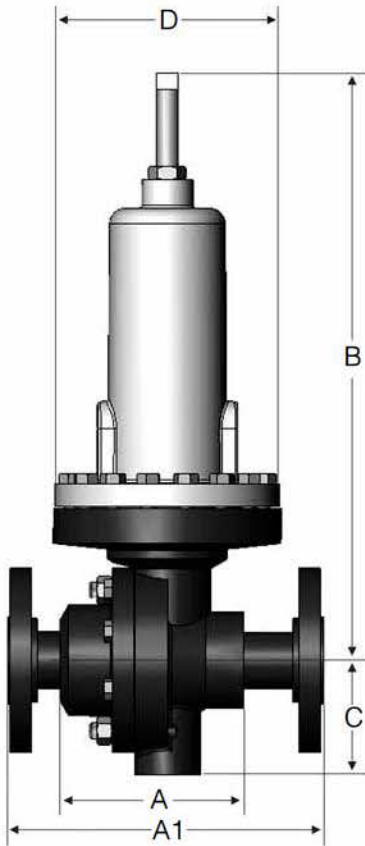

• Flanged Ends, Inches

Size	ANSI Flange	A1		B	C	D	Weight (lbs)
		DI/BRZ	CS/SS	ALL	ALL	ALL	
1/2"	150#	7.25	7.25	12.75	1.69	5.20	21 •
	300#	7.50	7.50	12.75	1.69	5.20	
	• 600#	8.00	8.00	12.25	1.69	5.20	
3/4"	150#	7.25	7.25	12.75	1.69	5.20	22 •
	300#	7.62	7.62	12.75	1.69	5.20	
	• 600#	8.12	8.12	12.25	1.69	5.20	
1"	150#	7.25	7.25	13.25	2.62	5.20	37
	300#	7.75	7.75	13.25	2.62	5.20	
	• 600#	8.25	8.25	12.75	2.62	5.20	
1-1/4"	150#	7.87	—	12.75	2.62	5.20	37
	300#	8.37	—	12.75	2.62	5.20	
1-1/2"	150#	8.75	8.75	13.75	2.31	5.20	45
	300#	9.25	9.25	13.75	2.31	5.20	
	• 600#	9.87	9.87	13.25	2.31	5.20	
2"	150#	10.00	10.00	14.00	2.75	5.20	49
	300#	10.50	10.50	14.00	2.75	5.20	
	• 600#	11.25	11.25	13.50	2.75	5.20	

- 600# are not IFE
- For IFE, add 1" to all "B" dimensions (1" – 2" sizes only)

• Threaded & FSW Ends, Inches

Size	Material	A	B	C	D	Weight (lbs)
1/2" - 3/4"	DI/BRZ	3.62	12.75	1.75	5.12	15
	CS/SS	3.62	12.75	1.75	5.12	17
1"	DI/BRZ	4.12	13.00	2.12	5.20	21
	CS/SS	4.18	13.25	2.12	5.20	25
1-1/4"	DI/BRZ	4.12	13.00	2.12	5.20	21
1-1/2"	DI/BRZ	4.50	13.25	2.31	5.20	23
	CS/SS	4.81	13.75	2.50	5.20	31
2"	DI/BRZ	4.50	13.25	2.50	5.20	26
	CS/SS	5.50	14.00	2.50	5.20	35

• Threaded & FSW Ends, Metric

Size	Material	A	B	C	D	Weight (lbs)
DN15 & 20	DI/BRZ	92	324	45	130	6,8
	CS/SS	92	324	45	130	7,7
DN25	DI/BRZ	105	330	54	132	9,5
	CS/SS	106	337	54	132	11,3
DN32	DI/BRZ	105	330	54	132	9,5
DN40	DI/BRZ	114	337	59	132	10,4
	CS/SS	122	349	64	132	14,1
DN50	DI/BRZ	114	337	64	132	11,8
	CS/SS	140	356	64	132	15,9

• Flanged Ends, Metric³

Size	ANSI Flange	A1		B ²	C	D	Weight (kgs)
		DI/BRZ ¹	CS/SS	ALL	ALL	ALL	
15	10/16	184	130	324	43	132	9,5
	25/40	184	130	324	43	132	
20	10/16	184	150	324	43	132	10
	25/40	184	150	324	43	132	
25	10/16	184	160	337	67	132	17
	25/40	184	160	337	67	132	
32	10/16	200	—	324	67	132	17
	25/40	200	—	324	67	132	
40	10/16	222	200	349	59	132	20
	25/40	222	200	349	59	132	
50	10/16	254	230	356	70	132	22
	25/40	254	230	356	70	132	

- ¹ Not IFE and not per DIN3202
- ² For IFE, add 25,4 mm
- For all DIN flanges, please consult factory

DIMENSIONS – MARK 61

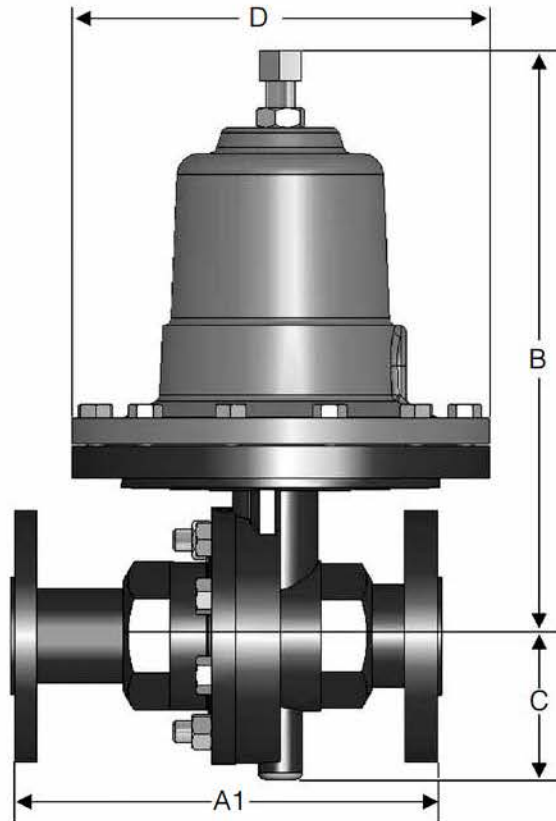

• Threaded & FSW Ends, Inches

Size	Material	A	B	C	D	Weight (lbs)
1/4" - 3/8"	DI/BRZ	4.12	10.25	2.25	7.12	12
	CS/SS	4.12	10.25	2.25	7.12	13
1/2" - 3/4"	DI/BRZ	3.62	10.25	2.25	7.12	12
	CS/SS	3.62	10.25	2.25	7.12	13

• Flanged Ends, ANSI, Inches

Size	ANSI Flange	A1		B		C	D	Weight (lbs)	
		DI/BRZ	CS/SS	DI/BRZ	CS/SS	ALL	ALL	DI/BRZ	CS/SS
1/2" & 3/4"	150#	9.62	9.62	10.25	10.25	2.25	7.12	26	26
	300#	10.25	10.25	10.25	10.25	2.25	7.12	29	29

• Threaded & FSW Ends, Metric

Size	Material	A	B	C	D	Weight (kgs)
DN8 - 10	DI/BRZ	105	260	57	181	5,4
	CS/SS	105	260	57	181	5,9
DN15 - 20	DI/BRZ	92	260	57	181	5,4
	CS/SS	92	260	57	181	5,9

• Flanged Ends, ANSI, Metric

Size	ANSI Flange	A1 ¹		B		C	D	Weight (kgs)	
		DI/BRZ	CS/SS	DI/BRZ	CS/SS	ALL	ALL	DI/BRZ	CS/SS
DN15 & 20	10/16	244	244	260	260	57	181	12	12
	25/40	260	260	260	260	57	181	13	13

¹ Not per DIN 3202

JORLON DIAPHRAGM - REVOLUTIONARY DIAPHRAGM SETS NEW STANDARD

- Easily retrofitted – Jorlon can be easily retrofitted in the field with no additional parts. For regulators purchased after the fall of 1991, only the diaphragm needs to be changed to retrofit either SST or elastomer diaphragms.
- Chemical compatibility – Jorlon is PTFE based, so it is compatible with most media except fluorinated gases and halogenated fluorocarbons. Whether the application is steam, process gases or fluids, Jorlon should be your choice.
- High pressure limits – The Mark 60HP has been pressure tested well in excess of the maximum allowable pressures of the valve. For the smaller MK60 2" (DN50) and below, it is fully rated to ANSI 300 Class pressure of 720 psi (50 bar) @ 100°F (38°C). The outstanding performance is a combination of Jorlon and sliding gate seat technology.
- Improved droop performance – A metal diaphragm is much more rigid than an elastomer diaphragm. As such, metal diaphragms have decreased sensitivity thereby diminishing performance and accuracy in a self-operated regulator. Jorlon will improve droop performance when used instead of a SST diaphragm as its properties are more similar to those of elastomer materials.
- Less expensive – Jorlon is less expensive than many other diaphragm materials, further increasing its customer value.
- High steam pressure capability – Extensive steam testing of Jorlon in the Mark 60 pressure regulator has shown this material is ideal for high pressure steam service. For Mark 60 2" (DN50) and below, Jorlon may be used in saturated steam service up to 405 psi (28 bar) @ 450°F (232°C). For steam service in larger Mark 60s, up to 125 psi (8,6 bar) saturated steam.
- Fast delivery – Rely on our 36 hour delivery with Jorlon as the diaphragm material.
- Extremely long life – Under 300 psi air, Jorlon surpasses 1,000,000 full stroke cycles without failure. The harshest test was on 450°F saturated steam, where Jorlon exceeded the cycle count for stainless steel by over 150 times - the test was stopped and the Jorlon diaphragm had yet to fail.
- Lower cost of ownership – Less droop provides more accuracy, improving efficiency and productivity. Extremely long life results in more production up-time, fewer spare parts expenses and less repair labor.

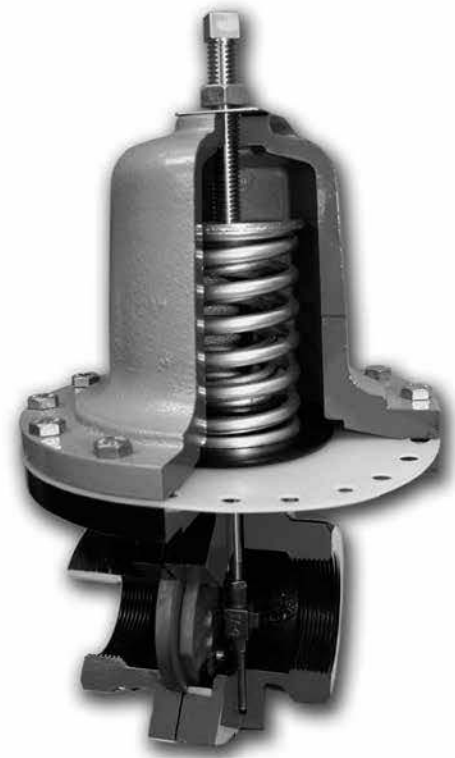

ORDERING SCHEMATIC

Model No	Size	Body Mat'l	1	2	3	4	5	6	7	8	9	10	11	12

	Model
60	Standard
60HP	High Pressure
60QC	Quick Change
61	Large Diaphragm

	Seat Material
A	303SST (1/4" - 2")
B	316SST (1/4" - 2")
V	303SS/Jorcote
W	316SS/Jorcote

	Size
025	1/4" (DN8)
038	3/8" (DN10)
050	1/2" (DN15)
075	3/4" (DN20)
100	1" (DN25)
125	1-1/4" (DN32)
150	1-1/2" (DN40)
200	2" (DN50)
250	2-1/2" (DN65) (MK60/60HP only)
300	3" (DN80) (MK60/60HP only)
400	4" (DN100) (MK60/60HP only)

	Cv (Kv)		
1	0.21 (0,28)	9	15 (12,9)
2	0.42 (0,36)	A	25 (21,6)
3	0.84 (0,72)	B	30 (25,9)
4	1.6 (1,4)	D*	55 (47,4)
5	2.5 (2,2)	F*	85 (73,3)
6	4.4 (3,8)	G*	115 (99,1)
7	6.4 (5,5)	I*	200 (172)
8	9.5 (8,2)	* 2-1/2" - 4" only	

MK61 available in 1/4" through 3/4" only

	Body Material
DI	Ductile Iron
BR	Bronze (1/4" - 2")
CS	Carbon Steel
S6	Stainless Steel
CI	Cast Iron (2-1/2" - 4')

7&8	MK 60 Spring Range PSI (Bar)		
	1/4" - 3/4"	1" - 2"	2-1/2" - 4"
15	2-20 (0,14-1,4)	05	1-5 (0,07-0,34)
16	2-23 (0,14-1,6)	20	3-8 (0,2-0,6)
37	10-38 (0,7-3)	28	5-20 (0,34-1)
56	20-55 (1-4)	34	10-30 (0,7-2)
81	35-160 (2-11)	53	20-45 (1-3)
A6	95-220 (7-15)	75	30-95 (2,7)
D8	30-85 (2-6)	97	60-160 (4-11)

1 & 2	End Connections
	1/4" - 2" MK60/61
PT	NPT
BT	BSPT
BP	BSPP
SW	FSW
I5	150# IFE
F5	150# FE (Except IFE)
I3	300# IFE
F3	300# FE (Except IFE)
	2-1/2" - 4" MK60
I1	125# IFE
I5	150# IFE
I2	250# IFE
I3	300# IFE
I7	PN10 DIN IFE (CS/S6) DN15-150
I6	PN16 DIN IFE (CS/S6) DN15-150
I8	PN25 DIN IFE (CS/S6) DN15-150
I4	PN 40 DIN IFE (CS/S6) DN15-150

7 & 8	MK60HP Spring Range PSI (Bar)	
	1/2" - 2"	2-1/2" - 4"
A1	75-190 (5-13)	71
A7	100-320 (7-22)	98
A9	150-450 (10-31)	

7 & 8	MK61 Spring Range PSI (Bar)		
05	1-5 (0,07-0,34)	56	20-55 (1-4)
10	2-12 (0,14-0,8)	63	20-80 (1-6)
17	2-25 (0,14-2)	87	40-115 (3-8)
36	10-35 (0,7-2)	70	25-160 (2-11)
		80	30-180 (2-12)

3 & 4	Trim
S3	303SS
S6	316SS
I3	303SSF/IFE (1/2" - 2")
I6	316SSF/IFE (1/2" - 2")

9 & 10	Diaphragm
S6	316SST (1/4" - 2" only)
VI	Viton
BN	Buna-N (standard above 2")
JL	Jorlon

11 & 12	Actuator
MD	DI for Metal Diaphragm (1/4" - 2" only)
ED	DI for Elastomer Diaphragm
SM	316 for Metal Diaphragm

Mark 601/602 Series

High Flow Pressure Regulators

The Mark 601 and 602 meet higher capacity requirements than standard regulators. The High Flow Mark 601 has Cv's as high as 50 (43 Kv) and the Super High Flow Mark 602 has Cv's up to 70 (60,2 Kv). Each valve is standard with Jordan's Sliding Gate Seats, which helps to reduce the droop commonly associated with high flow regulators.

Jordan's unique self-operated sliding gate pressure regulator offers:

- Shorter stroke than a globe or plug-style valve
 - Faster response
 - Less offset
 - Smaller and lighter weight than globe-style valves
 - Longer diaphragm life
- Straight-through flow
 - Less turbulence, erosion and noise
 - Improved rangeability
 - Longer seat life
- Ease of maintenance
 - Interchangeable seats and Cv's
 - Fewer spare parts
 - Self-cleaning seats
 - No gaskets or o-rings

SPECIFICATIONS

Sizes: 1-1/2" & 2" (DN40 & DN50)

End Connections:

- Threaded – NPT, BSPT, BSPP
- ANSI Flanges (150#, 300#)
- DIN Flanges (PN 10/16, PN 25/40)

Body Materials

- Ductile Iron
- Bronze
- Carbon Steel (A216 WCB)
- Stainless Steel (A351/CF8M)

Trim Materials

- 303SST – Standard on Ductile Iron, Bronze, Carbon Steel valves
- 316SST – Standard on Stainless Steel valves
- Monel, Hastelloy and other Alloys available



Seat Materials

- Jorcote on SST – Standard

Diaphragm Materials

- Stainless Steel – standard
- Jorlon – standard
- Buna-N – optional
- Viton – optional

Service: Steam, water, oil, gas, air and chemicals

Shutoff: ANSI Class IV

Reduced Pressure Control Ranges: Select a range to match your setpoint. For optimal performance, your setpoint should fall in the upper portion of the selected range.

Model	Size (DN)	Spring Ranges	
		PSI	Bar
601 & 602	1-1/2" – 2" (DN40 – DN50)	20 – 45	1,4 – 3,1
		30 – 95	2,1 – 6,6
		60 – 160	4,1 – 11,0

Cv Values & Maximum Differential Pressures

- Mark 601

Cv (Kv)	Size (DN)	Seat Material	Maximum ΔP PSI (BAR)
25 (21,5)	1-1/2" & 2" (DN40 & DN50)	Jorcote	150 (10,3)
30 (25,8)	1-1/2" & 2" (DN40 & DN50)	Jorcote	150 (10,3)
3 5 (30,1)	1-1/2" & 2" (DN40 & DN50)	Jorcote	150 (10,3)
45 (38,7)	1-1/2" (DN40)	Jorcote	150 (10,3)
50 (43,0)	2" (DN50)	Jorcote	150 (10,3)

- Mark 602

Cv (Kv)	Size (DN)	Seat Material	Maximum ΔP PSI (BAR)
65 (56)	1-1/2" (DN40)	Jorcote	150 (10,3)
70 (60)	2" (DN50)	Jorcote	150 (10,3)

DIMENSIONS – MARK 601/602

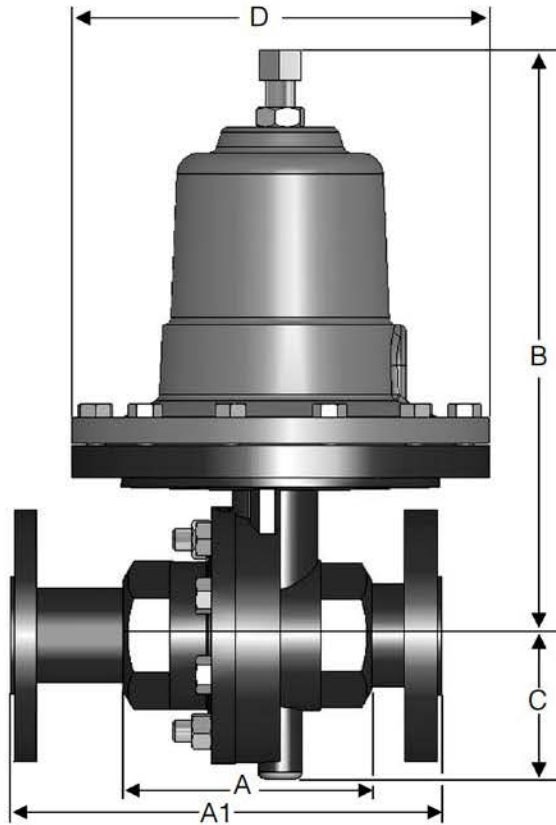

• Threaded & FSW Ends, Inches

Size	Material	A	B	C	D	Weight (lbs)
1-1/2" & 2"	DI/BRZ	4.50	11.50	2.75	7.09	26
	CS/SS	5.50	11.75	2.75	7.09	35

• Threaded & FSW Ends, Metric

Size	Material	A	B	C	D	Weight (kgs)
DN40 - 50	DI/BRZ	114	292	70	180	11,7
	CS/SS	140	298	70	180	15,9

• Flanged Ends, Inches

Size	ANSI Flange	A1		B		C	D	Weight (lbs)	
		DI/BRZ	CS/SS	DI/BRZ	CS/SS			ALL	ALL
1-1/2" ¹	150#	10.00	10.00	11.50	11.75	2.31	7.09	42	46
	300#	10.25	10.25	11.50	11.75	2.31	7.09	45	52
2"	150#	10.00	10.00	11.50	13.25 ²	2.75	7.09	46	50
	300#	10.50	10.50	11.50	13.25 ²	2.75	7.09	49	55

¹ Not ANSI Standard

² IFE only

• Flanged Ends, Metric

Size	ANSI Flange	A1		B		C	D	Weight (kgs)	
		DI/BRZ ²	CS/SS	DI/BRZ	CS/SS			ALL	ALL
DN40 ¹	10/16	254	254	292	298	70	180	19,1	20,9
	25/40	260	260	292	298	70	180	20,4	23,6
DN50	10/16	254	230 ²	292	336 ²	70	180	20,9	22,7
	25/40	268	230 ²	292	336 ²	70	180	22,2	24,9

¹ Not per DIN3202

² IFE only

ORDERING SCHEMATIC

Model No	Size	Body Mat'l	1	2	3	4	5	6	7	8	9	10	11	12	13	14	15

Model	
601	High Flow
602	Super High Flow

5	Seat Material
V	303SS/Jorcote
W	316SS/Jorcote

Size	
150	1-1/2" (DN40)
200	2" (DN50)

6	Cv (Kv)
A	25 (22)
B	30 (26)
V	35 (30)
W	45 (39)
C	50 (43)
Y	65 (56)
E	70 (60)

Body Material	
DI	Ductile Iron
BR	Bronze
CS	Carbon Steel
S6	Stainless Steel

7 & 8	Spring Range PSI (Bar)
53	20 - 45 (1,4 - 3,0)
75	30 - 95 (2,1 - 6,6)
97	60 - 160 (4,1 - 11,0)

1 & 2	End Connections
PT	NPT
BT	BSPT
I5	150# IFE, CS or SST*
F5	150# FE, DI or BR
I7	PN10 IFE, CS or SST*
F7	PN10 FE, DI or BR
I6	PN16 IFE, CS or SST*
F6	PN16 FE, DI or BR
BP	BSPP
SW	FSW
I3	300# IFE, CS or SST*
F3	300# FE, DI or BR
I8	PN25 IFE, CS or SST*
F8	PN25 FE, DI or BR
I4	PN40 IFE, CS or SST*
F4	PN40 FE, DI or BR

9 & 10	Diaphragm
S6	316SST
VI	Viton
BN	Buna-N
JE	Jorlon

11 & 12	Actuator
MD	DI for Metal Diaphragm
ED	DI for Elastomer Diaphragm
SM	316 for Metal Diaphragm

3 & 4	Trim
S3	303SS
S6	316SS
I3	303SSF/IFE (1/2" - 2" CS/S6)
I6	316SSF/IFE (1/2" - 2" CS/S6)

13 & 14	Double Bolting
00	None
ZZ	Non-Standard

15	Accessories
0	None
6	316SS Bolting
7	Hi-temperature Bolting
Z	Non-Standard

MARK 60 SELF-OPERATED PRESSURE REGULATORS

Jordan Valve offers a full range of pressure regulators in addition to the Mark 60 Self-Operated Pressure Regulator

Mark 62 Internally Piloted Pressure Regulator

The Mark 62 is a specialty valve designed for critical application regulation in locations where space is limited. Small and lightweight in design, the Mark 62 valve provides the accuracy of a piloted valve with the size, weight, and appearance of a single, self-operated valve.



Mark 63/64 Differential Pressure Regulators

The Mark 63 is designed to maintain a constant differential between the pressure on the discharge side of the regulator and the signal pressure loaded on the diaphragm. The Mark 64 provides the same flow capacity as the Mark 63 but with less offset in controlled pressure due to a larger diaphragm.



Mark 65 Vacuum Regulators

The Mark 65 vacuum regulators control very accurately and shutoff tightly to maintain the proper vacuum setting. They are used to maintain vacuums at predetermined settings and to regulate vacuums on evaporators, cookers, grinding fixtures, milking machines, altitude chambers and other vacuum systems.



Mark 66 Air-Loaded Pressure Regulators

The Mark 66 is a highly accurate and economical air loaded pressure regulator that provides regulation from a local station or from a remote station. The operation of the MK66 requires no control spring or pilot. Instead, a static signal is applied to the top of the diaphragm to determine the setpoint.



Mark 67 Pilot-Operated Pressure Regulators

The Mark 67 is for critical pressure reducing applications and provides a greater accuracy and lower offset than can be achieved with a self-operated regulator. Because of its versatility in control, and its accuracy, the Mark 67 can be used in a wide variety of applications including: controlling the pressure of gaseous oxygen to furnaces at steel mills, controlling pressure of sealing oil on turbines, and pressure control on steam mains and distribution lines.



Mark 68G Pressure Regulator

The Mark 68G is a globe-style pressure reducing regulating valve that offers high capacity, accurate regulation, and easy servicing, making it the ideal choice for your industrial-grade pressure reducing applications.



Mark 68HP High Pressure Regulating Valve

The Mark 68HP is designed primarily for high pressure steam service as commonly found in power plants, refineries, pulp & paper mills, and other high pressure process applications.



Jordan Valve a division of Richards Industries
 3170 Wasson Road • Cincinnati, OH 45209
 513.533.5600 • 800.543.7311 • 513.871.0105 (f)
 jordan@richardsind.com • www.jordanvalve.com