



JORDAN VALVE

3170 Wasson Road • Cincinnati, OH 45209 USA
Phone 513-533-5600 • Fax 513-871-0105
info@richardsind.com • www.jordanvalve.com

I & M Mark 75HW (1" – 2")

Installation & Maintenance Instructions for Mark 75HW Wafer Hand Valve

Warning: Jordan Valve Control Valves must only be used, installed and repaired in accordance with these Installation & Maintenance Instructions. Observe all applicable public and company codes and regulations. In the event of leakage or other malfunction, call a qualified service person; continued operation may cause system failure or a general hazard. Before servicing any valve, disconnect, shut off, or bypass all pressurized fluid. Before disassembling a valve, be sure to release all spring tension.

Please read these instructions carefully!

Your Jordan Valve product will provide you with long, trouble-free service if it is correctly installed and maintained. Spending a few minutes now reading these instructions can save hours of trouble and downtime later. When making repairs, use only genuine Jordan Valve parts, available for immediate shipment from the factory.

Ideal Installation

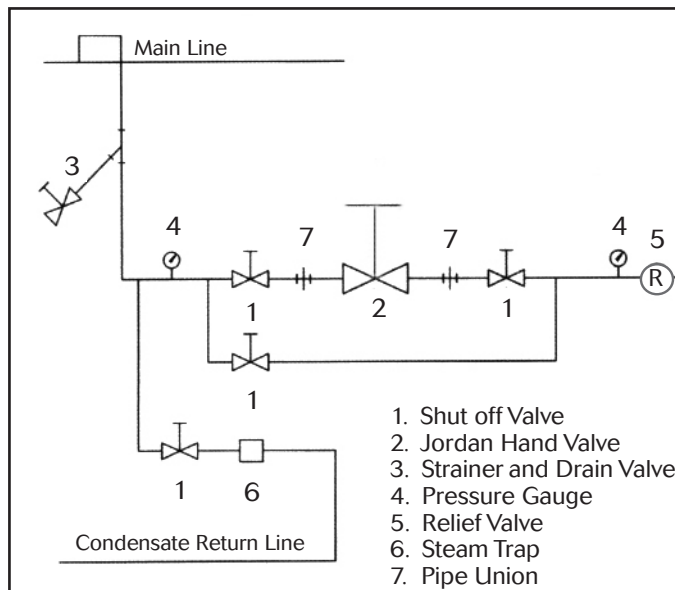

- To protect the valve from grit, scale, thread chips and other foreign matter, ALL pipelines and piping components should be blown out and thoroughly cleaned before the installation process begins.
- Shutoff valves, pressure gauges and by-pass piping should be installed as indicated in the diagram above to provide easier adjustment, operation, and testing.
- A line strainer should be installed on the inlet side of the valve to protect it from grit, scale and other foreign matter. A 0.033 perforated screen is usually suitable for this purpose. Line strainers are available from Jordan Valve.
- For best control, 3' 0" straight sections of pipe

- should be installed on either side of the valve.
- The disc in the valve body must be positioned in the upstream portion of the flow, and the set-screws should be on the downstream side of the valve. Ideally for steam applications, the valve should be installed in the highest horizontal line of piping to provide drainage for inlet and outlet piping, to prevent water hammer, and to obtain faster response.
- If possible, install a relief valve downstream from the valve. Set at 15 psi above the control point of the valve.
- In hot vapor lines, upstream and downstream piping near the valve should be insulated to minimize condensation.
- In gas service, expand the outlet piping at least one pipe size, if the control pressure (downstream) is 25 percent of the inlet pressure or less. A standard tapered expander connected to the outlet of the valve is recommended.
- Where surges are severe, a piping accumulator is recommended.
- On steam control applications, install a steam trap with sufficient capacity to drain the coil or condenser. Be sure to have a good fall to the trap, and no backpressure. Best control is maintained if the coil or condenser is kept dry.
- Tighten pipe flange bolts just enough to effect a good seal.

Start-Up Procedure

- For direct acting valves, turn the handle clockwise to close. For reverse acting valves, turn the handle clockwise to open.
- The hand valve has been pre-set by Jordan Valve, however, finer adjustment may be required to compensate for the system conditions of your application.
- With inlet, outlet and bypass shutoff valves closed, and no pressure in the downstream line, gradually open the inlet valve enough to start flow through the valve. Increase the flow gradually by slowly opening the inlet shutoff valve. Do not fully open

PROTECT VALVES WITH LINE STRAINERS

the inlet valve until you are sure that the controller and valve have control of the system. Usually, the handwheel on the inlet valve will turn freely when this point is reached.

4. To shut off the line fluid, close the inlet shutoff valve first, and then close the outlet shutoff valve.
5. Loosen the body set screws (42).
6. It may be necessary to re-torque the pipe flange bolts.

Maintenance

Caution: Make certain that there is no pressure in the valve before loosening any fittings or joints. The following steps are recommended:

1. Close the inlet shutoff valve.
2. Allow pressure to bleed off through the downstream piping. Do not attempt to reverse the flow through the valve by bleeding pressure from the upstream side of the valve.
3. When the pressure gauges indicate that all pressure has been removed from the system, close the outlet shutoff valve and the valve may be serviced.

Note: refer to the drawing at the end of this document for description and proper orientation of parts.

Valve Seats

A. Disassembly

The sliding Gate Seats of Jordan Valves are lapped to light band flatness. Maintaining such tolerances is of paramount importance for your assurance of excellent control and tight shutoff. DO NOT use metallic objects in removing the seats. Care in handling is imperative.

1. Tighten the body set screws (17). Follow instructions under the Maintenance section to remove valve from line.
2. Disassemble the valve only as far as necessary to do the required work.
3. When replacing seats it is recommended by Jordan Valve that the packing be replaced if the valve is older than one year. Follow the instructions under Packing Replacement.
4. Remove the Set screws (17), and remove the Plate (2), Disc (8), and Gasket (13). Place the plate on the bench with the lapped surface up.
5. Clean all parts of the Body (1) with a good quality solvent. Remove Guide screws (12) and Guides (11), the Disc (8) and Plate (2) can then be cleaned. Place a piece of 4/0 polishing cloth or jeweler's cloth on a smooth flat surface such as a surface plate and polish the Disc, and Plate lapped surfaces using a figure "8" motion. If the parts are

scarred, do not attempt to re-lap them, but return them to the factory for repair or replacement.

B. Reassembly

1. Place the plate (2) on a clean, flat work surface with the lapped side up. The small single locator hole should be towards you.
2. If the valve action is "reverse", place the Disc (8) on the Plate with the words "TOP REVERSE" away from you. If the valve action is "direct", the words "TOP DIRECT" should be away from you. Move the Disc (8) until the slots are in perfect alignment with those of the plate (2).
3. Place the Guides (11) on either side of the Disc (8), and secure them with the Guide screws (12) so that the Disc (8) can move freely up and down but not side to side.
4. Lightly lubricate both side of the Body Gasket (13) with an anti-seize compound. Place a new Body Gasket (13) into the Body (1).
5. Hold the Plate / Disc assembly together and insert it into the large end of the Body (1) with the slots perpendicular to the stem (3), taking care that the "T" slot in the Disc (8) engages the head of the valve stem. The word "TOP" should be towards the actuator.
6. Replace the Set screws (17) in the Body (1).
7. Follow instructions under Installation & Start Up Procedure when placing valve back in service.

Stem & Packing Replacement

1. Remove the Plate (2) and Disc (8), following the procedure outlined under the Valve Seats section.
2. Loosen the Stem Connector Nut (4) and Bolt and remove Connector Halves.
3. Back out the Yoke SST Screws (9) and allow the Body (1) to separate from the Yoke (18).
4. Remove the Packing Flange Nuts (19) and the Packing Flange (7).
5. Before pulling the Stem (3) completely out of the Body, you must remove the Stem T-Head (10) by unscrewing it from the Stem (3). Remove the Packing Assembly (14, 15, & 16). The remaining parts of the Packing Assembly can "fished" out with a small screwdriver. (Be careful not to damage the packing bore.)
6. Clean the packing bore in the Body with solvent and blow dry.
7. Clean the Stem (3) with solvent if it is to be reused.
8. Replace the Packing Spring (14) and Packing Retainer (15) in the packing bore.
9. Reassemble the new Packing (16) on the stem (3) with the open part of the "V" downward (^). There will be a flat on the top and bottom. Place the Packing Follower (6) on top of the Packing (16). (Coat each piece of the packing set with a suitable lubricant.)

10. Gently push the Packing (16) into the packing bore and place the Packing Flange (7) on the stem.
11. Put the Packing Flange Nuts (19) on the Packing Studs (20) and partially tighten. At this point it is recommended that you gently move the stem up and down three or four times to align the assembly.
12. Tighten the Packing Flange nuts (19) until the Packing Follower (6) bottoms out on the top of the body.
13. Reassemble Yoke (18) to the valve Body (1) with the four Yoke Screws (9). Reassemble the Seats by inserting in the body as outlined in Valve Assembly Section.

Valve Stroke Adjustment

Use the travel locks (24) to adjust top and bottom of stroke.

Changing Valve Action

The action of a Sliding-Gate Valve may be changed from DIRECT ACTING to REVERSE ACTING, or vice versa, by rotating the Disc (8) but not the Plate (2) 180°. Check the valve stroke and orifice alignment and adjust, if required, as outlined in the Valve Stroke Adjustment section.

Ordering Spare Parts

Use only genuine Jordan Valve parts to keep your valve in good working order. So that we can supply the parts, which were designed for your valve, we must know exactly which product you are using. The only guarantee to getting the correct replacement parts is to provide your Jordan Representative with the valve serial number. This number is located on the valve identification tag. If the serial number is not available, the parts needed for your valve might be determined using the following information: Model Number, Valve Body Size, Seat Material and Cv Rating, Spring Range and Set Point, Trim Material, Part Name - Number and Quantity.

NOTE: Any parts ordered without a valve serial number that are found to be incorrect are subject to up to a minimum 25% restock charge when returned.

Mark 75HW Illustration and Parts List (1" - 2")

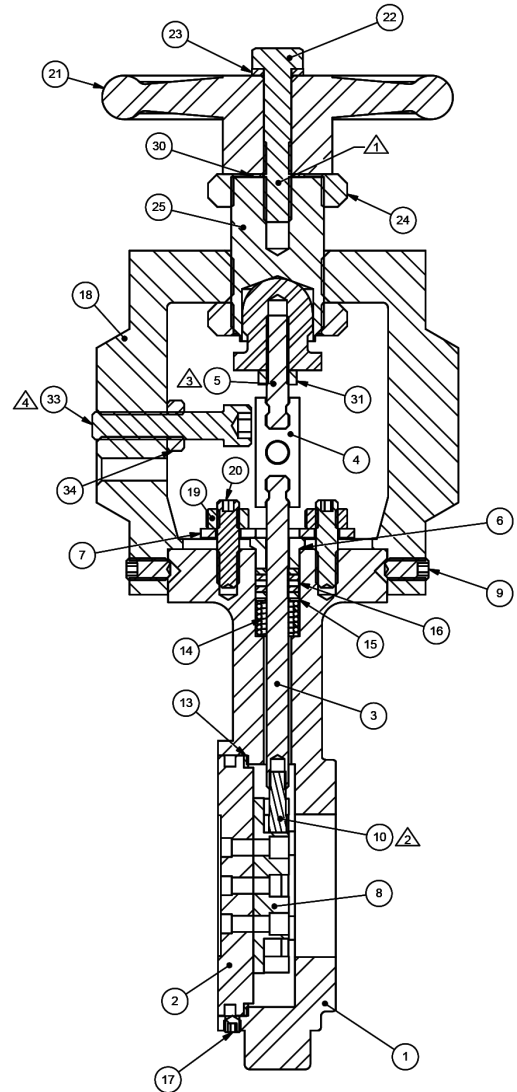

Notes:

- △ Wicking Loc- Tite (290) on these threads
- △ Begin with Full Insertion
- △ Recommended Insertion 0.625/0.260 min.
- △ Engage Bolt as Close as Possible without Touching Stem Connector

Item	Description	Qty.	Item	Description	Qty.
1	Body	1	19	Nut, Hex 1/4-20	2
2	Plate, MK75 Cv 72	1	20	SHSS 1/4-20 x 1"	2
3	Stem F/T-Head	1	21	Handwheel	1
4	Stem Connector	2	22	HHCS, 5/16-18 x 1 3/4"	1
5	Stem Adapter	1	23	Lockwasher, 5/16"	1
6	Packing Follower	1	24	Nut, Hex 1 1/16-16	2
7	Packing Flange	1	25	Stem/Tip Ass'y (NRT)	1
8	Disc	1	26	Stem Connector Stud *(NS)	1
9	SHSS Cone PT, 1/4-20 x 5/8"	4	27	Lockwasher, 1/4" *(NS)	1
10	T-Head	1	28	Travel Scale Ass'y *(NS)	1
11	Disc Guide *(NS)	2	29	Sheet Screw, 6-32 x 3/8" *(NS)	2
12	FMS, 8-32 x 5/8" *(NS)	4	30	Internal Tooth LW Type A-5/16"	1
13	Body Gasket	1	31	Jam Nut	3* (2 NS)
14	Packing Spring	1	32	SHSS, Cup PT, 10-24 x 3/8" *(NS)	2
15	Washer	1	33	SHCS, 5/16-18 x 1.5	1
16	Packing	1	34	Jam Nut, 5/16-18	1
18	Yoke	1	35	Stem	1