

Esprit® HD Series IP Positioning System

ES5230 SERIES STANDARD AND PRESSURIZED MODELS

Product Features

- Up to 1920 x 1080 Resolution
- 16:9 Aspect Ratio; 1080p at 30 Images per Second (ips)
- 2.0 Megapixel (MPx), 30X Optical Zoom, 12X Digital Zoom, Wide Dynamic Range (WDR) Camera
- Ability to Control and Monitor Video Over IPv4 and IPv6 Networks
- Built-in Analytics Including AutoTracker and Adaptive Motion Detection
- 2 Simultaneous Video Streams: Dual H.264 or H.264 and Scalable MJPEG
- 360° Continuous Pan Rotation at 100° per Second
- Supported Protocols: TCP/IP, UDP/IP (Unicast, Multicast IGMP), UPnP, DNS, DHCP, RTP, RTSP, NTP, and More
- Electronic Image Stabilization (EIS)
- Pan/Tilt and Enclosure with Integrated Optics Package (IOP) or Pressurized Integrated Optics Cartridge (IOC)
- 16 Preset Tours, 256 Presets, 32 Window Blanks

Network Positioning System

Pelco takes its industry-leading Esprit® Series positioning system into the world of high definition. Esprit HD delivers crystal-clear, live streaming images over the Internet using a standard Web browser (Microsoft® Internet Explorer® or Mozilla® Firefox®). With six times the resolution of standard definition positioning systems, Esprit HD is an ideal solution to view details such as faces, license plates, tattoos, or other specific features.

Esprit HD supports High-Profile H.264 compression, a vast improvement in quality over MPEG-4 and 20 times more efficient than MJPEG. The positioning system features open architecture connectivity for third-party software recording solutions allowing integration into virtually any IP-based HD system. It is also compatible with Digital Sentry® video management systems. As with all Pelco IP camera solutions, Esprit HD is Endura Enabled™ to record, manage, configure, and view multiple live streams. When connected to an Endura® HD network-based video security system, the positioning system has access to EnduraStor™ and EnduraView™ for optimized image quality and bandwidth efficiency.

Built-In Analytics

Pelco Analytics enhance the flexibility and performance of Esprit HD. Nine Pelco behaviors are preloaded and included as standard features. Pelco behaviors can be configured and enabled using a standard Web browser, and they are compatible with Endura or a third-party system that supports alarms using Pelco's API.



- Integrated Window Wiper with Configurable Delay and Shut-Off (ES5230-1x Models)
- Open IP Standards
- ONVIF Profile S Conformant

Web Interface

Esprit HD uses a standard Web browser for powerful remote setup and administration.

Window Blanking

Window blanking is used to conceal user-defined privacy areas that cannot be viewed by an operator. Esprit HD supports up to 32 blanked windows. A blanked area will appear on the screen as a solid gray window.

Video Systemization

Esprit HD easily connects to Pelco IP and hybrid systems such as Endura version 2.0 (or later) and Digital Sentry version 7.3 (or later). The camera is also compatible with Digital Sentry NVs (DS NVs), a full-featured video management software, which is available as a free download at www.pelco.com. DS NVs includes four free Pelco IP licenses and allows for the management of video from up to 64 cameras.

Esprit HD features open architecture connectivity to third-party software. Pelco offers an application programming interface (API) and software developer's kit (SDK) for interfacing with Pelco's IP cameras.



by Schneider Electric



International Standards Organization Registered Firm; ISO 9001 Quality System



C4008 / REV 4-19-17

TECHNICAL SPECIFICATIONS

Pelco's ES5230 Esprit® HD Positioning System features a pan/tilt, enclosure, and either an Integrated Optics Package (IOP) or a pressurized Integrated Optics Cartridge (IOC) in a single, easy-to-install system. Options include IOP with or without wiper and IOC models with wiper.

A powder-coated, aluminum construction makes the ES5230 Series ideal for either indoor or outdoor applications. The system has an absolute operating temperature range of -45° to 50°C (-50° to 122°F). Within two hours after power-up, the entire unit can de-ice and be operational from a temperature of -25°C (-13°F).

The ES5230 Series variable pan and tilt speeds range from 0.1 to 40 degrees per second in manual pan mode, and 0.1 to 30 degrees per second in manual tilt. Pan preset and turbo speeds are 100 degrees per second. Tilt preset speed is 30 degrees per second.

The ES5230 Series system's IOC contains dry nitrogen pressurized to 10 psig, which protects the environment inside the cartridge eliminating internal condensation and corrosion. Sensors strategically placed in the cartridge send an "Alert" message if pressure drops below factory-set acceptable limits. The IOC is factory assembled and installed in the ES5230 Series systems. All labor intensive procedures of setting up the camera, lens and charging the unit with dry nitrogen are eliminated. The miniature size of the cartridge decreases the future need for maintenance and increases the overall reliability of the pressurized unit.

Many models include a window wiper. The wiper is completely integrated into the enclosure and does not interfere with the viewing range of the system. The wiper can be configured to delay between wipes and to automatically shut off after a specified period. The wiper design also allows for easy replacement of the wiper blade. A built-in heater, window defroster/defogger, sun shroud, and insulation blanket are standard features on the ES5230 units, which also includes an open collector auxiliary output to control external devices.

The systems are available with an input voltage of 24 VAC or with a selectable power source of 120/230 VAC. The ES5230 Series also has a power-up recovery mode that allows the user to specify what operation the system will resume whenever the power is cycled.

Electronic Image Stabilization (EIS)

Electronic image stabilization (EIS) is a feature of the camera that can help compensate for some frequencies of vibration. In all cases, care should be taken to ensure that any positioning system is mounted to a rigid location.

The default for EIS is OFF. The user can turn EIS ON if vibration is affecting image quality. Although EIS can reduce the impact of vibration on image quality, it cannot correct for all levels of vibration. Other measures should be taken to isolate the camera from the source of the vibration or to seek a more rigid mounting location.

PELCO ANALYTICS

ES5230 Series includes nine user-configurable behaviors. The camera is capable of running up to three behaviors at the same time; although, the number of behaviors is limited to the available processing power of the camera and the type of analytic being used.

Note: Available processing power is determined by the settings for compression standards, resolution, image rate, bit rate, and analytic configuration.

For each behavior, you can create several custom profiles that contain different camera settings. With these profiles, you can set up different scenarios for the behavior, which will automatically detect and trigger alarms when specific activity is detected.

Pelco Analytics are configured and enabled using a standard Web browser, and Pelco behavior alarms are compatible with Endura or a third-party system that supports Pelco's API system.

Multiple Pelco behaviors can be scheduled to work during a certain time or condition. For example, during the day, a camera can be configured with Object Counting to count the number of people that enter a lobby door. At night, the operator can change the profile to Camera Sabotage to trigger an alarm if a camera is moved or obstructed. Available Pelco behaviors include:

- **Abandoned Object:** Detects objects placed within a defined zone and triggers an alarm if the object remains in the zone longer than the user-defined time allows. An airport terminal is a typical installation for this behavior. This behavior can also detect objects left behind at an ATM, signaling possible card skimming.
- **Adaptive Motion Detection:** Detects and tracks objects that enter a scene and then triggers an alarm when the objects enter a user-defined zone. This behavior is primarily used in outdoor environments with light traffic to reduce the number of false alarms caused by environmental changes.
- **AutoTracker:** Detects and tracks movement in the field of view. When the AutoTracker behavior is configured, the system automatically pans and tilts to follow the moving object until the object stops or disappears from the monitored area.
- **Camera Sabotage:** Detects contrast changes in the field of view. An alarm is triggered if the lens is obstructed by spray paint, a cloth, or a lens cap. Any unauthorized repositioning of the camera also triggers an alarm.
- **Directional Motion:** Generates an alarm in a high traffic area when a person or object moves in a specified direction. Typical installations for this behavior include an airport gate or tunnel where cameras can detect objects moving in the opposite direction of the normal flow of traffic or an individual entering through an exit door.
- **Loitering Detection:** Identifies when people or vehicles remain in a defined zone longer than the user-defined time allows. This behavior is effective in real-time notification of suspicious behavior around ATMs, stairwells, and school grounds.
- **Object Counting:** Counts the number of objects that enter a defined zone. This behavior can be used to count the number of people at a store entrance/exit or inside a store where the traffic is light. This behavior is based on tracking and does not count people in a crowded setting.
- **Object Removal:** Triggers an alarm if an object is removed from a user-defined zone. This behavior is ideal for customers who want to detect the removal of high value objects, such as a painting from a wall or a statue from a pedestal.
- **Stopped Vehicle:** Detects vehicles stopped near a sensitive area longer than the user-defined time allows. This behavior is ideal for airport curbside drop-offs, parking enforcement, suspicious parking, traffic lane breakdowns, and vehicles waiting at gates.

TECHNICAL SPECIFICATIONS

CAMERA/OPTICS

Sensor Type	1/2.8-inch Type Exmor CMOS Sensor
Optical Zoom	30X
Digital Zoom	12X
Maximum Resolution	1920 x 1080
Lens	f/1.6 ~ f/4.7, focal length 4.3 mm (wide) ~ 129.0 mm (tele)
Horizontal Angle of View	59.5° (wide) ~ 2.1° (tele)
Aspect Ratio	16:9
Light Sensitivity*	
Color (33 ms)	0.65 lux
Color (250 ms)	0.07 lux
Mono (33 ms)	0.20 lux
Mono (250 ms)	0.015 lux
Day/Night Capabilities	Yes
IR Cut Filter	Yes
Wide Dynamic Range	80 dB
Iris Control	Auto iris with manual override
Backlight Compensation	Yes
Automatic Gain Control	Yes
Active Noise Filtering	Yes
Electronic Image	
Stabilization (EIS)	Yes

*Sensitivity in lux for 90% reflectance, f/1.6 (wide angle), 28 dB gain at 30 IRE (30% of signal level) with Sensitivity Boost OFF; 4X improvement to sensitivity with Sensitivity Boost ON

SOFTWARE FEATURES

- Multilingual Menus (English, Spanish, Portuguese, Italian, German, French, Russian, Turkish, Arabic, Chinese, and Korean).
- 32 Window Blanks, Configurable in Size[†]
- Configurable Park with Actions
- Proportional Pan/Tilt Continually Decreases Pan/Tilt Speeds in Proportion to Depth of Zoom

[†] Using the maximum number of window blanks in a single view can affect camera performance and could interrupt certain camera functions.

 VALUES IN PARENTHESES ARE INCHES; ALL OTHERS ARE CENTIMETERS.

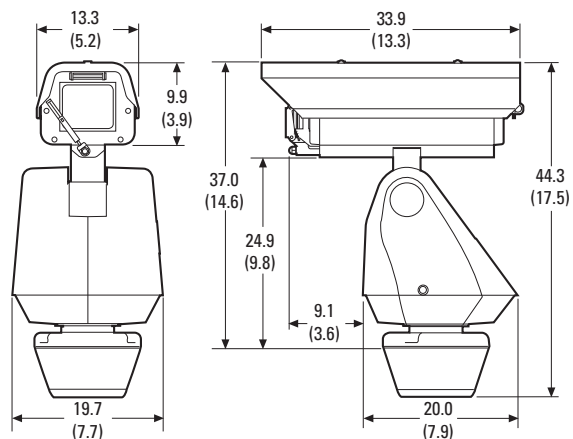

TECHNICAL SPECIFICATIONS

VIDEO

Video Encoding	H.264 High, Main, or Base profiles and MJPEG
Video Streams	Up to 2 simultaneous streams; the second stream is variable based on the setup of the primary stream
Frame Rate	Up to 30, 25, 15, 12.5, 10, 8.333, 7.5, 6, 5, 3, 2.5, 2, 1 (depending on the coding, resolution, and stream configuration)

Available Resolutions	Resolution			H.264 High Profile (IP GOP structure)		
	MPx	Width	Height	Aspect Ratio	Maximum IPS	Recommended Bit Rate (Mbps)
	2.07	1920	1080	16:9	30	3.50
	0.92	1280	720	16:9	30	2.90
	0.59	800	448	16:9	30	1.80
	0.52	640	352	16:9	30	1.15
	0.23	480	272	16:9	30	0.75
	0.06	320	176	16:9	30	0.35

Supported Protocols	TCP/IP, UDP/IP (Unicast, Multicast IGMP), UPnP, DNS, DHCP, RTP, RTSP, NTP, IPv4, IPv6*, SNMP v2c/v3, QoS, HTTP, HTTPS, LDAP (client), SSH, SSL, SMTP, FTP, and 802.1x (EAP)
---------------------	---

Users	
Unicast	Up to 20 simultaneous users depending on resolution settings (2 guaranteed streams)
Multicast	Unlimited users H.264
Security Access	Password protected
Software Interface	Web browser view and setup
Pelco System Integration	Endura 2.0 (or later) Digital Sentry 7.3 (or later)
Open API	Pelco API or ONVIF Profile S
Minimum System Requirements	
Processor	Intel® Core™ i3 Processor, 2.4 GHz
Operating System	Windows® 7 (32-bit and 64-bit) with DirectX® 11, Windows XP Service Pack 3 with DirectX 9.0c, or Mac® OS X 10.4 (or later)
Memory	4 GB RAM
Network Interface Card	100 megabits (or greater)
Monitor	Minimum of 1024 x 768 resolution, 16- or 32-bit pixel color resolution
Web Browser	Internet Explorer 8.0 (or later) or Firefox 3.5 (or later); Internet Explorer 8.0 (or later) is recommended for configuring analytics
Media Player†	Pelco Media Player‡ or QuickTime® 7.6.5 for Windows XP and Windows 7; or QuickTime 7.6.4 for Mac OS X 10.4 (or later)

*Supports mixed IPv4 and IPv6 installations, but not IPv6-only deployments.

†This product is not compatible with QuickTime version 7.6.4 for Windows XP or Windows Vista. If you have this version installed on your PC, you will need to upgrade to QuickTime version 7.6.5.

‡Pelco Media Player is recommended for control, smoothness, and reduced latency as compared to QuickTime.

TECHNICAL SPECIFICATIONS

ANALYTICS

Required Systems for Pelco Analytics	WS5200 Advanced System Management Software on an Endura 2.0 (or later) system
Pelco Interface	The Pelco API can transmit behavior alarm data to third-party applications, available at pdn.pelco.com
Open API	

GENERAL

Construction	Die-cast, extruded and sheet aluminum; stainless steel hardware	
Finish	Gray polyester powder coat	
Operating Temperature	-45° to 50°C (-50° to 122°F) ambient for sustained system operation or 74°C (165.2°F) absolute maximum ambient per NEMA TS-2; within two hours after power-up, the entire unit can de-ice and be operational from a temperature of -25°C (-13°F)	
Operating Environment	Will remain operational in 145 kph (90 mph) wind conditions; withstands 209 kph (130 mph)	
Storage Temperature	-20° to 60°C (-4° to 140°F)	
Operating Humidity	Standard with IOP: 5 to 90% relative humidity (noncondensing) Standard with IOC: 5 to 100% relative humidity (condensing)	
Weight	Pedestal Adapter	Wall Mount
Unit		
Standard with IOP	9.0 kg (20 lb)	9.9 kg (22 lb)
With Wiper and IOP	9.5 kg (21 lb)	10.4 kg (23 lb)
With Wiper and IOC	10.0 kg (22 lb)	11.0 kg (24 lb)
Shipping		
Standard with IOP	11.3 kg (25 lb)	12.6 kg (28 lb)
With Wiper and IOP	11.7 kg (26 lb)	13.1 kg (29 lb)
With Wiper and IOC	12.3 kg (27 lb)	13.6 kg (30 lb)

PRESSURIZED INTEGRATED OPTICS CARTRIDGE (IOC)

- Pressurized to 10 psig, Nominal (Sea Level, 21°C [70°F])
- Internal Sensor for Low Pressure Alarm
- Designed to IP67 Standards
- U.S. Patent D472,260

MECHANICAL

Variable Speed	0.1° to 100°
Preset Accuracy	±0.1°
Pan Movement	360° continuous pan rotation
Vertical Tilt	Unobstructed +36° to -85°
Manual Pan/Tilt Speeds	
Pan	0.1° to 40°/sec manual operation
Tilt	0.1° to 30°/sec manual operation
Preset Speeds	
Pan	100°/sec
Tilt	30°/sec
Wind Speeds	
Full Motion Control	0-52 knots (60mph/97kph)
Limited Speed Control	52-78 knots (90mph/145kph)
Hold Position	78-96 knots (110mph/177kph)
Survives	96-130 knots (150mph/241kph)

ELECTRICAL

Input Voltage	24, 120, or 230 VAC, 50/60 Hz; switch selectable for 120/230 VAC inputs
Input Voltage Range	±10%
Power Consumption	Maximum 70 VA per system
Heater and Defroster	Thermostatically controlled
Electrical Connections	
24 VAC	Screw terminals for power and open collector auxiliary output. RJ-45 connector for data
120/230 VAC	RJ-45, 2 power source connections made at mount location with wire splices and 1 ground wire splice; 2 wire splices for Aux 2 output
Aux 2	Open collector output with 2-second activation; connected relay must require no more than 32 VDC and 40 mA to energize relay coil; wire length between Esprit and relay must be less than 3 m (9.84 ft)

CERTIFICATIONS/RATINGS

- CE, Class A
- FCC, Class A
- KCC
- UL/cUL Listed
- C-Tick
- NEMA TS-2 (Temp.) para 2.2.7.3 - 2.2.7.7
- Meets NEMA Type 4X and IP66 Standards
- ONVIF Profile S
- Cisco® Medianet Media Services Proxy 2.0 compatible

REPLACEMENT INTEGRATED OPTICS PACKAGE (IOP)

The following IOP model is a replacement component only; it is not interchangeable.

IOP-30	Esprit HD 1080P resolution camera and lens module, 30X replacement IOP module
--------	---

REPLACEMENT PRESSURIZED INTEGRATED OPTICS CARTRIDGE (IOC)

The following IOC models are replacement components only; they are not interchangeable.

IOC-30	Esprit HD 1080P resolution camera and lens module, 30X replacement pressurized IOC module
--------	---

OPTIONAL ACCESSORIES

ES-REPLBLADE-2	Package of 2 window wiper replacement blades
ES-REPLBLADE-10	Package of 10 window wiper replacement blades

MODEL NUMBERS

MODELS

Enclosure Type	Pedestal Mount*		Wall Mount†	
	24 VAC	120/230 VAC	24 VAC	120/230 VAC
With IOP	ES5230-02N	ES5230-05N	ES5230-02W	ES5230-05W
With IOP and Wiper	ES5230-12N	ES5230-15N	ES5230-12W	ES5230-15W
With IOC and Wiper	ES5230-12NP	ES5230-15NP	ES5230-12WP	ES5230-15WP

*Pedestal mount models include Esprit EPP pedestal adapter plate. Use with PM2000/PM2010 mount (not supplied) for pedestal application.

† Wall mount models include Esprit EWM wall mount. Optional mounting adapters for corner, pole, and parapet applications are available.

OPTIONAL MOUNTS AND ADAPTERS

ECM100	Corner mount adapter for use with EWM wall mount
EPM	Pole mount adapter for use with EWM wall mount
EA4348	EWM-to-Legacy adapter; use with PP4348 parapet mount
PM2000/PM2010	Pedestal mount with cable feedthrough. For use with Esprit systems with EPP pedestal adapter plate.

RECOMMENDED POWER SUPPLIES

MCS Series	Multiple 24 VAC camera power supply, indoor
WCS Series	Single/multiple 24 VAC camera power supply, outdoor

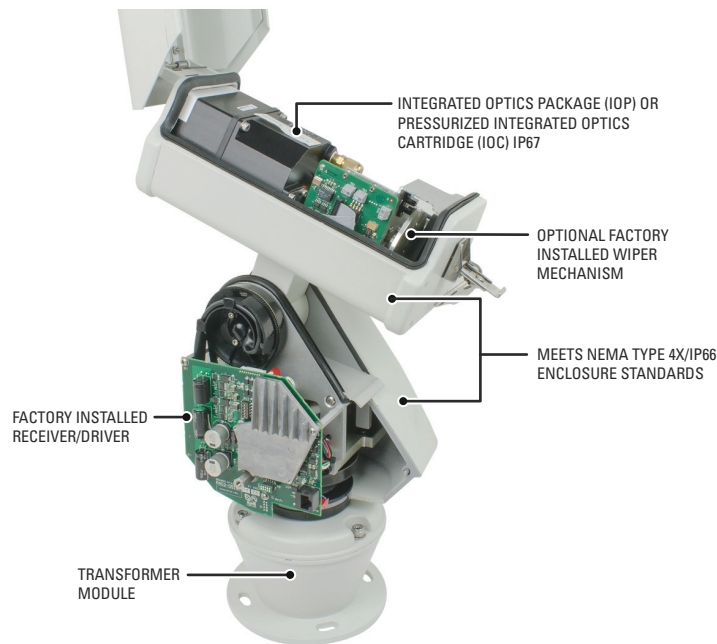

Pelco by Schneider Electric

3500 Pelco Way, Clovis, California 93612-5699 United States

USA & Canada Tel (800) 289-9100 Fax (800) 289-9150

International Tel +1 (559) 292-1981 Fax +1 (559) 348-1120

www.pelco.com www.pelco.com/community

Pelco, the Pelco logo, and other trademarks associated with Pelco products referred to in this publication are trademarks of Pelco, Inc. or its affiliates. ONVIF and the ONVIF logo are trademarks of ONVIF Inc. All other product names and services are the property of their respective companies.

Product specifications and availability are subject to change without notice.

©Copyright 2016, Pelco, Inc. All rights reserved.