



# FREE FLOAT<sup>®</sup> STEAM TRAP

## MODEL J7.5X

### FREE FLOAT STEAM TRAP WITH THERMOSTATIC AIR VENTING

#### Benefits

**Extremely durable, inline repairable free float trap with tight shut-off for drainage of medium to large size heating and process loads.**

1. Self-modulating free float provides soft, continuous, smooth, low velocity discharge, as process loads vary, for maximum performance.
2. Unique rotational seating design eliminates concentrated wear to provide long maintenance-free service life.
3. Durable thermostatic unit automatically vents air for exceptional start-up and performance.
4. Easy, inline access to internal parts simplifies cleaning and lowers maintenance costs.
5. Rugged float construction with up to 1500 psig hydraulic shock rating ensures excellent resistance to water hammer.
6. Built-in screen with large surface area ensures extended trouble-free service.



U.S. Pat. 5,833,135

#### Specifications

Model	J7.5X	
Connection	<b>Flanged</b>	
Size (in)	<b>1 1/2, 2</b>	
Orifice No.	1, 2, 5, 10, 14, 18	
Maximum Operating Pressure (psig) PMO	15, 30, 75, 150, 200, 250	
Maximum Differential Pressure (psi) ΔPMX	15, 30, 75, 150, 200, 250	
Minimum Operating Pressure (psig)	Vacuum	
Maximum Operating Temperature (°F) TMO	428	
Maximum Allowable Pressure (psig) PMA	250	
Maximum Allowable Temperature (°F) TMA	428	

Connections and sizes in bold are standard



To avoid abnormal operation, accidents or serious injury, DO NOT use this product outside of the specification range. Local regulations may restrict the use of this product to below the conditions quoted.

No.	Description	Material	ASTM/AISI#	JIS
①	Body	Cast Iron	A126 Cl.B	FC250
②	Cover	Cast Iron	A126 Cl.B	FC250
③ <sup>F</sup>	Float	Stainless Steel	AISI316L	SUS316L
④ <sup>R</sup>	Orifice	—	—	—
⑤ <sup>MR</sup>	Orifice O-Ring	Ethylene Propylene Rubber	D2000CA	EPR
⑥	Orifice Holder Plug	Ductile Cast Iron	A536 Gr. 65-45-12	FCD450
⑦ <sup>MR</sup>	Holder Plug Gasket	Fluorine Resin	PTFE	PTFE
⑧ <sup>R</sup>	Screen	Stainless Steel	AISI430	SUS430
⑨	Screen Holder	Stainless Steel	AISI304	SUS304
⑩	Screen Holder Retainer	Stainless Steel	AISI304	SUS304
⑪	Snap Ring	Stainless Steel	AISI304	SUS304
⑫ <sup>MR</sup>	Cover Gasket	Graphite/Stainless Steel	—/AISI316L	—/SUS316L
⑬	Cover Bolt	Carbon Steel	AISI1045	S45C
⑭ <sup>R</sup>	X-element	Stainless Steel	—	—
⑮ <sup>R</sup>	Spring Clip	Stainless Steel	AISI304	SUS304
⑯ <sup>R</sup>	X-element Guide	Stainless Steel	AISI304	SUS304
⑰ <sup>R</sup>	X-element Cover	Stainless Steel	AISI304	SUS304
⑱ <sup>R</sup>	Snap Ring	Stainless Steel	AISI304	SUS304
⑲ <sup>R</sup>	Air Vent Valve Seat	Stainless Steel	AISI420F	SUS420F
⑳	Plug	Carbon Steel	A6	SS400
㉑	Connector	Stainless Steel	AISI416	SUS416
㉒	Nameplate	Stainless Steel	AISI304	SUS304
㉓	Drain Plug	Carbon Steel	A6	SS400

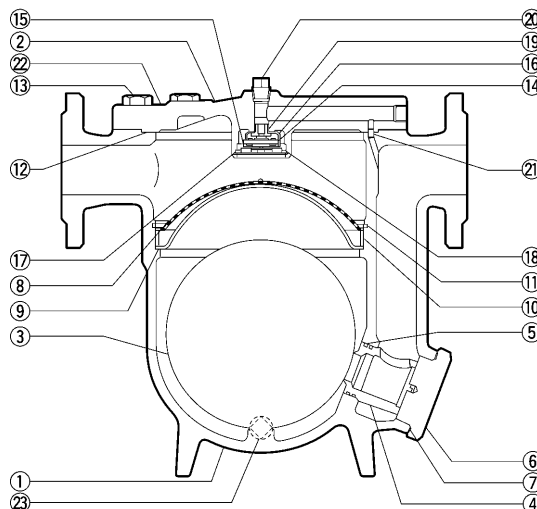

\* Equivalent  
Replacement kits available: (M) maintenance parts, (R) repair parts, (F) float

**Dimensions**

● **J7.5X** Flanged

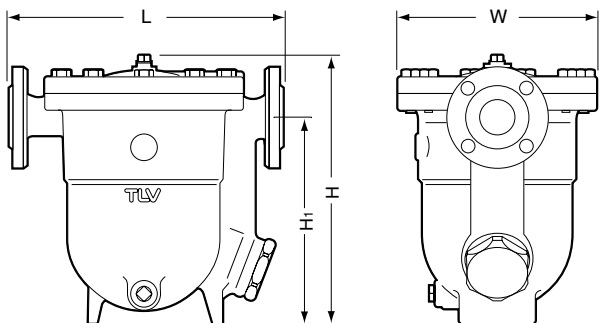

**J7.5X** Flanged (in)

Size	L		H	H <sub>1</sub>	φW	Weight* (lb)
	Connects to ASME Class					
	125FF	250RF				
1½	15	15 <sup>7</sup> / <sub>16</sub>	15 <sup>5</sup> / <sub>8</sub>	12 <sup>1</sup> / <sub>16</sub>	11 <sup>7</sup> / <sub>16</sub>	94
2	15 <sup>7</sup> / <sub>16</sub>	16	15 <sup>13</sup> / <sub>16</sub>			100

Other standards available, but length and weight may vary  
\* Weight is for Class 250 RF

Flange classes in bold are standard

**Discharge Capacity**

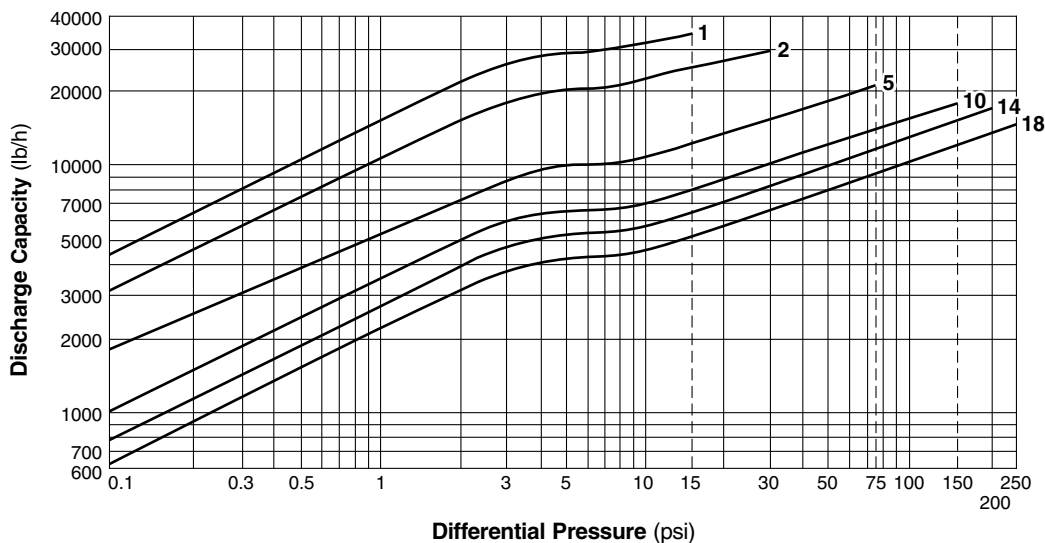

1. Line numbers within the graph refer to orifice numbers.
2. Differential pressure is the difference between the inlet and outlet pressure of the trap.
3. Capacities are based on continuous discharge of condensate 11°F below saturated steam temperature.
4. Recommended safety factor: at least 1.5.

**CAUTION** DO NOT use traps under conditions that exceed maximum differential pressure, as condensate backup will occur!

**CAUTION** DO NOT DISASSEMBLE OR REMOVE THIS PRODUCT WHILE IT IS UNDER PRESSURE. Allow internal pressure of this product to equal atmospheric pressure and its surface to cool to room temperature before disassembling or removing. Failure to do so could cause burns or other injury. READ INSTRUCTION MANUAL CAREFULLY

**TLV CORPORATION**

13901 South Lakes Drive, Charlotte, NC 28273-6790  
Phone: 704-597-9070 Fax: 704-583-1610  
E-mail: [tlv@tlvengineering.com](mailto:tlv@tlvengineering.com)  
For Technical Service 1-800 "TLV TRAP"



Manufacturer  
**TLV CO., LTD.**  
Kakogawa, Japan  
is approved by LROA Ltd. to ISO 9001/14001

ISO 9001/ISO 14001

