



TEMPERATURE CONTROL STEAM TRAP

MODEL LEX3N-TZ

FIXED TEMPERATURE DISCHARGE THERMOSTATIC TRAP TO CONTROL TEMPERATURE

Benefits

Steel-bodied bimetal thermostatic steam trap for accurate control of condensate discharge temperature. For use with steam tracing lines, storage tanks, instrument enclosures, steam trap air venting, and freeze protection of condensate lines.*

1. Maintains temperature control at preset levels between 120 and 390 °F by setting the valve closing temperature.
2. Provides maximum energy utilization of the sensible heat in condensate that is wasted.
3. Includes a built-in device for removing scale and build-up from the valve seat.
4. Lowers cost of heating instrument enclosures and eliminates need for heat lamps.
5. Built-in, easy-to-clean screen protects internals to extend trouble-free service life.
6. Inline repairable to lower maintenance costs.
7. Can be used as an automatic non-freeze valve.
8. Overexpansion mechanism prevents damage to the bimetal element and ensures long service life.

* See 'Applications' on page 2.



Specifications

Model	LEX3N-TZ		
Connection	Screwed	Socket Weld	Flanged
Size (in.)	3/8, 1/2, 3/4, 1	3/8, 1/2, 3/4, 1	1/2, 3/4, 1
Condensate Temperature Setting Range (°F)*	120 - 390* (see table right)		
Maximum Operating Pressure (psig) PMO	650		
Minimum Operating Pressure (psig)	15		
Maximum Operating Temperature (°F) TMO	662		
Maximum Allowable Pressure (psig) PMA	900		
Maximum Allowable Temperature (°F) TMA	800		

* Set temperature should be more than 27 °F below the steam saturation temperature.

Connections and sizes in bold are standard

CAUTION To avoid abnormal operation, accidents or serious injury, DO NOT use this product outside of the specification range. Local regulations may restrict the use of this product to below the conditions quoted.

No.	Description	Material	ASTM/AISI*	JIS
①	Body	Cast Stainless Steel	A351 Gr. CF8	—
②	Cover	Stainless Steel	AISI303	SUS303
③ ^R	Valve Stem	Stainless Steel	AISI420	SUS420J2
④	Adjusting Screw	Stainless Steel	AISI303	SUS303
⑤ ^R	Bimetal Element	Bimetal	—	—
⑥ ^R	Washer	Stainless Steel	AISI304	SUS304
⑦ ^R	Valve Seat	Stainless Steel	AISI303	SUS303
⑧ ^{MR}	Valve Seat Gasket	Stainless Steel	AISI316L	SUS316L
⑨ ^R	Overexpansion Spring	Stainless Steel	AISI304	SUS304
⑩ ^R	Return Spring	Stainless Steel	AISI304	SUS304
⑪ ^R	Snap Ring	Stainless Steel	AISI304	SUS304
⑫ ^R	Spring Pin	Stainless Steel	AISI304	SUS304
⑬ ^{MR}	Seal Ring	Fluorine Rubber	D2000HK	FPM
⑭ ^R	Screen inside/outside	Stainless Steel	AISI430/304	SUS430/304
⑮	Lock Nut	Stainless Steel	AISI303	SUS303
⑯	Cap Nut	Cast Stainless Steel	A351 Gr. CF8	—
⑰ ^{MR}	Cover Gasket	Stainless Steel	AISI316L	SUS316L
⑱	Nameplate	Stainless Steel	AISI304	SUS304
⑲ ^R	Spring Guide	Stainless Steel	AISI304	SUS304
⑳ ^R	Thrust Plate	Stainless Steel	AISI304	SUS304
㉑ ^{MR}	Cap Nut Gasket	Graphite	—	—
㉒	Flange (shown overleaf)	Cast Stainless Steel	A351 Gr. CF8	—

● Temperature Setting Range

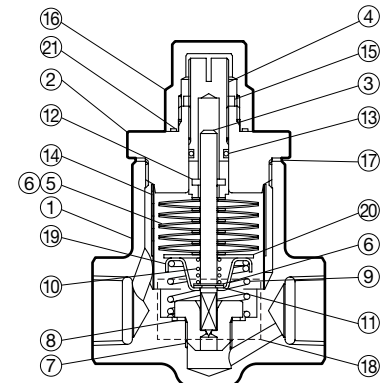
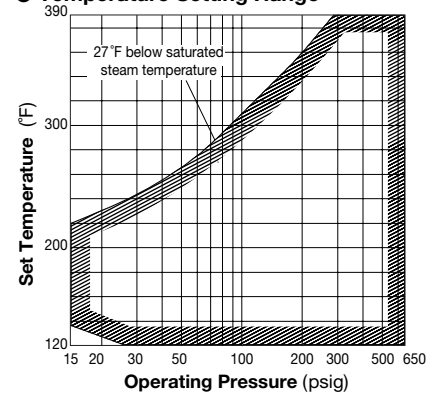

* Equivalent Replacement kits available: (M) maintenance parts, (R) repair parts

Dimensions

● **LEX3N-TZ**
Screwed

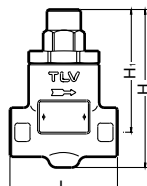

● **LEX3N-TZ**
Socket Weld

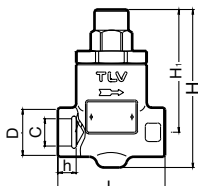

● **LEX3N-TZ**
Flanged

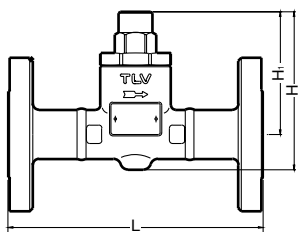

LEX3N-TZ Screwed* / Socket Weld** (in)

Size	L	H	H ₁	φD	φC	h	Weight (lb)
3/8	2 3/4	4 1/16	3 1/8	1 1/4	0.690	15/32	1.8
					0.855		
3/4	3 1/8	4 7/16	3 17/32	1 13/16	1.065	35/64	2.9
1					1.330		2.6

* NPT, other standards available

** ASME B16.11-2005, other standards available

LEX3N-TZ Flanged (in)

Size	L		H	H ₁	Weight* (lb)
	Connects to ASME Class				
	150RF	300RF			
1/2	5 3/4	5 3/4	4 1/16	3 1/8	5.1
3/4	6 17/32	6 17/32	4 7/16	3 17/32	7.3
1	6 5/16	7 5/16			8.8

Other standards available, but length and weight may vary

* Weight is for class 300 RF

Sizing Charts

Estimation of Discharge Capacity.

Example: The flow rate of condensate discharging from 100 psig to atmosphere at 200 °F from a trap set to 230 °F is determined as follows:

Step 1: Use the discharge capacity graph.

From the 200 °F condensate temperature on the horizontal axis, follow a vertical line until it intersects the 230 °F set temperature curve (point A).

From A, follow a horizontal line across to the vertical axis (point B), and read the discharge capacity, 440 lb/h.

Step 2: Use the correction graph.

Because the discharge capacity graph is based on a steam pressure of 300 psig, a correction factor must be used to adjust the discharge capacity value to the actual differential pressure at the trap.

Read up from 100 psi on the horizontal axis to the diagonal line (point C), then across to the correction factor (point D), 0.57.

Multiply the discharge capacity obtained in step 1 by the correction factor to get the actual discharge capacity:

440 °F × 0.57 = 250 lb/h.

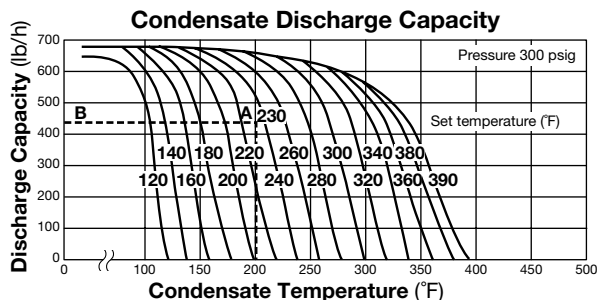

Recommended safety factor: at least 2.

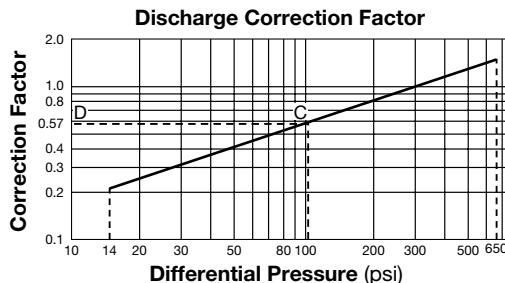

Differential pressure is the difference between the inlet and outlet pressure of the trap.

Applications

DO NOT USE on any application except steam tracing lines, storage tank coils, instrument enclosures, steam trap venting, and freeze protection of condensate lines.

SUITABLE for steam tracing lines or storage tank coils **ONLY IF** the required product viscosity will be maintained when the condensate is subcooled at least 27 °F, even to the point of the condensate having a lower temperature than the product temperature.

SUITABLE for use on instrument enclosures **ONLY IF** the steam or condensate temperature in the enclosures will **NOT** damage the instrument.

SUITABLE for use as an external air vent for TLV steam traps, or as a non-freeze valve for freeze protection of condensate lines.



DO NOT REMOVE CAP NUT OR COVER WHILE TRAP IS UNDER PRESSURE.
Allow trap body temperature to cool to room temperature before removing cap nut or cover.
Failure to do so may result in burns or other injury. READ INSTRUCTION MANUAL CAREFULLY.

TLV CORPORATION

13901 South Lakes Drive, Charlotte, NC 28273-6790
Phone: 704-597-9070 Fax: 704-583-1610
E-mail: tlv@tlvengineering.com
For Technical Service 1-800 "TLV TRAP"



Manufacturer

TLV CO., LTD.

Kakogawa, Japan

is approved by LRQA Ltd. to ISO 9001/14001

ISO 9001/ISO 14001

