



AIR TRAP

MODEL TATSU2

HIGH-CAPACITY AIR TRAP DRAINS HIGHLY VISCOUS OIL AND CONDENSATE

Benefits

Large-capacity air trap automatically drains condensate and oil from compressed air systems. Recommended installations include receiver tanks, after coolers and air mains.

1. Unique design allows self-cleaning of the trap interior during each discharge.
2. Large size orifice eliminates problems due to dirt and oil accumulation.
3. Pilot valve supported by coil spring reduces wear of the sealing surface.
4. Y-strainer and blow down valve allow cleaning during operation to ensure trouble-free service.
5. Internal parts are made of stainless steel and other corrosion-resistant materials.
6. Optional flow indicator at the trap inlet is available to verify condensate flow.



Specifications

Model		TATSU2
Connection		Screwed
Size (in)		1
Maximum Operating Pressure (psig)	PMO	150
Maximum Differential Pressure (psi)	Δ PMX	150
Minimum Differential Pressure (psig)		30
Maximum Operating Temperature ($^{\circ}$ F)	TMO	176
Maximum Allowable Pressure (psig)	PMA	150
Maximum Allowable Temperature ($^{\circ}$ F)	TMA	302
Applicable Fluid*		Air

* Do not use for toxic, flammable or otherwise hazardous fluids.



To avoid abnormal operation, accidents or serious injury, DO NOT use this product outside of the specification range. Local regulations may restrict the use of this product to below the conditions quoted.

No.	Description	Material	ASTM/AISI*	JIS
①	Body	Cast Iron	A126 Cl.B	FC250
②	Cover	Cast Iron	A126 Cl.B	FC250
③	Outlet Union	Cast Iron	A126 Cl.B	FC250
④	Float Cover	Polypropylene	PP	PP
⑤	Float	Stainless Steel	AISI316L	SUS316L
⑥	Float Holder	Polypropylene	PP	PP
⑦	Main Valve Seat	Stainless Steel	AISI303	SUS303
⑧	Piston	Stainless Steel	AISI303	SUS303
⑨	Pilot Valve Seat	Fluorine Resin	PTFE	PTFE
⑩	Main Valve	Nitrile Rubber/Stainl. Stil.	D2000BF/AISI304	NBR/SUS304
⑪	Pilot Valve	Nitrile Rubber/Stainl. Stil.	D2000BF/AISI303	NBR/SUS303
⑫	Cover Gasket	Fiber-Rubber Compound	—	—
⑬	Outlet Union Gasket	Fiber-Rubber Compound	—	—
⑭	Cover Bolt	Cr-Mo Steel	AISI4135	SMC435
⑮	Trap Support	Carbon Steel	A6	SS400
⑯	Outlet Elbow	Malleable Cast Iron	A47 Gr.32510	FCMB270
⑰	Nipple	Malleable Cast Iron	A47 Gr.32510	FCMB270
⑱	Y-Strainer	Cast Stainless Steel	A351 Gr.CF8	—
⑲	Strainer Blow Valve	Malleable Cast Iron	A47 Gr.32510	FCMB270
⑳	Foundation Bolt/Nut	Carbon Steel	A6	SS400

* Equivalent

Connections and sizes in bold are standard

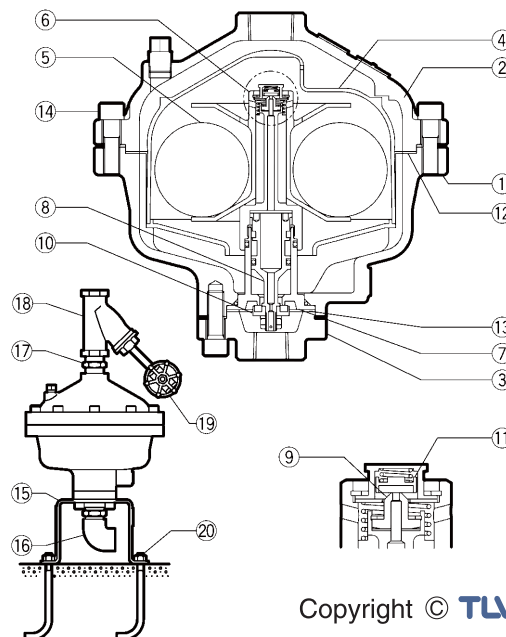

Dimensions

● **TATSU2** Screwed

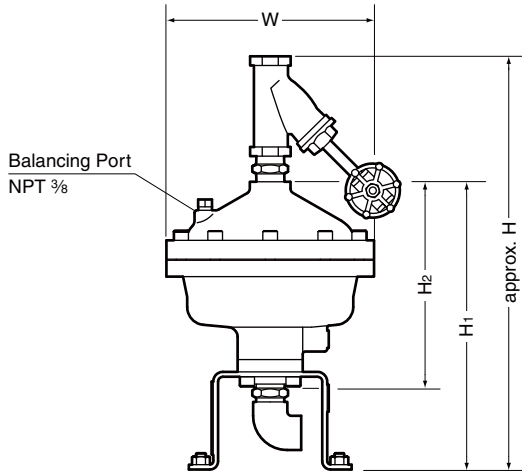

TATSU2 Screwed* (in)

Size	H	H ₁	H ₂	φW	Weight (lb)
1	19½	13 ¹⁵ / ₁₆	9 ¹³ / ₁₆	10	46

* NPT, other standards available

NOTE:

A pressure-balancing line must be connected to the air system, from the balancing port at the top of the trap to a place above any possible condensate accumulation in the system.

Discharge Capacity

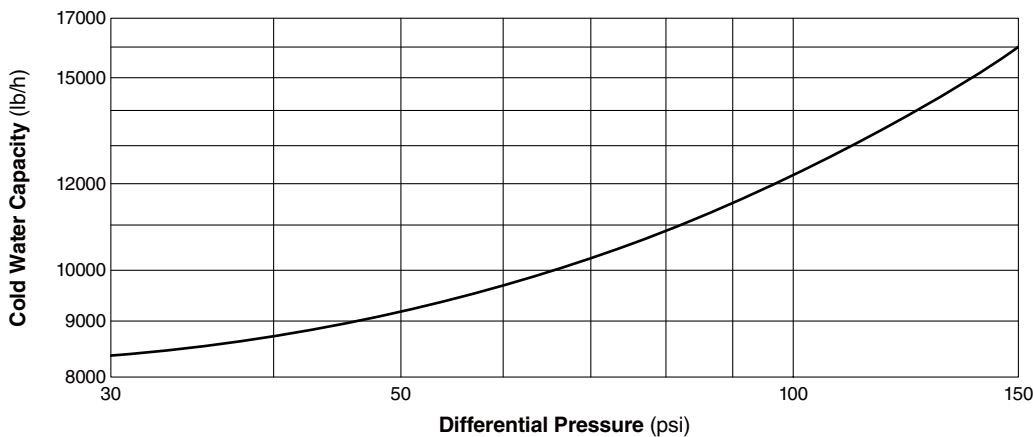

1. Differential pressure is the difference between the inlet and outlet pressure of the trap.
2. The chart is applicable to condensate below 176°F.
3. The discharge capacity is for a liquid with specific gravity of 1.
4. Recommended safety factor: at least 1.5.

CAUTION DO NOT use traps under conditions that exceed maximum differential pressure, as condensate backup will occur!

CAUTION DO NOT DISASSEMBLE OR REMOVE THIS PRODUCT WHILE IT IS UNDER PRESSURE. Allow internal pressure of this product to equal atmospheric pressure and its surface to cool to room temperature before disassembling or removing. Failure to do so could cause burns or other injury. READ INSTRUCTION MANUAL CAREFULLY

TLV CORPORATION

13901 South Lakes Drive, Charlotte, NC 28273-6790
 Phone: 704-597-9070 Fax: 704-583-1610
 E-mail: tlv@tlvengineering.com
 For Technical Service 1-800 "TLV TRAP"



Manufacturer
TLV CO., LTD.
 Kakogawa, Japan
 is approved by LRQA Ltd. to ISO 9001/14001

ISO 9001/ISO 14001

