



STEAM & CONDENSATE MANIFOLD

MODEL M4/M8/M12

RUGGED MANIFOLD WITH BUILT-IN BELLOWS SEALED VALVES

Benefits

Forged steel manifolds for steam distribution and condensate recovery on tracing and other applications.

1. Rugged and versatile design minimizes installation area and easily adapts to plant requirements.
2. Each line has a built-in bellows sealed valve, minimizing installation space.
3. Good seal with stellite hardened surfaces on valve plugs and valve seats.
4. Durable stainless steel bellows eliminate gland leakage.
5. Built-in blowdown and drain connections.
6. Complete condensate manifold packages are available, incorporating shutoff valves and steam traps.

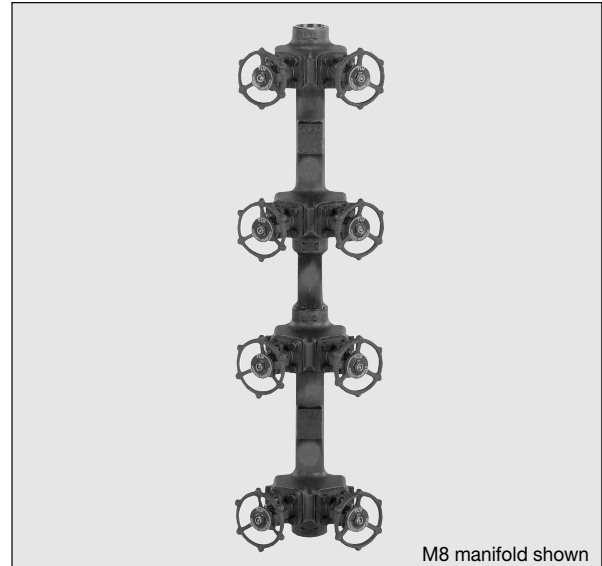

M8 manifold shown

Specifications

Model		M4		M8		M12	
Steam Outlet* / Condensate Inlet**	No. of Connections	4		8		12	
	Connection***	Screwed	Socket Weld	Screwed	Socket Weld	Screwed	Socket Weld
	Size (in)	1/2, 3/4	1/2, 3/4	1/2, 3/4	1/2, 3/4	1/2, 3/4	1/2, 3/4
Steam Inlet* / Condensate Outlet**	Connection***	Socket Weld					
	Size (in)	1 1/2					
Drain* / Blowdown**	Connection***	Socket Weld					
	Size (in)	1 1/2					
Maximum Operating Pressure (psig) PMO		710					
Maximum Operating Temperature (°F) TMO		752					
Maximum Allowable Pressure (psig) PMA		825					
Maximum Allowable Temperature (°F) TMA		800					

* When used as a steam manifold ** When used as a condensate manifold

Connections and sizes in bold are standard

*** Flanged connections available as an option



To avoid abnormal operation, accidents or serious injury, DO NOT use this product outside of the specification range. Local regulations may restrict the use of this product to below the conditions quoted.

No.	Description	Material	ASTM/AISI*	JIS
①	Body	Carbon Steel	A105	—
② ^R	Valve Bonnet	Carbon Steel	A105	—
③ ^R	Valve Plug	Stainless Steel + Stellite	A276-304	—
④	Valve Seat	Stainless Steel + Stellite	A276-410	—
⑤ ^R	Valve Stem	Stainless Steel	A276-410	—
⑥ ^R	Bellows	Stainless Steel	AISI316L	SUS316L
⑦ ^R	Bellow Flange	Stainless Steel	A276-316L	—
⑧ ^R	Lower Bonnet Gasket	Graphite/Stainless Steel	-/AISI316	-/SUS316
⑨ ^R	Upper Bonnet Gasket	Graphite/Stainless Steel	-/AISI304	-/SUS304
⑩ ^R	Bonnet Bolt	Alloy Steel	A193 Gr.B7	—
⑪ ^R	Gland Packing	Graphite	—	—
⑫ ^R	Gland Bushing	Stainless Steel	A276-410	—
⑬ ^R	Gland Flange	Carbon Steel	A105	—
⑭ ^R	Gland Eye Bolt	Alloy Steel	A193 Gr.B7	—
⑮ ^R	Gland Nut	Carbon Steel	A194 Gr.2H	—
⑯ ^R	Handwheel	Ductile Cast Iron	A536	FCD450
⑰ ^R	Handwheel Nut	Carbon Steel	AISI1025	S25C
⑱	Nameplate	Stainless Steel	AISI304	SUS304

* Equivalent

Replacement kits available: (R) repair parts

Note: The repair kit contains parts for repairing only one valve unit. Repair kits equal to the number of valve units needing repair are required.

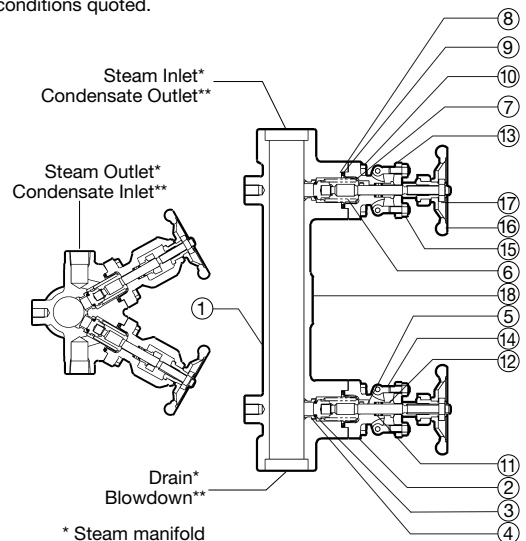

* Steam manifold
** Condensate manifold

Dimensions

● **M4 / M8 / M12**

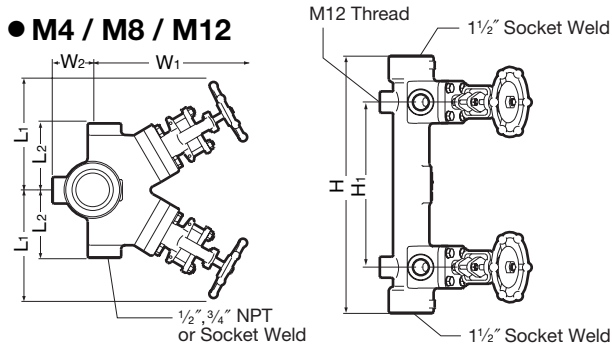

M4 manifold shown

Optional Siphon Tube for Condensate Manifolds

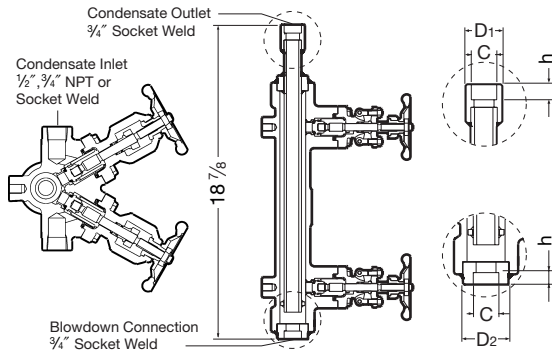

M4 shown; optional siphon tubes are also available for M8 and M12

M4 / M8 / M12

Model	L1*	L2	H	H1	W1*	W2	Weight (lb)
M4			15 3/8				37
M8	5 5/16	3 1/8	35**	9 7/8	7 1/4	1 7/8	74
M12			54 3/4**				114

* At full open position ** Approximate

Socket Weld Connections*

Size	φD	φC	h
1/2	1 7/16	0.855	1/2
3/4		1.065	
1 1/2	2 1/2	1.915	

* ASME B16,11-2005

Siphon Tube Socket Weld*

Size	φD1	φD2	φC	h
3/4	1 7/16	1 13/16	1 1/16	1/2

* ASME B16,11-2005

Note: Condensate inlet connections for manifolds with siphon tubes have the same dimensions as for standard M4/M8/M12.

Optional Condensate Manifold Packages

Packages are available for the M4, M8 and M12 manifolds (pictures show M8 manifold packages).

Package	Components
① With V1 Trap Stations Trap station model: Shutoff valve type: Steam trap unit: (QuickTrap*)	Right flow: V1-RB; Left flow: V1-LB Bellows-sealed valve (built-in) Free Float: S3/S5/S5H Thermodyne: P46UC Thermostatic: L21/L32/X1
② With Steam Traps & Valves Shutoff valve type: Steam trap:	Bellows-sealed valve** Free Float: SS1** Temperature Control: LEX3-TZ** (with built-in scale removal feature)

* For more information, see the **QuickTrap** specifications data sheet for the steam trap employing the desired trap unit (trap unit - **QuickTrap** data sheet): S3 - FS3/FS5; S5 - FS3/FS5; S5H - FS5H; P46UC - FP46UC; L21 - FL21/FL32; L32 - FL21/FL32; X1 - FX1

** Other steam traps and valve types are available

Note: The operating pressure and temperature ranges of the manifold package are limited to those of the steam trap or valves used. See the specifications data sheet for the steam trap or valve, or contact TLV for more details.

① With V1 Trap Stations ② With Steam Traps & Valves

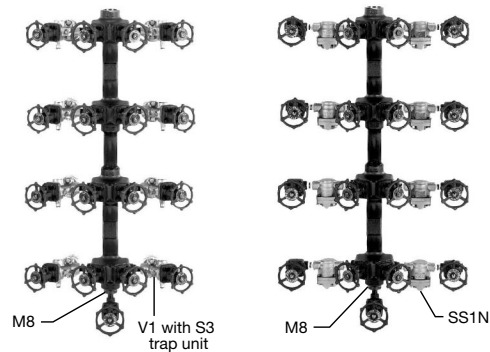

DO NOT DISASSEMBLE OR REMOVE THIS PRODUCT WHILE IT IS UNDER PRESSURE. Allow internal pressure of this product to equal atmospheric pressure and its surface to cool to room temperature before disassembling or removing. Failure to do so could cause burns or other injury. READ INSTRUCTION MANUAL CAREFULLY.

TLV CORPORATION

13901 South Lakes Drive, Charlotte, NC 28273-6790
Phone: 704-597-9070 Fax: 704-583-1610
E-mail: tlv@tlvengineering.com
For Technical Service 1-800 "TLV TRAP"



Manufacturer
TLV CO., LTD.
Kakogawa, Japan
is approved by LRQA Ltd. to ISO 9001/14001

