



Air Conditioning & Heating

GMS8/GDS8/GHS8

HEATING INPUT : 40,000–140,000 BTU/H

*SINGLE-STAGE, MULTI-SPEED,
MULTI-POSITION GAS FURNACE
80% AFUE*

Contents

Nomenclature.....	2
Product Specifications.....	3
Dimensions	5
Airflow Data	8
Wiring Diagrams	11
Accessories	12
Minimum Filter Sizes	12



Standard Features

- Heavy-duty aluminized-steel, dual-diameter tubular heat exchanger
- Single-stage gas valve
- Durable Hot-surface igniter
- Quiet, single-speed draft induced
- Self-diagnostic control board
- Color-coded low-voltage terminals
- Multi-speed blower motor
- California Low NOx emissions models available
- GHS8: High static airflow capability

Cabinet Features

- Installation:
 - GMS8/GHS8 -upflow, horizontal left or right
 - GDS8- Dedicated downflow
- Convenient left or right connection for gas and electrical service
- Heavy-gauge steel cabinet with durable baked-enamel finish
- Foil faced insulated heat exchanger



* Complete warranty details available from your local dealer or at www.goodmanmfg.com. To receive the Lifetime Heat Exchanger Limited Warranty (good for as long as you own your home) and 10-Year Parts Limited Warranty, online registration must be completed within 60 days of installation. Online registration is not required in California or Québec.

	GMS8 0403A*B	GMS8 0603A*B	GMS8 0604B*B	GMS8 0804B*B	GMS8 0805C*B	GMS8 1005C*B	GMS8 1205D*B	GMS8 1405DNC
HEATING CAPACITY								
Input	40,000	60,000	60,000	80,000	80,000	100,000	120,000	140,000
Natural Gas Output	32,000	48,000	48,000	64,000	64,000	80,000	96,000	112,000
LP Gas Output	32,000	48,000	48,000	64,000	64,000	80,000	96,000	96,000
AFUE ¹	80	80	80	80	80	80	80	80
Available AC @ 0.5" ESP	3	3	4	4	5	5	5	5
Temperature Rise Range (°F)	25 - 55	20 - 50	20 - 50	35 - 65	35 - 65	35 - 65	40 - 70	40 - 70
CIRCULATOR BLOWER								
Size (D x W)	10" x 6"	10" x 6"	10" x 8"	10" x 8"	10" x 10"	10" x 10"	11" x 10"	11" x 10"
Horsepower @1075 RPM	⅓	⅓	½	½	½	½	¾	¾
Speed	4	4	4	4	4	4	4	4
Vent Diameter ²	4"	4"	4"	4"	4"	4"	4"	4"
No. of Burners	2	3	3	4	4	5	6	6
ELECTRICAL DATA								
Min. Circuit Ampacity ³	4.8	4.8	8.8	8.8	8.8	8.8	14.7	14.7
Max. Overcurrent Device (amps) ⁴	15	15	15	15	15	15	15	15
SHIP WEIGHT (LBS)								
	84	88	98	106	114	118	130	130

All models available in California Low NOx-compliant versions (except GMS81405D*C*)

¹ DOE AFUE based upon Isolated Combustion System (ICS)

² Vent and combustion air diameters may vary depending upon vent length. Refer to the latest editions of the National Fuel Gas Code NFPA 54/ANSI Z223.1 (in the USA) and the Canada National Standard of Canada, CAN/CSA B149.1 and CAN/CSA B142.2 (in Canada).

³ Minimum Circuit Ampacity = (1.25 x Circulator Blower Amps) + ID Blower amps. Wire size should be determined in accordance with National Electrical Codes. Extensive wire runs will require larger wire sizes.

⁴ Maximum Overcurrent Protection Device refers to maximum recommended fuse or circuit breaker size. May use fuses or HACR-type circuit breakers of the same size as noted.

NOTES

- All furnaces are manufactured for use on 115 VAC, 60 Hz, single-phase electrical supply.
- Gas Service Connection ½" FPT
- Important: Size fuses and wires properly and make electrical connections in accordance with the National Electrical Code and/or all existing local codes.

	GDS8 0403A*B	GDS8 0603A*B	GDS8 0804B*B	GDS8 1005C*B	GHS8 0403A*B	GHS8 0604B*B	GHS8 0805C*B
HEATING CAPACITY							
Input	40,000	60,000	80,000	100,000	40,000	60,000	80,000
Natural Gas Output	32,000	48,000	64,000	80,000	32,000	48,000	64,000
LP Gas Output	32,000	48,000	64,000	80,000	32,000	48,000	64,000
AFUE ¹	80	80	80	80	80	80	80
Available AC @ 0.5" ESP	3	3	4	5	3	4	5
Temperature Rise Range (°F)	25 - 55	30-60	35-65	40 - 70	20 - 50	20 - 50	35 - 65
CIRCULATOR BLOWER							
Size (D x W)	10" x 6"	10" x 6"	10" x 8"	10" x 10"	11" x 6"	11" x 8"	11" x 10"
Horsepower @1075 RPM	1/3	1/3	1/2	3/4	1/2	3/4	3/4
Speed	4	4	4	4	4	4	4
Vent Diameter ²	4"	4"	4"	4"	4"	4"	4"
No. of Burners	2	3	4	5	2	3	4
ELECTRICAL DATA							
Min. Circuit Ampacity ³	4.8	4.8	8.8	10.5	10.5	13.7	13.7
Max. Overcurrent Device (amps) ⁴	15	15	15	15	15	15	15
SHIP WEIGHT (LBS)							
	88	92	105	113	90	102	117

¹ DOE AFUE based upon Isolated Combustion System (ICS)

² Vent and combustion air diameters may vary depending upon vent length. Refer to the latest editions of the National Fuel Gas Code NFPA 54/ANSI Z223.1 (in the USA) and the Canada National Standard of Canada, CAN/CSA B149.1 and CAN/CSA B142.2 (in Canada).

³ Minimum Circuit Ampacity = (1.25 x Circulator Blower Amps) + ID Blower amps. Wire size should be determined in accordance with National Electrical Codes. Extensive wire runs will require larger wire sizes.

⁴ Maximum Overcurrent Protection Device refers to maximum recommended fuse or circuit breaker size. May use fuses or HACR-type circuit breakers of the same size as noted.

NOTES

- All furnaces are manufactured for use on 115 VAC, 60 Hz, single-phase electrical supply.
- Gas Service Connection ½" FPT
- Important: Size fuses and wires properly and make electrical connections in accordance with the National Electrical Code and/or all existing local codes.

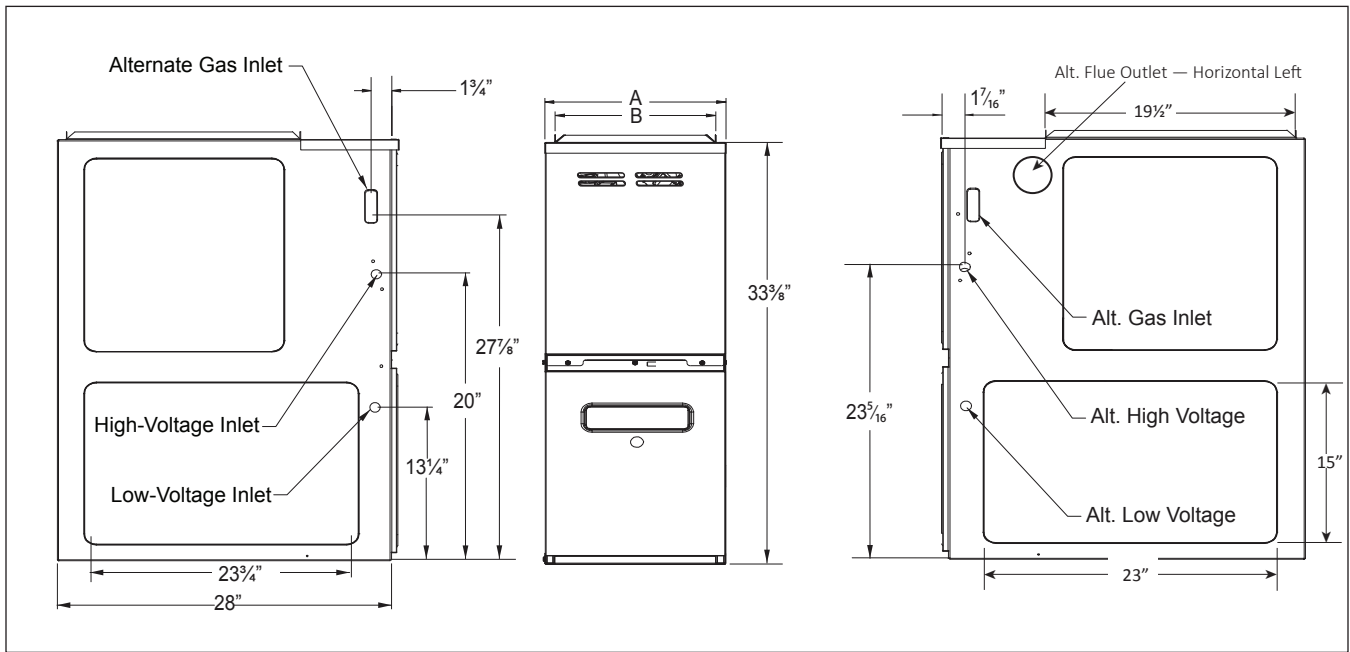

MODEL	A	B
GMS80403A*B	14"	12 1/2"
GMS80603A*B	14"	12 1/2"
GMS80604B*B	17 1/2"	16"
GMS80804B*B	17 1/2"	16"

MODEL	A	B
GMS80805C*B	21"	19 1/2"
GMS81005C*B	21"	19 1/2"
GMS81205D*B	24 1/2"	23"
GMS81405DNC*	24 1/2"	23"

NOTES

- Line voltage wiring can enter through the right or left side of furnace. Low-voltage wiring can enter through the right or left side of furnace.
- Conversion kits for high-altitude (4500+ ft) natural gas operation are available. Contact your Goodman distributor or dealer for details.

MINIMUM CLEARANCES TO COMBUSTIBLE MATERIALS

SIDES	REAR	FRONT ¹	VENT ²		TOP
			SW	B	
1"	0"	3"	6"	1"	1"

¹ 24" clearance for serviceability recommended.

² Single Wall Vent (SW) to be used only as a connector. Refer to the latest editions of the National Fuel Gas Code NFPA 54/ ANSI Z223.1 (in the USA) and the Canada National Standard of Canada, CAN/CSA B149.1 and CAN/CSA B142.2 (in Canada).

Note: GMS8 approved for line contact in the horizontal position.

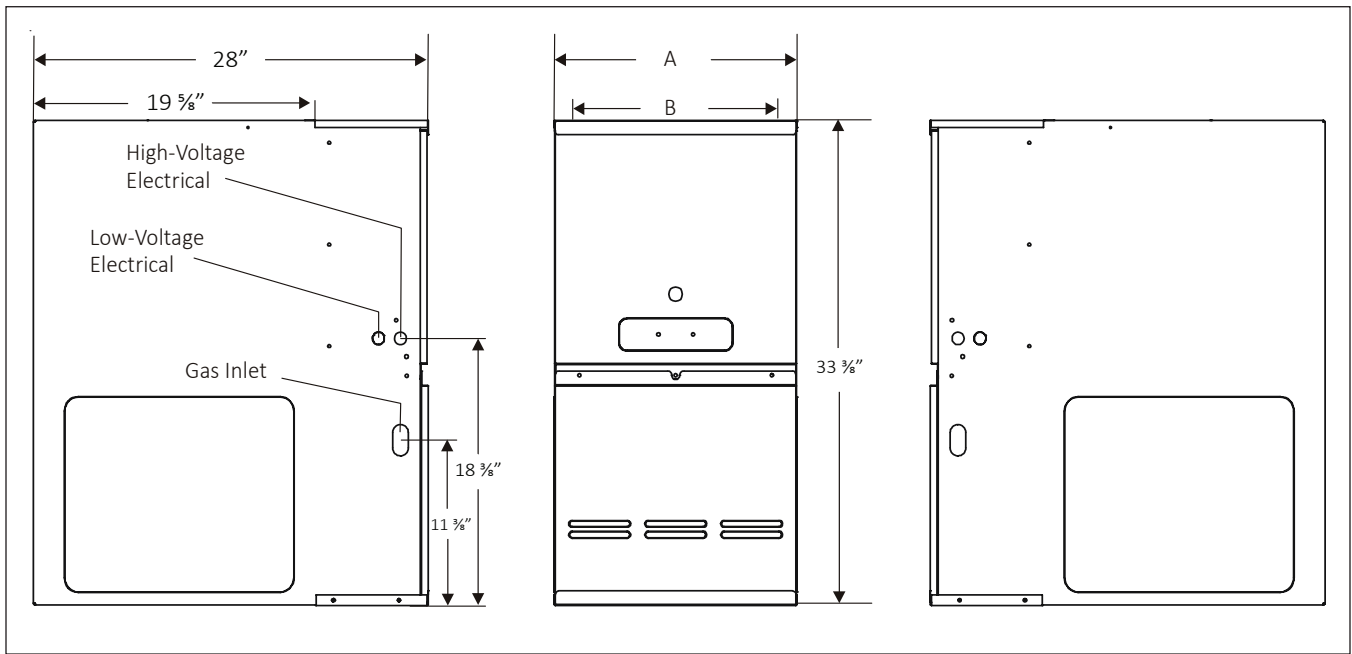

MODEL	A	B	NON-COMBUSTIBLE FLOOR BASE
GDS80403A*B	14"	12½"	SBT14
GDS80603A*B	14"	12½"	SBT14
GDS80804B*B	17½"	16"	SBT17
GDS81005C*B	21"	19½"	SBT21

NOTES

- Line voltage wiring can enter through the right or left side of furnace. Low-voltage wiring can enter through the right or left side of furnace.
- Conversion kits for high-altitude (4500+ ft) natural gas operation are available. Contact your Goodman distributor or dealer for details.

MINIMUM CLEARANCES TO COMBUSTIBLE MATERIALS

SIDES	REAR	FRONT ¹	VENT ²		TOP
			SW	B	
1"	0"	3"	6"	1"	1"

¹ 24" clearance for serviceability recommended.

² Single Wall Vent (SW) to be used only as a connector. Refer to the latest editions of the National Fuel Gas Code NFPA 54/ ANSI Z223.1 (in the USA) and the Canada National Standard of Canada, CAN/CSA B149.1 and CAN/CSA B142.2 (in Canada).

Note: GMS8 approved for line contact in the horizontal position.

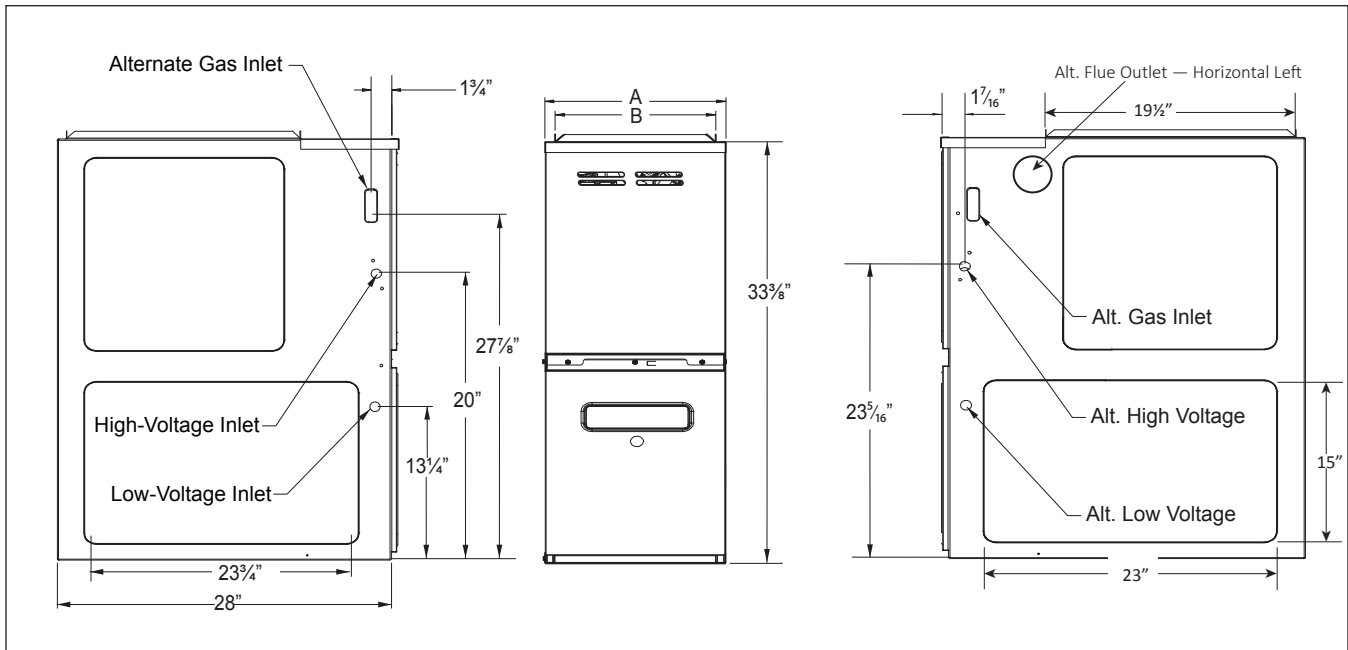

MODEL	A	B
GHS80403AXB*	14"	12 1/2"
GHS80604BXB*	17 1/2"	16"
GHS80805CXB*	21"	19 1/2"

NOTES

- Line voltage wiring can enter through the right or left side of furnace. Low-voltage wiring can enter through the right or left side of furnace.
- Conversion kits for high-altitude (4500+ ft) natural gas operation are available. Contact your Goodman distributor or dealer for details.

MINIMUM CLEARANCES TO COMBUSTIBLE MATERIALS

SIDES	REAR	FRONT ¹	VENT ²		TOP
			SW	B	
1"	0"	3"	6"	1"	1"

¹ 24" clearance for serviceability recommended.

² Single Wall Vent (SW) to be used only as a connector. Refer to the latest editions of the National Fuel Gas Code NFPA 54/ ANSI Z223.1 (in the USA) and the Canada National Standard of Canada, CAN/CSA B149.1 and CAN/CSA B142.2 (in Canada).

Note: GMS8 approved for line contact in the horizontal position.

