

DUNHAM-BUSH®

FORM NO: MS0216A

Products That Perform...By People Who Care

HORIZONTAL WATER-COOLED SINGLE PACKAGED AIR CONDITIONER

60 Hz

Features:

- Compact Design
- Reliable Performance
- Application Flexibility
- Wide Capacity Range

6WCP-CH SERIES
6WCPS-CH SERIES

Cooling Capacity:
18 - 285 MBH

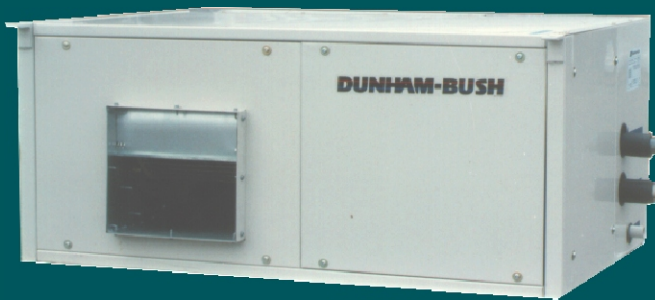

WATER-COOLED PACKAGE UNITS

GENERAL DESCRIPTION

The compact, rugged and reliable 6WCP/6WCPS-CH, water-cooled, horizontal single packaged unit, is designed to meet the owners, consultants and contractors requirement of efficient, quiet and dependable performance. The wide range of cooling capacity satisfy most requirement for offices, industrial buildings, supermarkets, shops etc. These units are factory assembled, leak tested, evacuated, dehydrated, precharged with correct amount of refrigerant, tested run in factory and ready for installation.

Reciprocating Compressor

(6WCP-CH Series)

Hermetic reciprocating, refrigerant gas cooled high torque induction motor, quiet running with internal suspension system to eliminate vibration and internal inherent line break motor protection. Crankcase heater to prevent liquid migration during off cycle and eases start-up (for 3 phase unit only).

Scroll Compressor(s)

(6WCPS-CH Series)

Reliability

- * No contact scroll design that minimizes friction, increases volumetric efficiency and reduces vibration, thus longer service life.
- * Suction gas cooled motor.

Low Power Consumption:

- * High EER.
- * No crankcase heater required.



Cleanable Shell and Tube Condenser

- * Multiple 3/4" O.D. copper finned tubes with 25 to 30% more surface area ensure better heat transfer.
- * Integral subcooling circuit to maximize efficiency.
- * Provided with fusible plug for safety purpose.

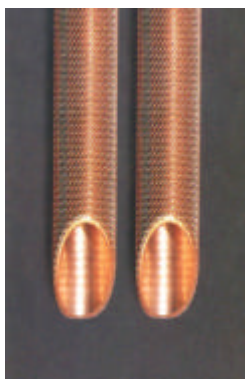

- * Leak and pressure tested to 450 psig.

Fully Leak Tested Refrigerant Circuit

- * Leak and pressure tested at 450 psig.
- * Pressure ports are provided on the discharge, liquid and suction line.
- * Evacuated, dehydrated and charged with refrigerant.

Safety Components

High pressure and low pressure cutouts for model WCP-46Ch and above, to guard against compressor damage due to high discharged head pressure and system leakage respectively.

Efficient Evaporator Coil

- * For model 81CH and above, independent thermal expansion valve with external equalizer for better refrigerant control and wider load condition.
- * Leak and pressure tested to 450 psig
- * Evacuated, dehydrated and charged with refrigerant.

Drive Package and Blowers

(6WCP 68CH - 6WCPS 285CH)

- * Belt driven drive package offers flexibility on various air flow rate and various static pressure applications.
- * Single large diameter double inlet double width blowers reduce the noise level and eliminates the need for common transition and eliminates air unbalance.

Casing

- * Constructed of electro galvanized steel sheet and insulated with 1/2" thick x 1 1/2 lb per cu.ft linacoustic fiberglass.
- * Aesthetically coated with powder paint to provide excellent finish, weatherability and corrosion resistance.
- * Removable panels on the left and right hand side of the unit to provide access to critical parts and components.

Filters

Side loading 1" thick filters - from both sides-thus eliminates unnecessary duct opening at site.

WATER-COOLED PACKAGE UNITS

Optional Accessories Features

- * Factory wired starters
 - DOL for compressors and fan motors.
 - Auto-transformer for compressors.
- * Suction stop valve(s), discharge stop valve(s) and liquid stop valve(s).
- * External spring vibration isolators for blower fan and drive assembly.
- * Thermostat.
- * Hydrophilic aluminum fins, copper fins or tinned coated copper fins for better corrosion resistance.
- * Hot gas by pass for low load conditions.
- * Decorative discharge plenum.
- * Hot water heating coils.
- * Electric heaters.
- * R407C refrigerant instead of R22.

CONDENSER WATER PRESSURE DROP- FT. W.G.

6WCP 18CH		6WCP 24CH		6WCP 28CH		6WCP 32CH		6WCP 35CH		6WCP 46CH		6WCP 56CH		6WCPS 68CH		6WCPS 81CH			
GPM	FT	GPM	FT	GPM	FT	GPM	FT	GPM	FT	GPM	FT	GPM	FT	GPM	FT	GPM	FT	GPM	FT
3.0	1.4	3.5	1.7	5.0	1.2	6.0	0.6	6.0	0.6	7.0	0.9	10.0	1.2	10.0	1.0	10.0	0.9		
4.0	1.7	4.5	1.8	6.5	1.7	7.5	1.2	7.5	1.2	10.0	1.4	13.0	1.6	15.0	1.9	15.0	1.7		
5.0	2.0	5.5	2.0	8.0	1.8	9.0	1.7	9.0	1.7	13.0	1.8	16.0	2.8	20.0	3.6	20.0	3.4		
6.0	2.4	6.5	2.9	9.5	1.9	10.5	2.2	10.5	2.2	16.0	3.1	20.0	4.4	25.0	5.7	25.0	5.4		

6WCPS 95CH		6WCPS 108CH		6WCPS 145CH		6WCPS 160CH		6WCPS 190CH		6WCPS 220CH		6WCPS 250CH			6WCPS 285CH			
GPM	FT	GPM	FT	GPM	FT	GPM	FT	GPM	FT	GPM	FT	GPM	FT	COND 1		COND 2	COND 1 & COND 2	
														GPM	FT	FT	GPM	FT
15.0	1.5	20.0	1.7	25.0	1.3	25.0	1.0	30.0	1.2	30.0	0.9	25.0	1.3	5.1	25.0	1.3		
20.0	3.1	25.0	2.6	30.0	1.7	35.0	2.0	40.0	2.5	40.0	2.2	35.0	1.7	6.8	30.0	1.7		
25.0	5.1	30.0	3.5	35.0	2.4	40.0	3.2	50.0	4.5	50.0	4.5	40.0	2.4	8.3	35.0	2.4		
30.0	8.0	35.0	4.4	40.0	3.7	45.0	4.5	60.0	5.3	60.0	5.4	45.0	3.7	11.0	40.0	3.7		

CONVERSION FACTORS: FT. W.G. = PSI x 2.31 = BAR x 33.5 = KPA x 0.33
 USGPM = L / MIN. x 0.26

NOMENCLATURE

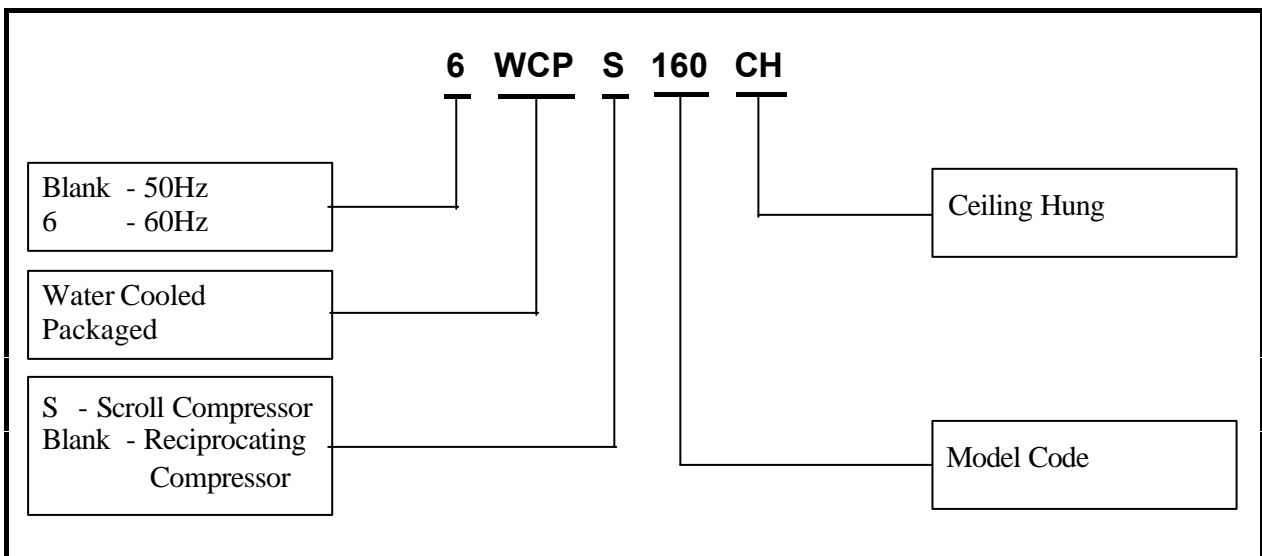

SYSTEM COOLING CAPACITY

PERFORMANCE DATA

MODEL	STD CAPACITY MBH	AIR ON EVAP.		LEAVING CONDENSER WATER TEMPERATURE - °F								
		CFM	WB TEMP. °F	80			95			110		
				TOTAL MBH ¹	SENS MBH ²	KW ³	TOTAL MBH ¹	SENS MBH ²	KW ³	TOTAL MBH ¹	SENS MBH ²	KW ³
6WCP 18CH	18	650	72	20.26	10.77	1.24	19.09	10.14	1.33	17.23	9.17	1.39
			67	19.31	14.31	1.18	18.00	13.34	1.30	17.06	12.66	1.36
			62	17.63	17.63	1.18	16.29	16.29	1.27	15.57	15.57	1.33
			57	15.57	15.57	1.15	14.40	14.40	1.27	13.69	13.69	1.33
6WCP 24CH	24	800	72	27.01	14.36	1.72	25.45	13.52	1.84	22.97	12.23	1.92
			67	25.75	19.09	1.64	24.00	17.79	1.80	22.74	16.88	1.88
			62	23.50	23.50	1.64	21.71	21.71	1.76	20.76	20.76	1.84
			57	20.76	20.76	1.60	19.20	19.20	1.76	18.25	18.25	1.84
6WCP 28CH	28	1000	72	31.51	16.76	2.00	29.69	15.78	2.15	26.80	14.27	2.24
			67	30.04	22.27	1.91	28.00	20.76	2.10	26.53	19.69	2.20
			62	27.42	27.42	1.91	25.33	25.33	2.05	24.22	24.22	2.15
			57	24.22	24.22	1.86	22.40	22.40	2.05	21.29	21.29	2.15
6WCP 32CH	32	1250	72	36.01	19.15	2.29	33.93	18.03	2.45	30.63	16.30	2.56
			67	34.34	25.45	2.18	32.00	23.72	2.40	30.32	22.50	2.51
			62	31.34	31.34	2.18	28.95	28.95	2.35	27.68	27.68	2.45
			57	27.68	27.68	2.13	25.60	25.60	2.35	24.33	24.30	2.45
6WCP 35CH	35	1500	72	39.39	20.94	2.48	37.11	19.72	2.66	33.50	17.83	2.78
			67	37.56	27.83	2.36	35.00	25.94	2.60	33.17	24.61	2.72
			62	34.28	34.28	2.36	31.67	31.67	2.54	30.28	30.28	2.66
			57	30.28	30.28	2.30	28.00	28.00	2.54	26.61	26.61	2.66
6WCP 46CH	46	1750	72	51.77	27.53	3.25	48.77	25.92	3.48	44.03	23.44	3.63
			67	49.36	36.58	3.09	46.00	34.10	3.40	43.59	32.35	3.55
			62	45.05	45.05	3.09	41.62	41.62	3.32	39.79	39.79	3.48
			57	39.79	39.76	3.01	36.80	36.80	3.32	34.97	34.97	3.48
6WCP 56CH	56	1900	72	63.02	33.51	4.01	59.38	31.56	4.30	53.60	28.53	4.49
			67	60.09	44.53	3.82	56.00	41.51	4.20	53.07	39.38	4.39
			62	54.84	54.84	3.82	50.67	50.67	4.10	48.44	48.44	4.30
			57	48.44	48.44	3.72	44.80	44.80	4.10	42.58	42.58	4.30
6WCP 68CH	68	2100	72	76.56	40.71	3.25	72.14	38.33	3.49	65.12	34.67	3.64
			67	73.00	54.10	3.10	68.00	50.43	3.41	64.48	47.84	3.56
			62	66.63	66.63	3.10	61.56	61.56	3.33	58.86	58.86	3.49
			57	58.86	58.86	3.02	54.43	54.43	3.33	51.73	51.73	3.49
6WCPS 81CH	81	2500	72	91.10	45.50	3.78	85.86	43.32	4.05	77.50	41.13	4.22
			67	86.88	59.10	3.60	81.00	58.40	4.68	76.74	54.64	4.14
			62	79.29	73.17	3.60	73.26	70.06	3.87	70.05	69.02	4.05
			57	70.05	70.05	3.50	64.78	64.78	3.87	61.57	61.57	4.05
6WCPS 95CH	95	3400	72	106.96	56.88	4.63	100.77	53.55	4.96	90.96	48.43	5.18
			67	101.98	75.58	4.41	95.00	70.45	4.85	90.07	66.83	5.07
			62	93.08	93.08	4.41	85.99	85.99	4.74	82.22	82.22	4.96
			57	82.22	82.22	4.30	76.03	76.03	4.74	72.26	72.26	4.96
6WCPS 108CH	108	3500	72	121.57	64.81	5.11	114.50	61.08	5.48	108.02	57.64	5.71
			67	115.88	86.22	4.96	108.00	80.43	5.41	102.42	76.20	5.71
			62	105.86	105.07	4.89	99.08	98.40	5.34	93.49	93.49	5.56
			57	93.49	93.49	4.82	86.61	86.61	5.26	82.10	82.10	5.56
6WCPS 145CH	145	4200	72	163.20	76.90	7.10	153.70	72.40	7.60	145.00	68.30	8.00
			67	155.60	101.50	6.70	145.00	94.60	7.40	137.30	89.60	7.70
			62	142.00	123.70	6.70	132.90	115.80	7.30	125.40	110.20	7.60
			57	125.40	110.20	6.60	116.30	102.20	7.30	110.20	96.80	7.60
6WCPS 160CH	160	4400	72	179.90	102.69	7.96	169.53	96.73	8.51	159.94	91.11	8.83
			67	171.63	139.09	7.72	160.00	129.60	8.35	151.66	122.87	8.75
			62	156.63	156.63	7.64	146.70	146.70	8.20	138.32	138.32	8.59
			57	138.32	138.32	7.41	127.95	127.95	8.12	122.65	122.65	8.51
6WCPS 190CH	190	5400	72	213.67	102.99	9.15	201.37	107.16	9.72	189.95	101.13	10.13
			67	203.79	150.10	8.74	190.00	139.89	9.56	180.07	132.64	10.05
			62	186.00	182.60	8.66	174.14	170.96	9.40	164.26	164.26	9.80
			57	163.60	163.60	8.50	152.29	152.29	9.31	144.39	144.39	9.80
6WCPS 220CH	220	6200	72	248.80	144.60	10.47	234.50	136.30	11.07	220.00	127.80	11.75
			67	233.40	192.90	10.39	220.00	181.80	10.99	206.60	170.70	11.67
			62	215.60	215.60	10.24	204.40	204.40	10.92	178.00	178.00	11.60
			57	195.60	195.60	10.09	173.40	173.40	10.84	170.00	170.00	11.52
6WCPS 250CH	250	7400	72	281.16	148.47	11.66	264.89	139.85	12.49	249.90	131.91	13.03
			67	265.19	194.73	11.32	250.00	183.46	12.28	236.87	173.95	12.90
			62	244.61	230.20	11.18	228.34	228.34	12.07	216.19	216.19	12.62
			57	222.07	222.07	10.91	200.41	200.41	11.94	189.92	189.92	12.55
6WCPS 285CH	285	8600	72	322.52	162.00	13.73	303.75	152.56	14.62	285.07	143.22	15.50
			67	302.37	207.81	13.66	285.00	195.91	14.48	267.77	184.02	15.44
			62	279.27	250.27	13.46	264.92	237.39	14.41	247.62	221.86	15.30
			57	253.42	253.42	13.32	238.97	238.97	14.27	221.67	221.67	15.23

- NOTES: 1.) RATINGS ARE GROSS CAPACITIES - FOR NET CAPACITIES, DEDUCT EVAPORATOR BLOWER MOTOR HEAT.
 (MBH = 1000 x BTU / HR)
 2.) AT 80°F (26.6°C) AIR ON EVAPORATOR.
 3.) COMPRESSOR MOTOR POWER INPUT AT RATED VOLTAGE (KW)
 4.) FOR MODEL 6WCP 18-CH TO 56-CH, THE PERFORMANCE IS BASE ON NOMINAL CFM HIGH SPEED.

BLOWER PERFORMANCE

Available External Static Pressure - IWG - For Accessories And Duct System Static Resistance (Allowance Made For Wet Coil And Filters)

a.) Model 6WCP 18CH to 56CH (Direct Drive)

6WCP 18CH		6WCP 24CH		6WCP 28CH		6WCP 32CH		6WCP 35CH		6WCP 46CH		6WCP 56CH	
DDM 7/7		DDM 7/9		DDM 7/9		DDM 9/7		DDM 9/7		DDM 9/9		DDM 9/9	
CFM	ESP	CFM	ESP	CFM	ESP	CFM	ESP	CFM	ESP	CFM	ESP	CFM	ESP
600	0.66	800	0.58	800	0.62	1000	1.33	1100	1.01	1500	1.42	1500	1.35
650	0.58	900	0.55	900	0.59	1100	1.01	1200	0.78	1600	1.32	1600	1.25
700	0.48	1000	0.52	1000	0.58	1200	0.78	1300	0.51	1700	1.17	1700	1.09
750	0.27	1100	0.45	1100	0.51	1300	0.51	1400	0.08	1800	1.01	1800	0.92

NOTE: DATA IS BASE ON HIGH SPEED.

b.) Model 6WCP 68CH to 6WCPS 285CH (Belt Drive)

RPM	CFM										FAN MODEL
	ESP	BHP	ESP	BHP	ESP	BHP	ESP	BHP	ESP	BHP	
6WCP 68CH											
900 1000 1100 1200	1700		1900		2100		2300		2500		ONE AT 10/10 SC
	0.45	0.44	0.39	0.50	0.29	0.56	0.19	0.63	0.06	0.70	
	0.67	0.53	0.62	0.60	0.55	0.67	0.47	0.76	0.35	0.84	
	0.90	0.63	0.87	0.71	0.81	0.80	0.75	0.90	0.65	0.99	
1.14	0.74	1.12	0.84	1.08	0.94	1.03	1.05	0.95	1.15		
6WCPS 81CH											
1100 1200 1300 1400	2000		2250		2500		2750		3000		ONE AT 10/10 SC
	0.77	0.76	0.69	0.87	0.56	0.99	0.38	1.12	0.16	1.24	
	1.04	0.89	0.97	1.02	0.86	1.15	0.70	1.29	0.51	1.45	
	1.31	1.03	1.26	1.18	1.18	1.34	1.04	1.50	0.87	1.67	
1.59	1.19	1.56	1.35	1.49	1.53	1.38	1.71	1.23	1.90		
6WCPS 95CH											
700 800 900 1000	2800		3100		3400		3700		4200		ONE AT 12/12 SC
	0.23	0.67	0.16	0.79	0.06	0.91	-	-	-	-	
	0.48	0.81	0.42	0.95	0.35	1.10	0.26	1.25	0.04	1.53	
	0.74	0.97	0.70	1.13	0.64	1.29	0.57	1.48	0.39	1.80	
1.03	1.15	0.99	1.32	0.95	1.51	0.90	1.72	0.75	2.10		
6WCPS 108CH											
800 900 1000 1100	3000		3400		3800		4200		4600		ONE AT 12/12 SC
	0.50	0.90	0.41	1.10	0.29	1.31	0.14	1.53	-	-	
	0.77	1.07	0.70	1.29	0.61	1.54	0.49	1.80	0.32	2.09	
	1.06	1.26	1.01	1.51	0.94	1.80	0.85	2.10	0.71	2.42	
1.37	1.47	1.34	1.76	1.28	2.06	1.21	2.40	1.10	2.77		
6WCPS 145CH											
850 900 950 1000	3300		3800		4200		4600		5000		ONE AT 12/12 SC
	0.56	1.14	0.43	1.42	0.27	1.67	0.08	1.93	-	-	
	0.70	1.24	0.59	1.54	0.44	1.80	0.27	2.09	0.06	2.38	
	0.85	1.34	0.75	1.66	0.62	1.95	0.47	2.26	0.27	2.57	
1.00	1.45	0.92	1.80	0.80	2.10	0.66	2.42	0.48	2.76		
6WCPS 160CH											
900 950 1000 1050	3400		3900		4400		4900		5400		ONE AT 12/12 SC
	0.68	1.29	0.55	1.60	0.36	1.94	0.12	2.30	-	-	
	0.84	1.41	0.72	1.74	0.55	2.10	0.33	2.49	0.02	2.90	
	0.99	1.51	0.89	1.87	0.73	2.26	0.54	2.68	0.25	3.12	
1.15	1.63	1.06	2.00	0.92	2.42	0.74	2.87	0.48	3.35		
6WCPS 190CH											
800 850 950 1050	3500		4200		4900		5600		6000		ONE AT 15/15 SC
	0.85	1.37	0.77	1.68	0.64	2.03	0.46	2.42	0.34	2.69	
	1.01	1.53	0.95	1.88	0.84	2.26	0.67	2.68	0.55	2.94	
	1.37	1.90	1.33	2.31	1.24	2.75	1.10	3.23	1.01	3.54	
1.76	2.31	1.74	2.80	1.68	3.32	1.57	3.87	1.48	4.20		
6WCPS 220CH											
800 850 900 950	4900		5300		5700		6100		6500		ONE AT 18/18 SC
	1.25	2.37	1.21	2.56	1.18	2.77	1.14	2.99	1.08	3.22	
	1.48	2.68	1.45	2.90	1.41	3.11	1.38	3.35	1.32	3.60	
	1.73	3.04	1.69	3.25	1.66	3.49	1.63	3.74	1.57	4.00	
1.99	3.41	1.95	3.63	1.92	3.89	1.89	4.16	1.84	4.45		
6WCPS 250CH											
600 700 800 900	5100		6000		6900		7800		8700		ONE AT 18/18 SC
	0.58	1.43	0.51	1.76	0.39	2.11	0.24	2.48	0.05	2.88	
	0.96	1.90	0.91	2.30	0.82	2.74	0.70	3.21	0.55	3.73	
	1.39	2.47	1.35	2.94	1.27	3.45	1.18	4.02	1.06	4.64	
1.87	3.15	1.83	3.67	1.77	4.27	1.70	4.94	1.60	5.66		
6WCPS 285CH											
700 750 800 900	5600		6500		7400		8300		9200		ONE AT 18/18 SC
	0.85	2.12	0.76	2.54	0.63	3.00	0.45	3.48	0.24	4.01	
	1.06	2.40	0.98	2.87	0.86	3.37	0.70	3.91	0.50	4.48	
	1.28	2.71	1.21	3.22	1.10	3.77	0.95	4.36	0.77	4.99	
1.77	3.43	1.70	4.00	1.61	4.65	1.49	5.35	1.33	6.08		

DIMENSIONAL DATA

MODEL 6WCP 18CH TO 6WCP 56CH

MODEL	A	B	C	D	E	F	H	J
6WCP 18CH	46	30	20	25 1/2	9 1/4	8 1/4	8 3/4	3/4
6WCP 24CH	46	30	20	25 1/2	12	8 1/4	8 3/4	3/4
6WCP 28CH	46	30	20	25 1/2	12	8 1/4	8 3/4	1
6WCP 32CH	46	30	20	32	9 1/4	10 1/2	7 1/4	1
6WCP 35CH	46	30	20	32	9 1/4	10 1/2	7 1/4	1
6WCP 46CH	46	30	20	36	11 3/4	10 1/2	7 1/4	1 1/4
6WCP 56CH	46	30	20	36	11 3/4	10 1/2	7 1/4	1 1/4

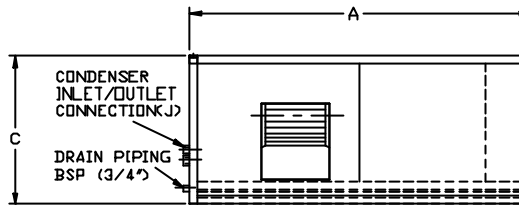
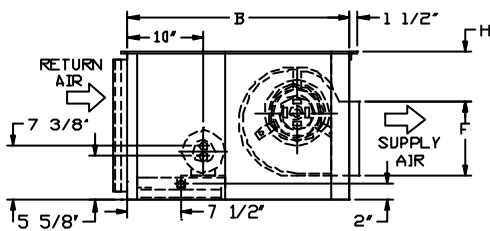
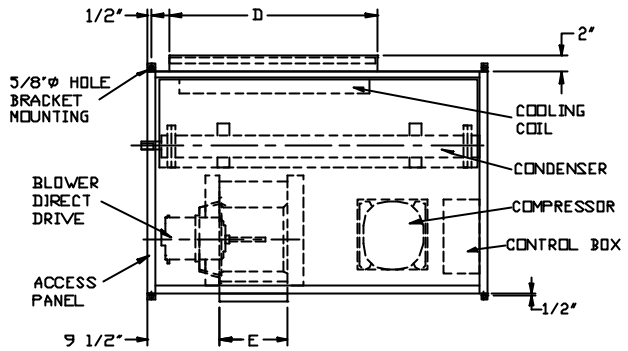

MODEL 6WCP 68CH TO 6WCPS 145CH

MODEL	A	B	C	D	E	F	G	H	J
6WCP 68CH	63	54	31 1/2	34	13	11 1/2	8	9 1/2	1 1/4
6WCPS 81CH	63	54	31 1/2	34	13	11 1/2	8	9 1/2	1 1/2
6WCPS 95CH	68	54	34 1/2	36	15 1/2	13 1/2	8	9 1/2	1 1/2
6WCPS 108CH	68	54	36	36	15 1/2	13 1/2	8	9 1/2	1 1/2
6WCPS 145CH	72	54	36	40	15 1/2	13 1/2	9	10	1 1/2

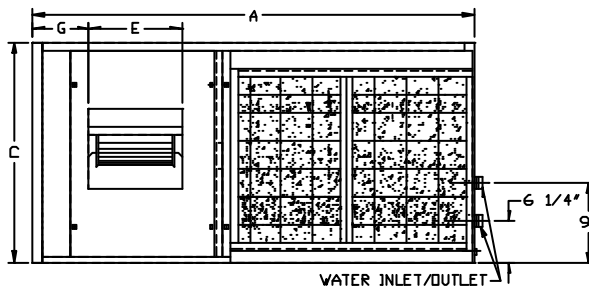
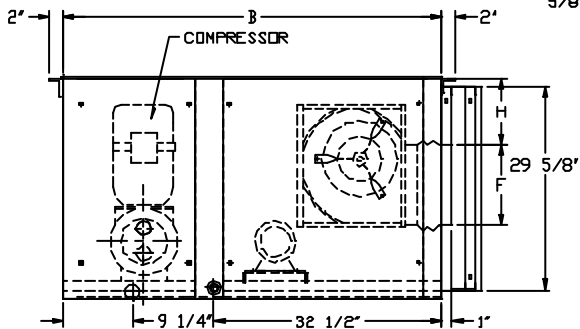
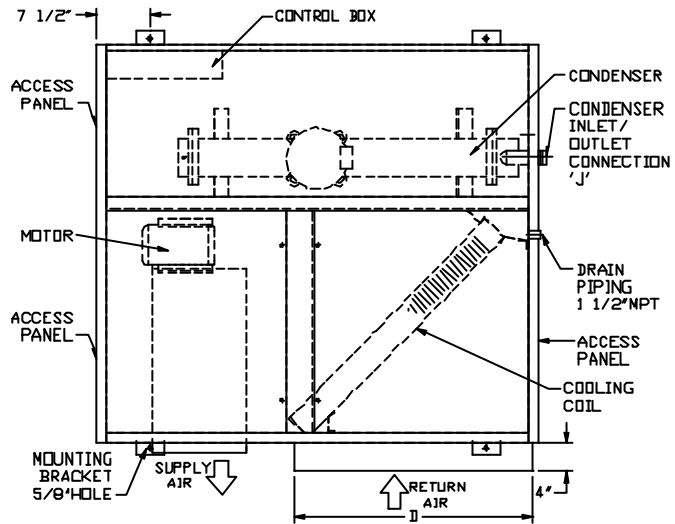

- NOTES: 1.) THE UNIT CONNECTION, LEFT/RIGHT HAND IS DETERMINED BY FACING INTO THE RETURN AIR STREAM.
 2.) ALL DIMENSIONS ARE IN INCHES.

DIMENSIONAL DATA

MODEL 6WCPS 160CH

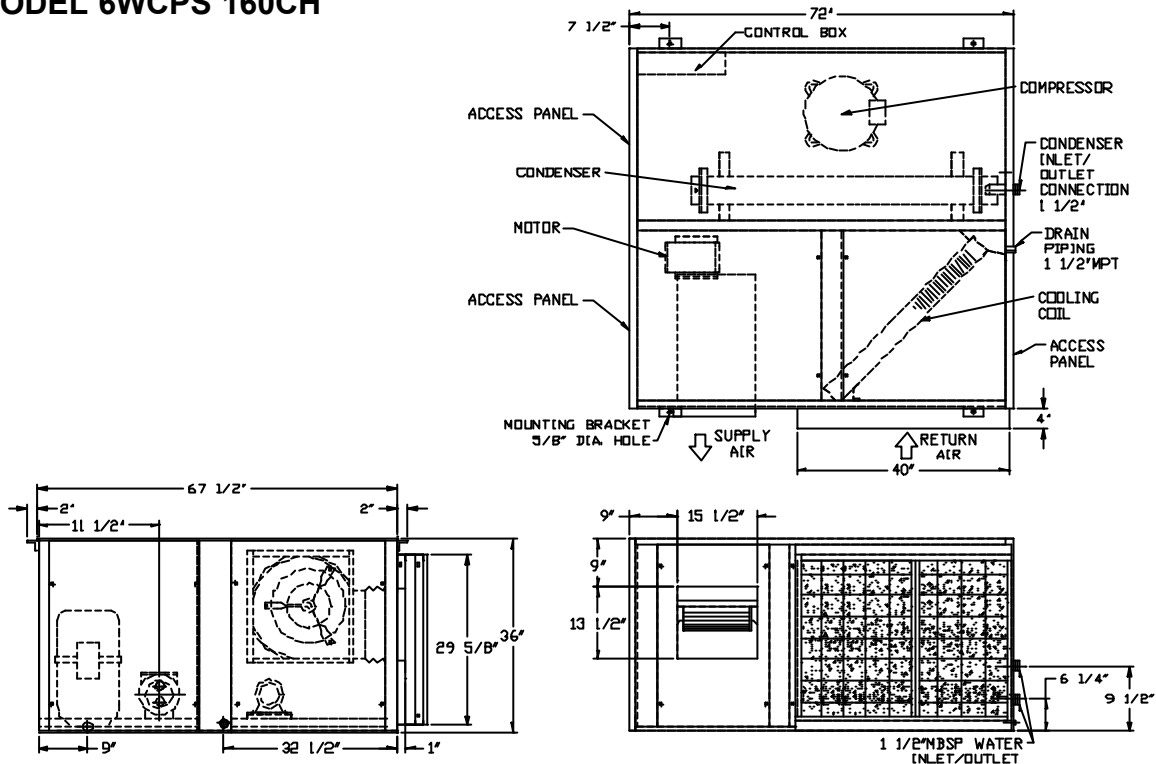

MODEL 6WCPS 190CH TO 6WCPS 285CH

MODEL	A	B	C	D	E	F	G	H	J	K	L	M
6WCPS 190CH	90	72	36	56	18 1/2	16	7 1/2	9 1/2	-	-	2	-
6WCPS 220CH	90	72	36	56	22	19	8	9 1/2	-	-	2	-
6WCPS 250CH	108	72	36	74	22	19	8	9	15 3/4	18 1/2	1 1/2	1 1/2
6WCPS 285CH	108	72	36	74	22	19	8	9 1/2	16	19 1/4	1 1/2	1 1/2

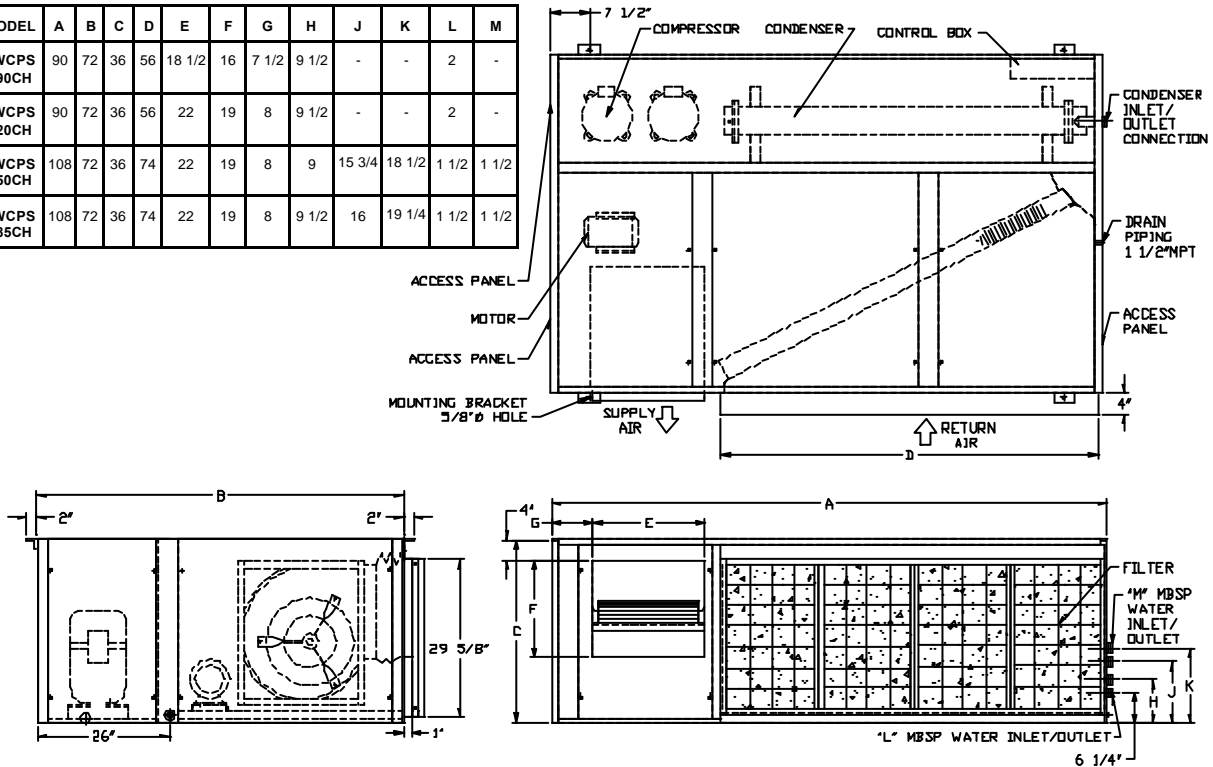

NOTES: 1.) THE UNIT CONNECTION, LEFT/RIGHT HAND IS DETERMINED BY FACING INTO THE RETURN AIR STREAM. UNIT SHOWN IN DRAWING IS RIGHT HAND CONNECTION.
 2.) ALL DIMENSIONS ARE IN INCHES.

PHYSICAL DATA

MODEL	COMPRESSOR					COND.	BLOWER SECTION						EVAP. COIL		FILTERS		REF. CHRGR	APPROX. OPERATING WEIGHT (LBS)		
	QTY	NOMINAL POWER SUPPLY	MRA EA	LRA EA	NRA EA		MIN-MAX USGPM	BLOWER			MOTOR			CFM	ROWS DEEP	TOTAL FACE AREA (FT ²)			QTY	SIZE (INCH)
								TYPE OF DRV.	QTY	DIA x WIDTH (INCH)	MAX. HP	FLA EA	LRA EA							
6WCP 18CH	1	230V -1-60Hz	1x14.0	1x45	1x5.9	4 9	DIRECT	1	7x7	0.25	1.6	-	450 850	3	1.70	1	1x20x25	1x4.80	220	
6WCP 24CH	1	230V -1-60Hz	1x17.0	1x57	1x8.0	5 12	DIRECT	1	7x9	0.50	3.3	-	600 1100	3	2.20	1	1x20x25	1x5.17	300	
6WCP 28CH	1	230V -1-60Hz	1x20.2	1x66	1x9.5	6 15	DIRECT	1	7x9	0.50	3.3	-	700 1200	3	2.40	1	1x20x25	1x5.50	280	
6WCP 32CH	1	230V -1-60Hz	1x23.0	1x76	1x11.3	6 15	DIRECT	1	9x7	0.50	3.9	-	900 1300	3	3.00	2	1x20x16	1x5.72	320	
6WCP 35CH	1	230V -1-60Hz	1x24.5	1x82	1x12.5	8 16	DIRECT	1	9x7	0.50	3.9	-	1000 1500	3	3.00	2	1x20x16	1x5.83	320	
6WCP 46CH	1	460V -3-60Hz	1x9.5	1x39	1x4.9	10 20	DIRECT	1	9x9	0.75	6.3	-	1300 1800	3	4.00	1	1x20x20 1x20x16	1x6.27	440	
6WCP 56CH	1	460V -3-60Hz	1x13.0	1x45	1x5.8	12 22	DIRECT	1	9x9	0.75	6.3	-	1500 1900	4	4.00	1	1x20x20 1x20x16	1x7.26	480	
6WCP 68CH	1	460V -3-60Hz	1x16.0	1x62	1x7.9	15 25	BELT	1	10x10	1.50	2.8	15.4	1700 2900	3	5.30	2	2x25x16	1x8.3	650	
6WCPS 81CH	1	460V -3-60Hz	1x14.0	1x74	1x7.4	15 30	BELT	1	10x10	4.00	5.4	28.8	1900 3000	4	5.30	2	2x25x16	1x9.9	800	
6WCPS 95CH	1	460V -3-60Hz	1x17.0	1x101	1x9.6	20 40	BELT	1	12x12	4.00	5.4	28.8	2800 4200	3	7.10	1	2x25x16 2x25x20	1x12.3	928	
6WCPS 108CH	1	460V -3-60Hz	1x23.0	1x95	1x10.7	22 45	BELT	1	12x12	4.00	5.4	28.8	3000 4600	3	8.40	1	2x25x16 2x25x20	1x13.2	974	
6WCPS 145CH	1	460V-3-60HZ	1x26.9	1x125	1x13.9	25 45	BELT	1	12x12	4.00	5.4	28.8	3300 5300	4	9.17	2	2x25x20	1x16.0	1150	
6WCPS 160CH	1	460V -3-60Hz	1x27.5	1x125	1x15.8	30 50	BELT	1	12x12	5.50	6.9	43.2	3400 5500	4	9.17	2	2x25x20	1x23.8	1497	
6WCPS 190CH	1	460V -3-60Hz	1x34.0	1x167	1x16.0	35 65	BELT	1	15x15	7.50	9.3	60.0	3500 6000	4	10.10	2	2x20x25 2x16x25	1x25.3	1740	
6WCPS 220CH	1	460V -3-60Hz	1x37.0	1x198	1x20.0	45 80	BELT	1	18x18	7.50	9.3	60.0	4300 7200	4	12.10	2	2x20x25 2x16x25	2x13.2	1978	
6WCPS 250CH	2	460V -3-60Hz	1x23.0 1x26.9	1x95 1x125	1x10.7 1x13.9	50 90	BELT	1	18x18	10.00	13.2	72.0	5100 9000	3	15.40	2	2x20x25 2x25x16	2x17.6	2241	
6WCPS 285CH	2	460V -3-60Hz	2x26.9	2x125	2x13.9	60 100	BELT	1	18x18	10.00	13.2	72.0	5600 9200	4	15.40	2	2x20x25 2x25x16	1x17.6 1x23.8	2465	

- Notes: 1.) NRA = Nominal Running Ampere.
 2.) LRA = Locked Rotor Ampere.
 3.) FLA = Full Load Ampere.
 4.) MRA = Maximum Running Ampere.

- 5.) Power supply for blower is 460V-3-60Hz except for 6WCP 18CH to 6WCP 56CH which is 230V-1ph-60Hz.
 6.) Minimum-maximum voltage is 230V±6%, 460V ± 6%.
 7.) For other power supply requirements, please contact the Dunham-Bush sales office.

CORRECTION FACTORS

To correct for variation in air flow, use this multiplier.

AIR FLOW VARIATION	TOTAL CAPACITY	SENSIBLE CAPACITY
0.8	0.960	0.900
0.9	0.980	0.950
1.0	1.000	1.000
1.1	1.015	1.045
1.2	1.025	1.090

To correct for altitude, use this multiplier.

ALTITUDE ABOVE SEA LEVEL - FT	COOLING CAPACITY
0	1.00
2000	0.98
3000	0.97
4000	0.96
5000	0.95
6000	0.93
7000	0.92

To correct sensible capacity for varying dry bulb.

DRY BULB	WET BULB			
	57	62	67	72
75	0.84	0.81	0.78	0.74
80	1.00	1.00	1.00	1.00
85	1.16	1.18	1.21	1.26

Note:
 If the capacity after multiplying the sensible with the correction factor exceed the total capacity, then the sensible must be equal to the total.

MANUFACTURER RESERVES THE RIGHT TO CHANGE SPECIFICATION OR DESIGN AT ANY TIME WITHOUT PRIOR NOTICE.

DUNHAM-BUSH®

Products That Perform...By People Who Care