



## SUBMERSIBLE PUMP LIFT STATION / SLUDGE LEVEL TRANSMITTER

### MODEL BC001 BIRDCAGE®

#### FEATURES:

- 3-inch diameter sensing diaphragm resists clogging
- Protective baffle plate reduces risk of sensor damage
- Corrosion-resistant, all stainless steel construction
- Stock quantities available to ship in 1 to 3 days
- Surge protection from lightning strikes and voltage spikes
- Ranges from 0-5 thru 0-500 PSI (0-10 thru 0 to 1153 meters FTWC)
- Lifetime Surge Warranty Replacement Program when partnered with the BCP3000 Surge Protector (sold separately)

#### APPLICATIONS:

- Submersible pump lift station level monitoring
- Wet wells
- Process sumps
- Water tanks and reservoirs
- Process sludge
- Water and wastewater level monitoring

#### PRODUCT OVERVIEW:

The BC001 Birdcage® Series from Blue Ribbon Corporation is a highly accurate level transmitter designed specifically for sludge level monitoring and pump lift stations. Its all stainless steel design incorporates a 3-inch diameter clog-resistant sensing diaphragm and corrosion resistant protective baffle plate. These features, combined with over 25 years of proven field service, make the Birdcage® the industry standard in water and wastewater level measurement.

#### FIELD OPTIONS:

- 4-20 mA or 0-5 Vdc Output
- FM/CSA Hazardous approvals
- Temperature Output
- External Lightning Surge Protection Package



Model BC001 Birdcage®



# SUBMERSIBLE PUMP LIFT STATION / SLUDGE LEVEL TRANSMITTER

## DIMENSIONAL DRAWING

All dimensions are in inches (mm)

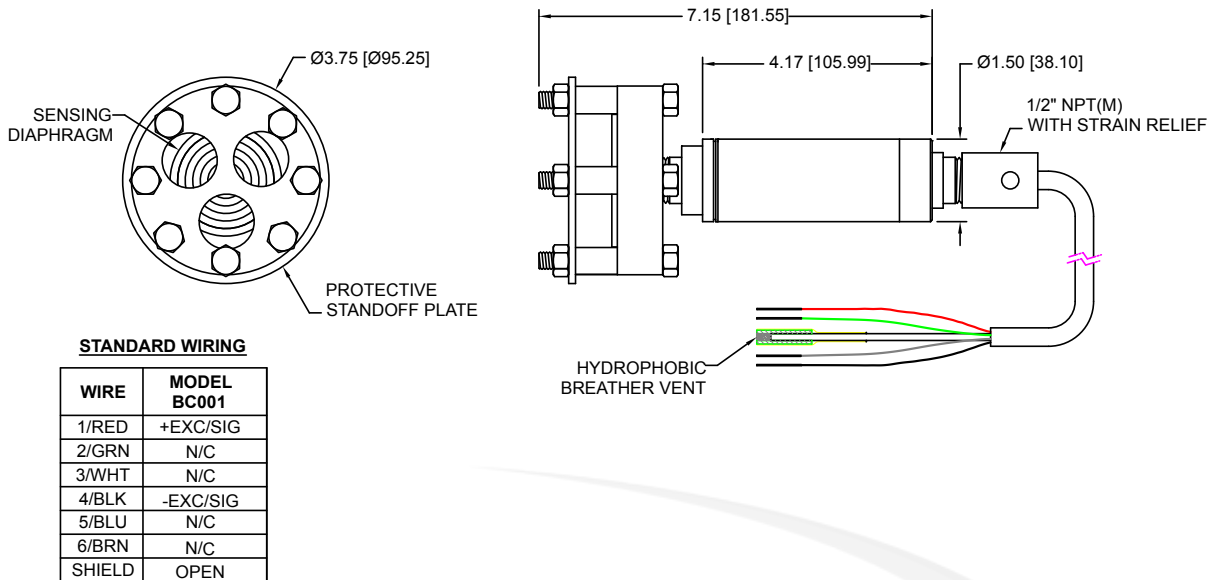

### STANDARD WIRING

WIRE	MODEL BC001
1/RED	+EXC/SIG
2/GRN	N/C
3/WHT	N/C
4/BLK	-EXC/SIG
5/BLU	N/C
6/BRN	N/C
SHIELD	OPEN

## REFERENCE SPECIFICATIONS

### ELECTRICAL

- **Supply Voltage:** 9 to 36 Vdc
- **Output Signal:** 4-20 mA
- **Circuit Protection:** RFI and EMI surge protection
- **Load Impedance:** 1,350  $\Omega$  max. at 36 Vdc and 750  $\Omega$  at 24 Vdc
- **Input Current:** 8 mA, nominal
- **Insulation Resistance:** >10 M $\Omega$  at 50 Vdc and +70 °F
- **Connection:** 1/2" NPT (M) conduit with 40 feet of 3-conductor, 18 AWG Hytrel jacketed cable (optional Tefzel jacketing)

### MATERIALS OF CONSTRUCTION

316 stainless steel

### THERMAL SPECIFICATIONS

- **Compensated:** 0 °F to +140 °F (-18 °C to +60 °C)
- **Operating Ambient:** -40 °F to +150 °F (-40 °C to +66 °C)
- **Effect on Zero Span**  $\pm 2\%$  FSO/100 °F

### STATIC ACCURACY (RSS) (HYSTERESIS, NON-LINEARITY & REPEATABILITY @ +70 °F)

- **Standard:**  $\pm 0.5\%$
- **Optional:**  $\pm 0.2\%$
- **Zero Balance and FSO:**  $\pm$  FSO at +70 °F

### MECHANICAL

- **Process connection:** Oil filled diaphragm
- **Proof Pressure:** 2X FSO or 22,500 PSI (1,551 BAR), whichever is less
- **Burst Pressure:** 5X FSO or 22,500 PSI (1,551 BAR), whichever is less
- **External Pressure:** 500 PSI max. (35 BAR)
- **Weight:** 5.5 lb (2.5 kg)

### PRESSURE RANGES

0-5 thru 0-500 PSI (0-10 FTWC thru 0-1153 FTWC)  
0-3 thru 0-335 meters WC

All specifications are for reference purposes only. In the interests of continuous product improvement, all specifications are subject to change without notice. Please contact Blue Ribbon Corporation for assistance with your application.

