

# DUNHAM-BUSH®

*Products That Perform...By People Who Care*

FORM NO: MS0215A

## WATER-COOLED PACKAGED



## 60 Hz

**6WCPS-B SERIES  
6WCPR-B SERIES**

### **New Features:**

- Compact Design
- Tandem Compressors
- Single Large Diameter Blower Wheel
- Single Side Return



# WATER-COOLED PACKAGE UNITS

## GENERAL DESCRIPTION

The 6WCPS/R series with new features is suitable for hotel, office, hospital, schools, factory and supermarket applications. The low noise and compact series are completely leak tested, evacuated, dehydrated and precharged with refrigerant so that it is ready for connection when reached the site.

## Scroll Compressor(s)

(6WCPS Series)

### Reliability

- \* No contact scroll design that minimizes friction, increases volumetric efficiency and reduces vibration, thus longer service life.
- \* Suction gas cooled motor.

### Low Power Consumption:

- \* High EER.
- \* No crankcase heater required.



## Tandem Compressor

(6WCPS 445B to 1520B)

For model with 3 compressors system and above, two compressors are connected in tandem, thus reducing the number of condenser water inlet/outlet connection.



## Large Reciprocating Compressor

(6WCPR 540B to 1280B)

- \* A combination of 2 to 4 reciprocating compressors to reduce the condenser piping connection. Also, this will reduce the quantity of electrical starter components.

## Multiple Compressor

(6WCPS 220B to 1520B and 6WCPR 540B to 1280B)

- \* By cycling off compressor(s) operation to match building load, no energy is being wasted when room load requires lesser cooling capacity.
- \* No total shut down when servicing or repairing a faulty compressor.

## Cleanable Shell and Tube Condenser

- \* Multiple 3/4" O.D. copper finned tubes with 25 to 30% more surface area ensure better heat transfer.
- \* Integral subcooling circuit to maximize efficiency.
- \* Provided with fusible plug for safety purpose.
- \* Leak and pressure tested to 450 psig.

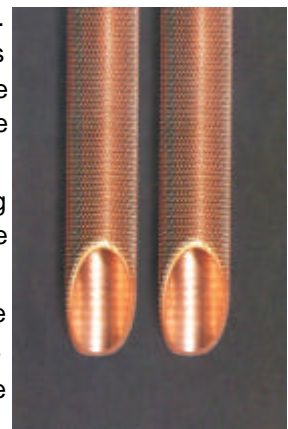

## Fully Leak Tested Refrigerant Circuit

- \* Leak and pressure tested at 450 psig.
- \* Pressure ports are provided on the discharge, liquid and suction line.
- \* Evacuated, dehydrated and charged with refrigerant.

## Safety Components

- \* High-low pressure cutout to protect compressor from high discharge pressure and system leakage.
- \* Liquid line sight glass and filter drier for refrigerant line components.

## Efficient Evaporator Coil

- \* Independent thermal expansion valve with external equalizer for better refrigerant control and wider load condition.
- \* Leak and pressure tested to 450 psig
- \* Evacuated, dehydrated and charged with refrigerant.



# SYSTEM COOLING CAPACITY

## PERFORMANCE DATA

MODEL	STD CAPACITY MBH	AIR ON EVAP.		WATER TEMPERATURE OFF CONDENSER - °F								
		CFM	WB TEMP. °F	80			95			110		
				TOTAL MBH'	SENS MBH²	KW³	TOTAL MBH'	SENS MBH²	KW³	TOTAL MBH'	SENS MBH²	KW³
6WCPS 81B	81	2400	72	91.1	44.3	3.8	85.8	41.4	4.1	74.5	39.3	4.2
			67	86.9	56.4	3.6	81.0	54.2	4.0	76.8	52.6	4.1
			62	79.3	67.8	3.6	73.3	65.3	3.9	70.0	63.5	4.1
			57	70.0	70.0	3.5	64.8	64.8	3.9	61.5	61.5	4.1
6WCPS 95B	95	2800	72	106.9	57.0	4.7	100.7	53.6	5.1	90.9	50.7	5.3
			67	101.9	75.8	4.5	95.0	70.8	5.0	90.1	67.0	5.2
			62	93.1	92.4	4.5	87.1	86.6	4.8	82.2	82.2	5.1
			57	82.3	82.3	4.4	76.1	76.1	4.8	72.2	72.2	5.1
6WCPS108B	108	3500	72	121.6	64.8	5.3	114.5	61.1	5.6	108.0	57.6	5.9
			67	115.9	86.2	5.1	108.0	80.4	5.6	102.4	76.2	5.9
			62	105.9	105.1	5.0	99.1	98.4	5.5	93.5	93.5	5.7
			57	93.5	93.5	5.0	86.6	86.6	5.4	82.1	82.1	5.7
6WCPS 145B	145	4000	72	163.2	76.9	10.3	153.7	72.4	11.0	145.0	68.3	11.6
			67	155.6	101.5	9.7	145.0	94.6	10.7	137.3	89.6	11.1
			62	142.0	123.7	9.7	132.9	115.8	10.6	125.4	110.2	11.0
			57	125.4	110.2	9.5	116.3	102.2	10.6	110.2	96.8	11.0
6WCPS 160B	160	4200	72	179.9	102.7	8.0	169.5	96.7	8.6	159.9	91.1	8.9
			67	171.6	139.1	7.8	160.0	129.6	8.4	151.7	122.9	8.8
			62	156.6	156.6	7.7	146.7	146.7	8.2	138.3	138.3	8.6
			57	138.3	138.3	7.4	127.9	127.9	8.2	121.6	121.6	8.6
6WCPS 190B	190	5800	72	213.7	84.5	9.2	201.4	107.2	9.9	190.0	101.1	10.2
			67	203.8	150.1	8.7	190.0	139.9	9.6	180.1	132.6	10.0
			62	186.0	182.6	8.7	174.1	171.0	9.3	164.3	164.3	9.9
			57	163.6	163.6	8.5	152.3	152.3	9.3	144.4	144.4	9.9
6WCPS 220B	220	6400	72	248.8	144.6	10.9	234.5	136.3	11.9	220.0	127.8	12.2
			67	233.4	192.9	10.4	220.0	181.8	11.5	206.6	170.7	12.0
			62	215.6	215.6	10.4	204.4	204.4	11.1	178.0	178.0	11.9
			57	195.6	195.6	10.2	173.4	173.4	11.1	170.0	170.0	11.9
6WCPS 250B	250	6800	72	281.2	148.5	12.4	264.9	139.8	13.5	249.9	131.9	13.8
			67	265.2	194.7	11.8	250.0	183.5	13.0	236.9	174.0	13.6
			62	244.6	230.2	11.8	228.3	228.3	12.6	216.2	216.2	13.5
			57	222.1	222.1	11.6	200.4	200.4	12.6	189.9	189.9	13.5
6WCPS 285B	285	7800	72	320.2	160.8	14.1	301.6	151.5	15.0	283.0	142.2	15.9
			67	300.2	206.3	14.0	285.0	194.5	14.9	265.9	182.7	15.8
			62	277.3	248.5	13.8	263.0	235.7	14.8	245.9	220.3	15.7
			57	251.6	251.6	13.7	237.3	237.3	14.7	230.0	230.0	15.6
6WCPS 320B	320	8400	72	362.1	180.8	15.9	341.1	170.3	17.2	320.1	159.9	17.7
			67	343.5	230.3	15.1	320.0	217.0	16.7	300.7	203.9	17.5
			62	313.4	275.8	15.1	297.5	261.3	16.2	278.1	244.6	17.2
			57	284.5	284.5	14.9	268.4	268.4	16.2	260.0	260.0	17.2
6WCPS 380B	380	10500	72	427.4	221.9	18.2	405.9	209.1	19.7	380.0	197.4	20.3
			67	407.7	292.5	17.3	380.0	272.6	19.1	360.2	258.5	20.0
			62	371.9	353.9	17.3	348.4	331.6	18.5	328.6	312.8	19.7
			57	328.6	328.6	17.0	318.5	318.5	18.5	308.0	308.0	19.7
6WCPS 445B	445	11500	72	481.3	242.2	22.0	453.4	228.1	23.4	425.4	214.0	24.8
			67	451.2	362.9	21.9	445.0	292.3	23.2	399.6	274.6	24.7
			62	416.8	375.0	21.5	395.3	355.6	23.1	369.5	332.4	24.5
			57	378.2	378.2	21.4	356.7	356.7	22.8	350.0	350.0	24.4
6WCPS 480B	480	13500	72	543.0	271.5	23.8	511.4	255.8	25.3	479.9	240.0	26.8
			67	509.0	344.6	23.6	480.0	325.1	25.1	450.8	305.4	26.7
			62	470.2	414.3	23.2	445.9	393.0	24.9	416.9	367.3	26.5
			57	426.6	426.6	23.0	402.4	402.4	24.7	396.0	396.0	26.3
6WCPS 510B	510	14500	72	577.0	288.5	25.0	543.5	271.8	26.5	510.0	255.0	28.1
			67	540.9	366.2	24.7	510.0	345.5	26.3	479.1	324.5	28.0
			62	499.7	440.3	24.4	473.9	417.6	26.1	443.0	390.3	27.8
			57	453.3	453.3	24.1	427.6	427.6	25.9	420.0	420.0	27.6
6WCPR 540B	540	15500	72	611.2	309.9	33.0	575.4	291.8	35.1	540.0	273.8	37.2
			67	572.7	379.8	32.8	540.0	374.1	34.8	507.3	351.4	37.1
			62	529.1	479.5	32.3	501.8	409.1	34.5	469.1	399.6	36.8
			57	480.0	480.0	32.0	452.8	452.8	34.3	448.3	448.3	36.5
6WCPS 570B	570	15500	72	645.0	324.0	27.2	607.6	305.2	28.9	570.1	286.3	30.7
			67	604.7	414.4	27.0	570.0	397.4	28.7	535.5	367.1	30.6
			62	558.6	500.5	26.6	529.8	474.7	28.5	495.2	443.7	30.4
			57	506.8	506.8	26.4	478.0	478.0	28.3	470.0	470.0	30.1

Notes: 1.) Ratings are gross capacities. For net capacities, deduct evaporator blower mot or heat.  
2.) At 80°F (26.6°C) DB air on evaporator.  
3.) Compressor KW input.

# SYSTEM COOLING CAPACITY

## PERFORMANCE DATA

MODEL	STD CAPACITY MBH	AIR ON EVAP.		WATER TEMPERATURE OFF CONDENSER - °F								
		CFM	WB TEMP. °F	80			95			110		
				TOTAL MBH'	SENS MBH²	KW³	TOTAL MBH'	SENS MBH²	KW³	TOTAL MBH'	SENS MBH²	KW³
6WCPS 640B	640	17000	72	724.0	360.4	31.7	682.0	339.5	33.6	640.0	318.6	35.8
			67	678.8	455.8	31.5	640.0	429.7	33.4	601.2	403.7	35.5
			62	627.1	550.1	31.0	594.8	521.8	33.2	556.0	487.8	35.3
			57	568.9	568.9	30.7	536.6	536.6	32.9	530.0	530.0	35.1
6WCPR 640B	640	17000	72	724.4	367.4	41.3	682.0	345.9	43.9	640.0	324.6	46.6
			67	678.8	450.2	41.1	640.0	443.5	43.6	601.2	416.6	46.5
			62	627.1	568.5	40.5	594.7	485.0	43.3	555.9	473.7	46.1
			57	568.9	568.9	40.1	536.6	536.6	43.0	531.3	531.3	45.8
6WCPS 700B	700	18000	72	792.2	396.0	34.0	746.2	372.9	36.1	700.2	350.0	38.3
			67	742.7	503.2	33.6	700.0	474.5	35.8	657.8	445.6	38.1
			62	686.0	605.0	33.2	650.7	573.9	35.6	608.3	536.4	37.9
			57	622.4	622.4	32.9	587.0	587.0	35.3	581.0	581.0	37.6
6WCPS 760B	760	20000	72	859.7	429.7	36.3	809.7	404.7	38.5	759.9	379.8	40.9
			67	806.0	546.0	35.9	760.0	514.9	38.2	713.8	483.6	40.7
			62	744.5	656.6	35.4	706.2	622.8	37.9	660.1	582.2	40.4
			57	675.5	675.5	35.1	637.0	637.0	37.7	630.0	630.0	40.1
6WCPS 800B	800	22000	72	905.0	452.3	39.6	852.4	426.0	42.0	799.9	399.9	44.7
			67	848.4	574.8	39.2	800.0	542.0	41.8	751.4	509.1	44.4
			62	783.7	691.2	38.7	743.4	655.6	41.4	694.9	612.8	44.1
			57	711.1	711.1	38.4	670.6	670.6	41.1	665.0	665.0	43.8
6WCPR 810B	810	22000	72	916.8	464.9	49.5	863.2	437.7	52.6	810.0	410.8	55.8
			67	859.1	569.7	49.2	810.0	561.2	52.2	760.9	527.1	55.6
			62	793.6	719.4	48.4	752.7	613.7	51.8	703.6	599.5	55.2
			57	720.0	720.0	48.0	679.1	679.1	51.5	672.5	672.5	54.8
6WCPS 860B	860	24000	72	973.3	554.0	42.1	916.3	521.5	44.8	859.9	489.4	47.6
			67	912.1	678.8	41.9	860.0	668.6	44.4	807.8	627.9	47.4
			62	842.5	857.0	41.2	799.1	731.1	44.1	746.9	684.3	47.0
			57	764.3	864.4	40.9	721.0	815.4	43.8	715.1	808.7	46.7
6WCPS 950B	950	26000	72	1075.3	546.8	45.5	1012.3	514.8	48.4	950.0	483.1	51.4
			67	1007.6	670.0	45.2	950.0	660.0	48.0	892.4	619.9	51.2
			62	930.8	846.0	44.6	882.8	721.7	47.6	825.2	705.0	50.8
			57	844.4	853.3	44.2	796.5	804.9	47.3	788.7	797.0	50.4
6WCPR 960B	960	26000	72	1086.6	550.9	62.0	1023.0	518.7	65.9	960.0	486.8	70.0
			67	1018.2	675.1	61.6	960.0	665.0	65.4	901.8	624.6	69.7
			62	940.6	852.4	60.7	892.1	727.2	64.9	833.9	710.3	69.2
			57	853.3	853.3	60.2	804.9	804.9	64.5	797.0	797.0	68.7
6WCPR 1080B	1080	26000	72	1222.4	619.9	66.0	1150.9	583.6	70.2	1080.0	547.7	74.5
			67	1145.5	759.5	65.6	1080.0	748.2	69.6	1014.5	702.7	74.2
			62	1058.2	959.1	64.6	1003.6	818.1	69.0	938.1	799.2	73.6
			57	960.0	960.0	64.0	905.5	905.5	68.6	896.6	896.6	73.1
6WCPS 1140B	1140	28000	72	1290.9	649.6	54.4	1215.3	611.6	57.8	1140.5	573.9	61.3
			67	1209.6	796.0	54.1	1140.0	784.1	57.4	1071.3	736.4	61.1
			62	1117.4	1005.0	53.2	1059.8	857.4	56.9	990.7	840.0	60.7
			57	1013.7	1013.7	52.8	956.2	956.2	56.5	950.0	950.0	60.2
6WCPR 1180B	1180	28000	72	1335.6	677.4	74.3	1257.4	637.7	79.0	1180.0	598.5	83.9
			67	1251.5	830.0	73.9	1180.0	817.6	78.4	1108.5	767.9	83.6
			62	1156.2	1048.0	72.8	1096.5	894.0	77.8	1025.0	873.3	82.9
			57	1048.8	1048.8	72.1	989.4	989.4	77.3	979.6	979.6	82.3
6WCPR 1280B	1280	32000	72	1448.8	734.9	82.7	1364.0	691.9	87.9	1280.0	649.3	93.3
			67	1357.6	900.4	82.2	1280.0	887.0	87.2	1202.4	833.1	92.9
			62	1254.1	1137.0	80.9	1189.5	969.9	86.5	1111.9	947.5	92.2
			57	1137.7	1137.7	80.2	1073.2	1073.2	86.0	1062.7	1062.7	91.6
6WCPS 1340B	1340	32000	72	1516.9	763.3	65.7	1428.1	718.7	69.7	1340.2	674.4	74.0
			67	1421.4	935.3	65.2	1340.0	921.4	69.2	1258.9	865.4	73.7
			62	1313.1	1181.0	64.2	1245.4	1007.5	68.7	1164.1	997.0	73.2
			57	1191.2	1191.2	63.7	1123.6	1123.6	68.2	1110.0	1110.0	72.7
6WCPS 1520B	1520	36000	72	1720.1	865.6	72.5	1619.4	814.9	77.0	1519.7	764.7	81.8
			67	1611.8	1060.6	72.1	1520.0	1044.8	76.5	1427.5	981.3	81.4
			62	1489.0	1339.2	71.0	1412.2	1142.5	75.9	1320.1	1104.0	80.9
			57	1350.8	1350.8	70.4	1274.2	1274.2	75.4	1204.0	1204.0	80.3

Notes: 1.) Ratings are gross capacities. For net capacities, deduct evaporator blower motor heat.  
2.) At 80°F (26.6°C) DB air on evaporator.  
3.) Compressor KW input.

# BLOWER PERFORMANCE

Available External Static Pressure - IWG - For Accessories And Duct System Static Resistance (Allowance Made For Wet Coil And Filters)

RPM	CFM										FAN MODEL
	TSP	BHP	TSP	BHP	TSP	BHP	TSP	BHP	TSP	BHP	
<b>6WCPS 108B</b>											
	2900		3200		3500		3800		4100		12 x 12 (inch)
800	1.02	0.96	1.01	1.11	0.98	1.27	0.94	1.46	0.87	1.65	
900	1.31	1.17	1.30	1.34	1.28	1.51	1.26	1.72	1.22	1.92	
1000	1.61	1.39	1.62	1.58	1.60	1.78	1.59	2.00	1.56	2.25	
1100	1.89	1.63	1.95	1.86	1.96	2.09	1.94	2.32	1.92	2.59	
<b>6WCPS 145B</b>											
	3100		3400		3700		4000		4300		12 x 12 (inch)
900	1.30	1.26	1.29	1.45	1.27	1.65	1.24	1.86	1.18	2.09	
1000	1.63	1.51	1.61	1.72	1.59	1.93	1.57	2.17	1.54	2.43	
1100	1.93	1.80	1.97	2.01	1.95	2.25	1.93	2.51	1.91	2.79	
1200	2.22	2.08	2.30	2.35	2.35	2.61	2.32	2.88	2.30	3.19	
<b>6WCPS 160B</b>											
	3300		3600		3900		4200		4500		12 x 12 (inch)
900	1.29	1.39	1.27	1.58	1.24	1.78	1.21	2.01	1.14	2.25	
1000	1.61	1.65	1.60	1.86	1.58	2.09	1.55	2.32	1.52	2.60	
1100	1.97	1.93	1.96	2.18	1.94	2.43	1.92	2.68	1.89	2.99	
1200	2.28	2.25	2.34	2.51	2.33	2.80	2.31	3.08	2.29	3.39	
<b>6WCPS 190B</b>											
	5000		5400		5800		6200		6600		15 x 15 (inch)
800	1.35	2.18	1.34	2.47	1.30	2.76	1.08	3.11	0.70	3.50	
900	1.74	2.60	1.72	2.91	1.71	3.26	1.69	3.63	1.63	3.99	
1000	2.15	3.06	2.15	3.40	2.14	3.82	2.11	4.21	2.10	4.65	
1100	2.61	3.66	2.61	3.99	2.61	4.41	2.60	4.86	2.57	5.32	
<b>6WCPS 220B</b>											
	5600		6000		6400		6800		7200		15 x 15 (inch)
850	1.52	2.85	1.49	3.16	1.39	3.51	1.00	3.94	0.60	4.40	
900	1.71	3.10	1.70	3.44	1.66	3.81	1.53	4.19	1.13	4.69	
1000	2.15	3.62	2.12	3.99	2.11	4.42	2.09	4.88	2.04	5.33	
1100	2.61	4.19	2.61	4.61	2.58	5.09	2.56	5.59	2.55	6.11	
<b>6WCPS 250B</b>											
	5600		6000		6400		6800		7200		15 x 15 (inch)
850	1.52	2.85	1.49	3.16	1.39	3.51	1.00	3.94	0.60	4.40	
900	1.71	3.10	1.70	3.44	1.66	3.81	1.53	4.19	1.13	4.69	
1000	2.15	3.62	2.12	3.99	2.11	4.42	2.09	4.88	2.04	5.33	
1100	2.61	4.19	2.61	4.61	2.58	5.09	2.56	5.59	2.55	6.11	
<b>6WCPS 285B</b>											
	6200		6800		7400		8000		8600		18 x 13 (inch)
800	2.02	3.63	1.94	4.13	1.86	4.62	1.78	5.16	1.44	5.79	
900	2.59	4.41	2.58	5.01	2.50	5.57	2.40	6.26	2.32	6.89	
1000	3.22	5.27	3.21	5.94	3.20	6.69	3.12	7.37	3.01	8.19	
1100	3.87	6.20	3.91	6.99	3.88	7.77	3.87	8.71	3.81	9.55	
<b>6WCPS 320B</b>											
	6600		7200		7800		8400		8800		18 x 13 (inch)
850	2.28	4.37	2.19	4.92	2.11	5.51	2.08	4.92	2.12	5.13	
900	2.59	4.82	2.52	5.36	2.43	6.03	2.34	6.66	2.28	7.12	
1000	3.21	5.71	3.20	6.46	3.15	7.16	3.05	7.91	2.98	8.46	
1100	3.90	6.71	3.89	7.54	3.88	8.42	3.84	9.29	3.78	9.81	
<b>6WCPS 380B</b>											
	7600		8400		9200		10000		10800		18 x 18 (inch)
700	1.45	3.54	1.39	4.14	1.24	4.80	0.98	5.47	0.78	6.28	
750	1.70	3.93	1.65	4.57	1.58	5.25	1.38	6.02	1.10	6.82	
800	1.96	4.33	1.92	4.98	1.85	5.75	1.77	6.58	1.53	7.48	
850	2.23	4.80	2.20	5.52	2.15	6.31	2.08	7.20	1.94	8.12	
<b>6WCPS 445B</b>											
	8600		9400		10200		11000		11800		18 x 18 (inch)
700	1.37	4.27	1.18	4.94	0.93	5.68	0.72	6.46	0.45	7.28	
750	1.64	4.73	1.55	5.44	1.30	6.22	1.04	7.06	0.83	7.97	
800	1.91	5.20	1.83	5.96	1.70	6.79	1.45	7.71	1.18	8.68	
850	2.19	5.71	2.13	6.53	2.05	7.41	1.87	8.35	1.59	9.38	
<b>6WCPS 480B</b>											
	8000		9500		11000		12500		14000		500 x 500 (mm)
550	1.10	2.64	1.03	3.35	0.92	4.19	0.75	5.09	0.54	6.14	
650	1.58	3.58	1.54	4.41	1.45	5.37	1.34	6.49	1.16	7.75	
750	2.10	4.70	2.10	5.65	2.04	6.78	1.95	8.09	1.82	9.55	
850	2.63	6.00	2.71	7.10	2.69	8.44	2.62	9.92	2.52	11.58	

Note: Data shown for Class 1 fan construction.

# BLOWER PERFORMANCE

Available External Static Pressure - IWG - For Accessories And Duct System Static Resistance (Allowance Made For Wet Coil And Filters)

RPM	CFM										FAN MODEL
	TSP	BHP	TSP	BHP	TSP	BHP	TSP	BHP	TSP	BHP	
<b>6WCPS 510B</b>											
	10000		11500		13000		14500		16000		560 x 560 (mm)
500	1.19	3.34	1.15	4.03	1.07	4.78	0.97	5.67	0.85	6.62	
600	1.75	4.64	1.73	5.45	1.68	6.41	1.62	7.48	1.50	8.59	
700	2.32	6.28	2.38	7.21	2.38	8.33	2.32	9.58	2.24	10.92	
800	2.95	8.35	3.02	9.41	3.10	10.65	3.11	12.15	3.06	13.74	
<b>6WCPS 570B &amp; 6WCPR 540B</b>											
	11000		13500		15000		15800		16500		560 x 560 (mm)
550	1.45	4.48	1.35	5.90	1.25	6.89	1.18	7.41	1.12	7.91	
650	2.05	6.00	2.01	7.73	1.93	8.86	1.89	9.58	1.84	10.17	
700	2.35	6.91	2.36	8.76	2.29	10.00	2.25	10.75	2.21	11.35	
800	3.00	9.03	3.11	11.16	3.11	12.57	3.08	13.55	3.05	14.30	
<b>6WCPS 640B &amp; 6WCPR 640B</b>											
	14600		15400		16200		17000		17800		560 x 560 (mm)
550	1.28	6.61	1.21	7.10	1.16	7.75	1.09	8.32	1.01	8.96	
650	1.95	8.58	1.91	9.18	1.85	9.89	1.80	10.61	1.73	11.40	
700	2.32	9.66	2.27	10.39	2.23	11.08	2.18	11.91	2.12	12.69	
750	2.71	10.93	2.67	11.67	2.63	12.46	2.59	13.33	2.54	14.15	
<b>6WCPS 700B</b>											
	15600		16400		17200		18000		18800		560 x 560 (mm)
550	1.20	7.26	1.14	7.88	1.06	8.47	0.99	9.11	0.90	9.80	
600	1.54	8.27	1.48	8.95	1.40	9.57	1.35	10.33	1.26	11.04	
650	1.90	9.39	1.84	10.06	1.78	10.81	1.70	11.54	1.63	12.35	
700	2.28	10.64	2.22	11.23	2.18	12.17	2.12	12.92	2.05	13.87	
<b>6WCPS 760B</b>											
	13000		15000		17000		19000		21000		630 x 630 (mm)
500	1.48	5.49	1.43	6.54	1.36	7.87	1.12	9.43	0.60	11.16	
550	1.82	6.58	1.78	7.72	1.72	9.11	1.62	10.68	1.32	12.64	
600	2.17	7.73	2.15	9.09	2.10	10.56	2.02	12.15	1.90	14.19	
650	2.52	8.98	2.54	10.55	2.50	12.15	2.44	13.91	2.36	15.95	
<b>6WCPS 800B &amp; 6WCPR 810B</b>											
	15000		17000		19000		21000		23000		630 x 630 (mm)
550	1.78	7.72	1.72	9.11	1.63	10.69	1.32	12.64	0.75	14.74	
600	2.15	9.09	2.09	10.52	2.03	12.19	1.90	14.19	1.54	16.50	
640	2.46	10.25	2.42	11.82	2.35	13.49	2.27	15.62	2.09	18.00	
680	2.78	11.40	2.76	13.21	2.69	15.02	2.62	17.14	2.52	19.62	
<b>6WCPS 860B</b>											
	17000		19000		21000		23000		25000		710 x 710 (mm)
400	1.19	5.88	1.12	6.86	1.04	8.08	0.82	9.39	0.40	10.92	
450	1.55	7.18	1.51	8.31	1.44	9.55	1.35	10.97	1.19	12.64	
500	1.92	8.58	1.92	9.96	1.86	11.28	1.79	12.85	1.70	14.58	
600	2.72	12.17	2.76	13.61	2.77	15.42	2.74	17.29	2.69	19.32	
<b>6WCPS 950B &amp; 6WCPR 960B, 1080B</b>											
	19000		21000		23000		25000		27000		710 x 710 (mm)
450	1.51	8.31	1.44	9.55	1.35	10.97	1.18	12.62	0.77	14.45	
500	1.91	9.92	1.86	11.28	1.79	12.85	1.70	14.58	1.58	16.47	
600	2.76	13.61	2.77	15.42	2.74	17.29	2.69	19.32	2.61	21.53	
650	3.22	15.93	3.25	17.65	3.25	19.86	3.22	22.10	3.16	24.46	
<b>6WCPS 1140B &amp; 6WCPR 1180B</b>											
	20000		22000		24000		26000		28000		TWIN 560 x 560 (mm)
500	1.10	6.74	1.06	7.64	1.01	8.62	0.96	9.76	0.89	10.89	
600	1.62	9.33	1.61	10.39	1.58	11.62	1.53	12.90	1.49	14.36	
700	2.15	12.50	2.20	13.74	2.20	15.28	2.19	16.82	2.15	18.44	
800	2.74	16.48	2.80	17.94	2.85	19.71	2.87	21.35	2.88	23.36	
<b>6WCPS 1340B &amp; 6WCPR 1280B</b>											
	25000		27000		29000		31000		33000		TWIN 560 x 560 (mm)
500	0.99	9.15	0.92	10.22	0.85	11.43	0.78	12.82	0.68	14.15	
600	1.55	12.23	1.52	13.59	1.45	15.03	1.38	16.63	1.30	18.24	
700	2.20	15.93	2.17	17.67	2.12	19.30	2.08	21.16	2.00	23.05	
800	2.87	20.41	2.87	22.36	2.87	24.19	2.83	26.53	2.78	28.66	
<b>6WCPS 1520B</b>											
	28000		30000		32000		34000		36000		TWIN 560 x 560 (mm)
500	0.89	10.89	0.82	12.15	0.73	13.45	0.62	14.77	0.52	16.36	
600	1.48	14.31	1.43	15.83	1.34	17.39	1.27	19.20	1.18	20.98	
700	2.14	18.37	2.10	20.27	2.05	22.08	1.98	24.13	1.90	26.32	
800	2.87	23.28	2.85	25.42	2.80	27.46	2.74	29.84	2.70	32.19	

Note: Data shown for Class 1 fan construction.

# DIMENSIONAL DATA

## 6WCPS 81B, 95B

MODEL	A	B	C	D	E	F	G	H	P
6WCPS 81B	47	50	30	15 1/2	13 1/2	15 3/4	15 3/4	35	1 1/2
6WCPS 95B	47	50	30	15 1/2	13 1/2	15 3/4	15 3/4	35	1 1/2

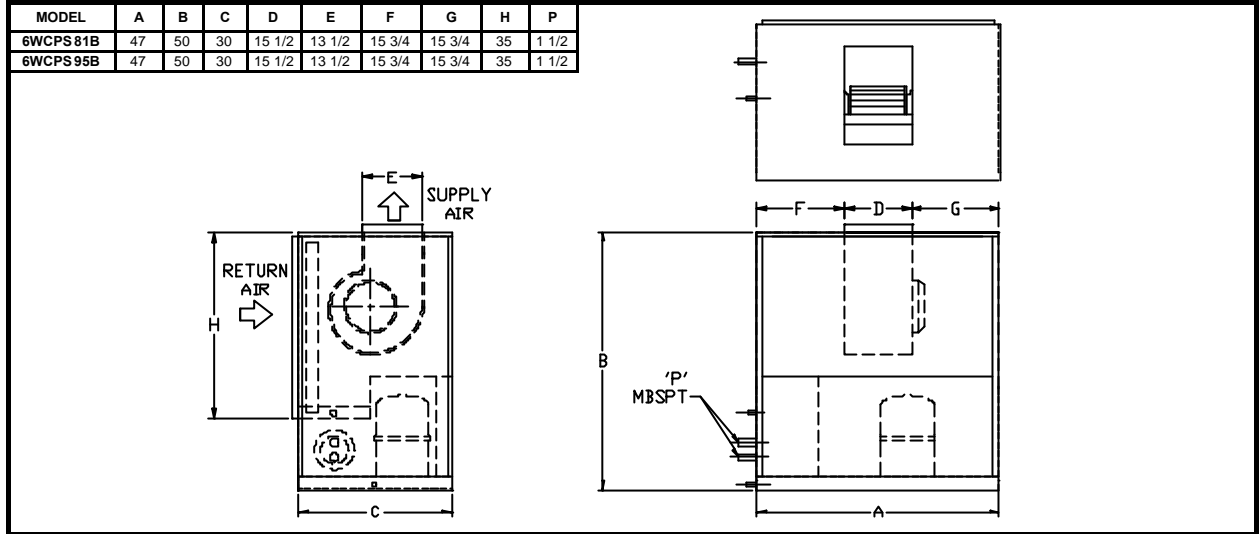

## 6WCPS 108B, 145B, 160B

MODEL	A	B	C	D	E	F	G	H	P
6WCPS 108B	58 1/2	63	30	15 1/2	13 1/2	21 1/2	21 1/2	42	1 1/2
6WCPS 145B	58 1/2	63	30	15 1/2	13 1/2	21 1/2	21 1/2	42	1 1/2
6WCPS 160B	58 1/2	63	30	15 1/2	13 1/2	21 1/2	21 1/2	42	1 1/2

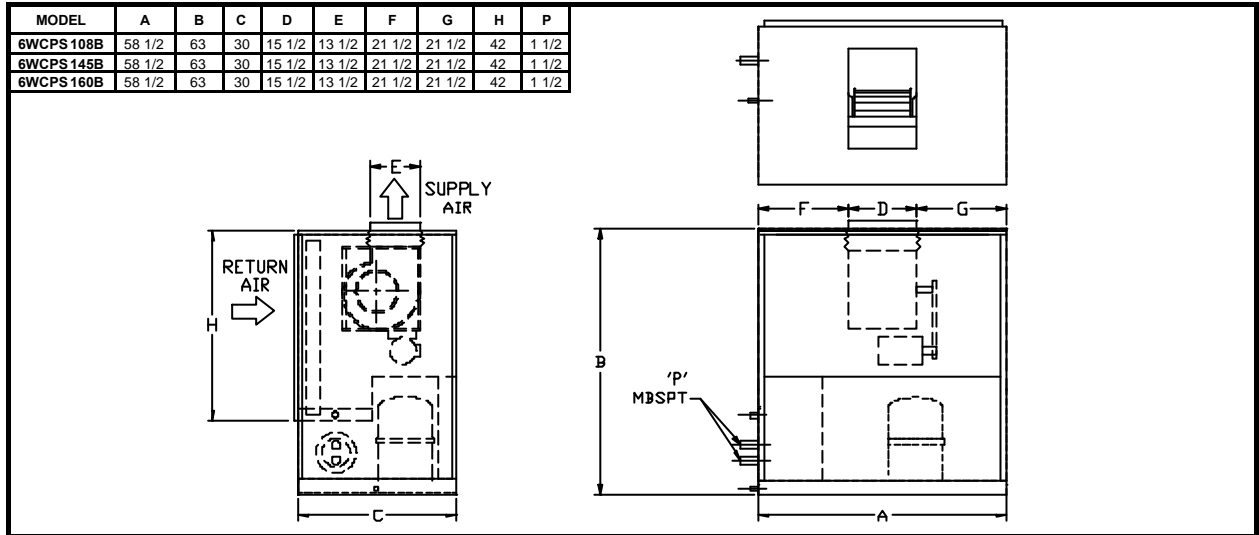

## 6WCPS 190B, 220B, 250B

MODEL	A	B	C	D	E	F	G	H	P	Q
6WCPS 190B	76	62	38	18 1/2	16	28 3/4	28 3/4	38	2	-
6WCPS 220B	76	62	38	18 1/2	16	28 3/4	28 3/4	38	2	-
6WCPS 250B	76	62	38	18 1/2	16	28 3/4	28 3/4	38	1 1/2	1 1/2

Note: Number of compressor & condenser to refer to physical data .

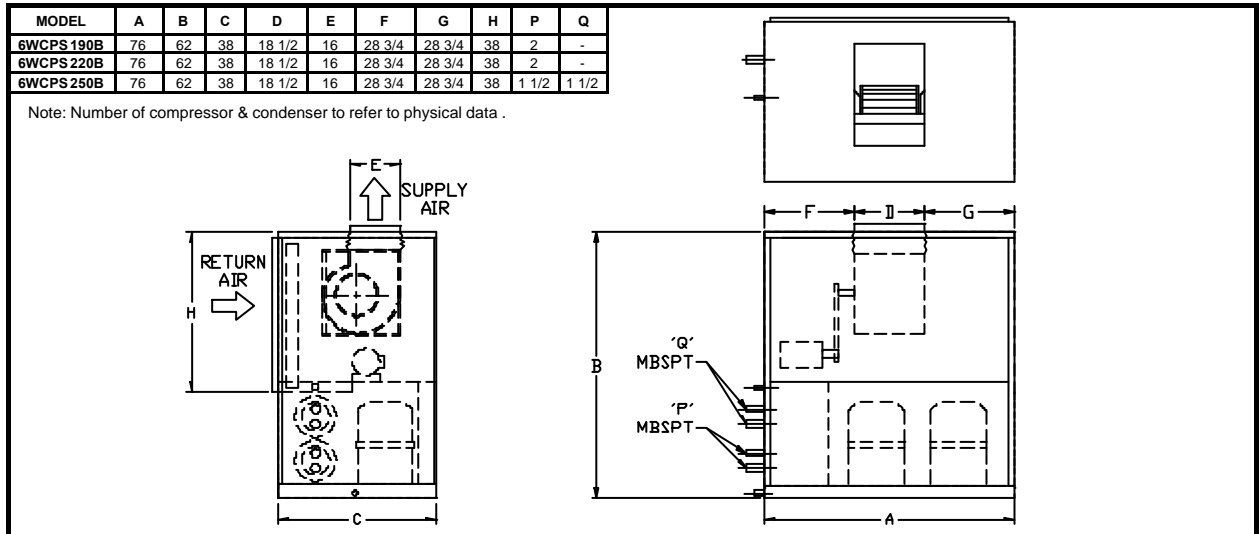

NOTE: ALL DIMENSIONAL ARE IN INCHES.



# DIMENSIONAL DATA

## 6WCPS 285B, 320B, 380B

MODEL	A	B	C	D	E	F	G	H	P	Q
6WCPS 285B	76	68	41 1/2	17	19	30	29	47	1 1/2	1 1/2
6WCPS 320B	76	68	41 1/2	17	19	30	29	47	1 1/2	1 1/2
6WCPS 380B	76	68	41 1/2	22	19	30	24	47	2	2

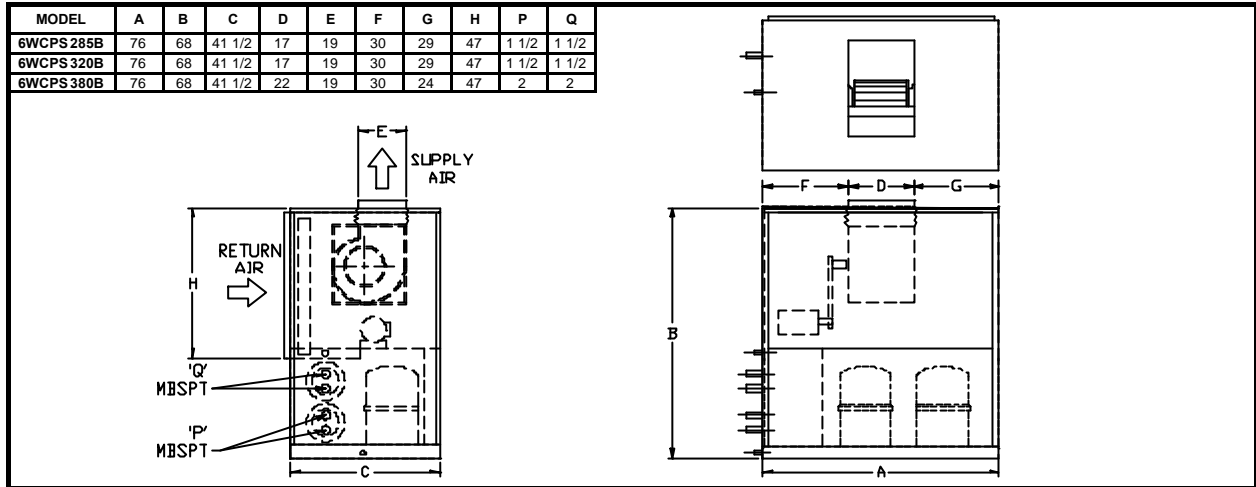

## 6WCPS 445B, 480B, 510B, 570B & 6WCPR 540B

MODEL	A	B	C	D	E	F	G	H	P	Q
6WCPS 445B	84	78	52	22	19	30	32	62	2	1 1/2
6WCPS 480B	84	78	52	25 1/4	25 1/4	30	28 3/4	62	2 1/2	1 1/2
6WCPS 510B	84	78	52	28 1/4	28 1/4	30	25 3/4	62	2 1/2	2
6WCPS 570B	84	78	52	28 1/4	28 1/4	30	25 3/4	62	2 1/2	2
6WCPR 540B	84	78	52	28 1/4	28 1/4	30	25 3/4	62	2	2

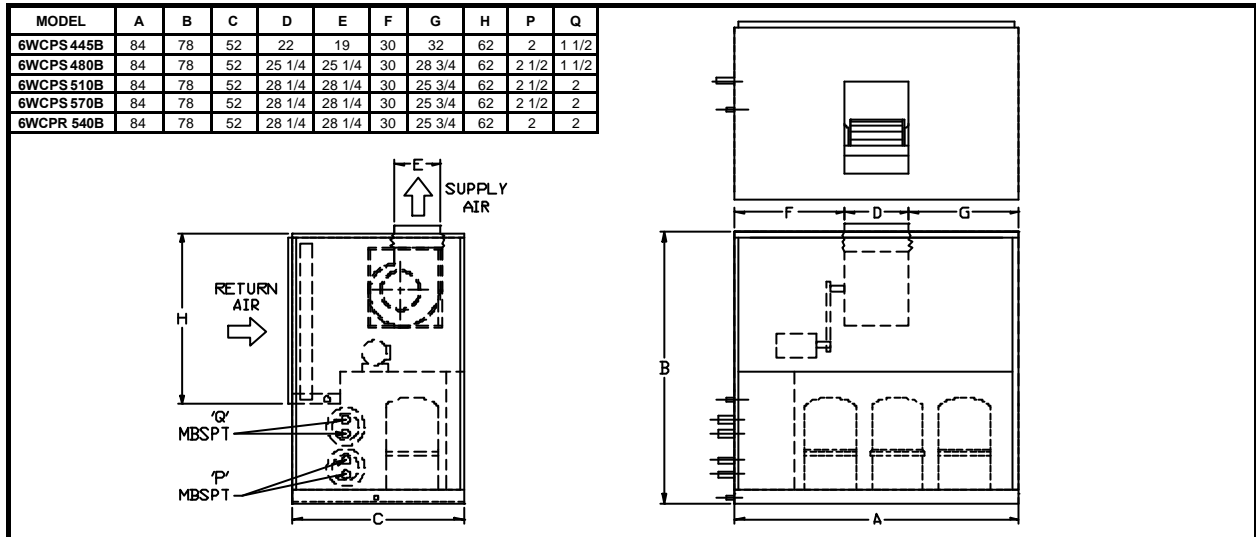

## 6WCPS 640B, 700B, 760B & 6WCPR 640B

MODEL	A	B	C	D	E	F	G	P	Q	R
6WCPS 640B	90	84	64	28 1/4	28 1/4	34	27 3/4	2	2	2
6WCPS 700B	90	84	64	28 1/4	28 1/4	34	27 3/4	2 1/2	2 1/2	-
6WCPS 760B	90	84	64	31 1/2	31 1/2	34	24 1/2	2 1/2	2	2
6WCPR 640B	90	84	64	28 1/4	28 1/4	34	27 3/4	2 1/2	2 1/2	-

Note: Number of compressor & condenser to refer to physical data.

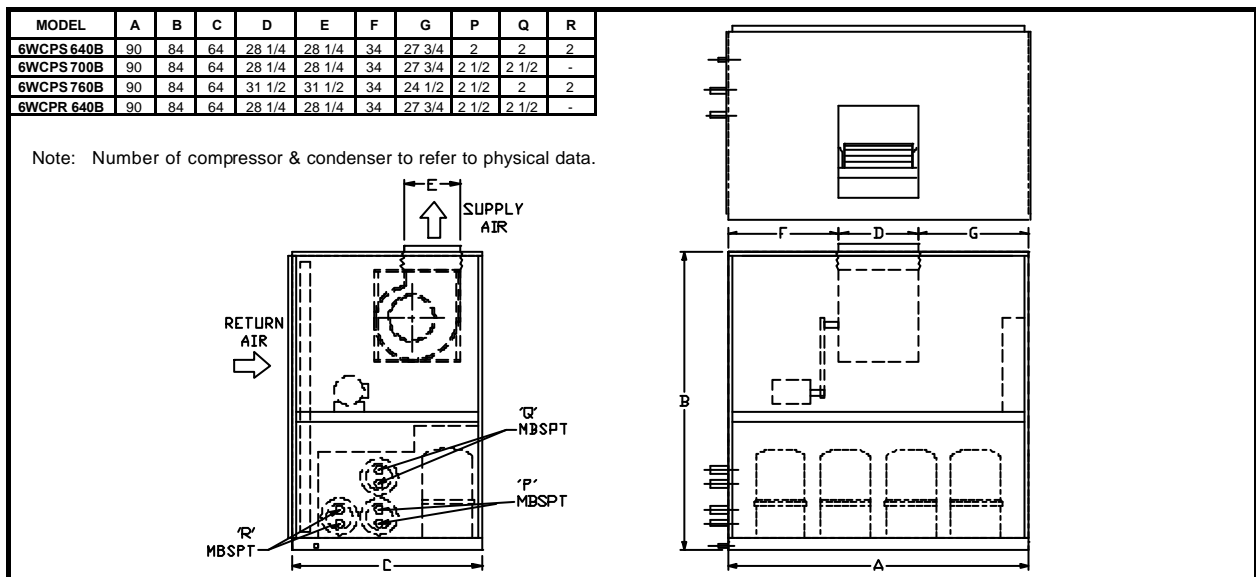

NOTE: ALL DIMENSIONAL ARE IN INCHES.

# DIMENSIONAL DATA

## 6WCPS 800B, 860B, 950B & 6WCPR 810B, 960B, 1080B

MODEL	A	B	C	D	E	F	G	P	Q	R	S
6WCPS 800B	108	92	72	31 1/2	31 1/2	38 1/4	38 1/4	2 1/2	2 1/2	-	-
6WCPS 860B	108	92	72	35 1/2	35 1/2	38 1/4	34 1/4	2	2	2 1/2	-
6WCPS 950B	108	92	72	35 1/2	35 1/2	38 1/4	34 1/4	2 1/2	2 1/2	2	-
6WCPR 810B	108	92	72	31 1/2	31 1/2	38 1/4	38 1/4	2	2	2	-
6WCPR 960B	108	92	72	35 1/2	35 1/2	38 1/4	34 1/4	2 1/2	2 1/2	2 1/2	-
6WCPR 1080B	108	92	72	35 1/2	35 1/2	38 1/4	34 1/4	2	2	2	2

Note: Number of compressor & condenser to refer to physical data.

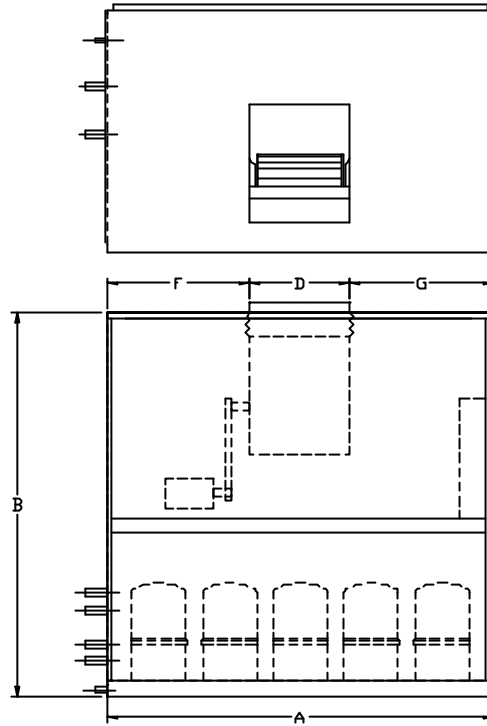
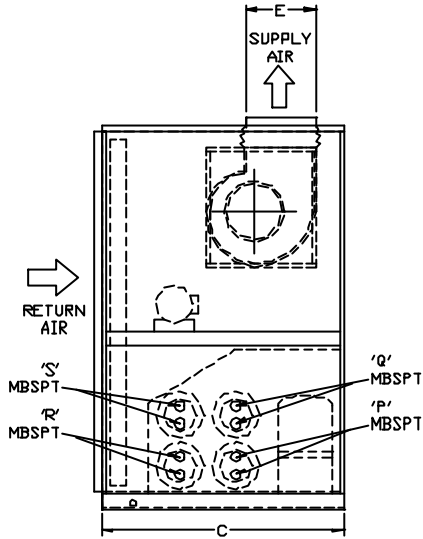

## 6WCPS 1140B, 1340B, 1520B & 6WCPR 1180B, 1280B

MODEL	A	B	C	D1	D2	E	F	G	P	Q	R	S
6WCPS 1140B	142	100	86	28 1/4	28 1/4	28 1/8	42	21 1/2	2 1/2	2 1/2	2 1/2	-
6WCPS 1340B	142	100	86	28 1/4	28 1/4	28 1/8	42	21 1/2	2 1/2	2 1/2	2 1/2	2 1/2
6WCPS 1520B	142	100	86	28 1/4	28 1/4	28 1/8	42	21 1/2	2 1/2	2 1/2	2 1/2	2 1/2
6WCPR 1180B	142	100	86	28 1/4	28 1/4	28 1/8	42	21 1/2	2 1/2	2 1/2	2	2
6WCPR 1280B	142	100	86	28 1/4	28 1/4	28 1/8	42	21 1/2	2 1/2	2 1/2	2 1/2	2 1/2

Note: Number of compressor & condenser to refer to physical data.

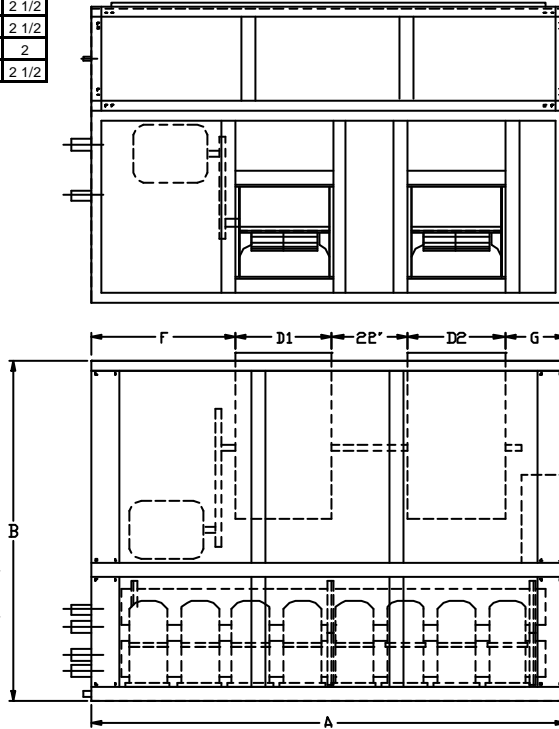
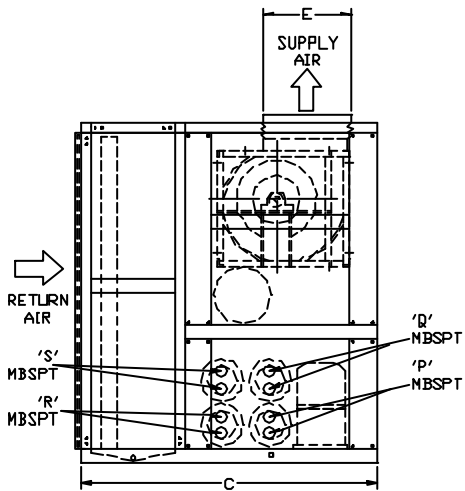

NOTE: ALL DIMENSIONAL ARE IN INCHES.

# PHYSICAL DATA

MODEL	COMPRESSOR				COND.		BLOWER SECTION					EVAPORATOR COIL		FILTERS CHARGE		R-22	APPROX. OPERATING WEIGHT (LBS)	
	QTY	MCC EA.	LRA EA.	NRA EA.	QTY	MIN-MAX USGPM	BLOWER		MOTOR			FAN CFM	ROWS DEEP	TOTAL FACE AREA (FT <sup>2</sup> )	QTY	SIZE (INCH)		QTY x LBS COMP.
							QTY	DIA x WIDTH (INCH)	MAX HP	FLA	LRA							
6WCPS 81B	1	1x14.0	1x74.0	1x7.4	1	8 29	1	12x12	1.0	-	-	-	3	5.0	4	16x16	1x9.9	762
6WCPS 95B	1	1x17.0	1x101.0	1x9.6	1	9 33	1	12x12	1.0	-	-	-	3	5.8	4	16x16	1x12.3	840
6WCPS 108B	1	1x23.0	1x95.0	1x10.7	1	13 44	1	12x12	4.0	5.4	28.8	2250 4125	3	7.5	4	16x20	1x17.6	1350
6WCPS 145B	1	1x26.9	1x125.0	1x13.9	1	15 51	1	12x12	4.0	5.4	28.8	2380 4355	4	7.9	4	16x20	1x16.0	1368
6WCPS 160B	1	1x27.5	1x125.0	1x15.8	1	16 56	1	12x12	4.0	5.4	28.8	2380 4355	4	7.9	4	16x20	1x23.8	1397
6WCPS 190B	1	1x34.0	1x167.0	1x16.0	1	19 67	1	15x15	7.5	9.3	60.0	3970 7270	3	13.2	2 4	16x20 16x25	1x25.3	1750
6WCPS 220B	2	1x37.0	1x198.0	1x20.0	1	22 76	1	15x15	7.5	9.3	60.0	4600 8440	3	15.4	2 4	16x20 16x25	1x13.3 1x17.6	1880
6WCPS 250B	2	1x23.0 1x26.9	1x95.0 1x125.0	1x10.7 1x13.9	2	25 88	1	15x15	7.5	9.3	60.0	4960 9090	3	16.5	1 2 1 2	16x20 16x25 20x20 20x25	2x17.6	1980
6WCPS 285B	2	2x26.9	2x125.0	2x13.9	2	29 100	1	18x13	15.0	17.8	111.0	6020 11040	3	20.1	2 1 2	20x25 20x20 25x25	1x17.6 1x23.8	2375
6WCPS 320B	2	2x27.5	2x125.0	2x15.8	2	32 112	1	18x13	15.0	17.8	111.0	6375 11690	3	21.3	2 1 2	20x25 20x20 25x25	2x23.8	2700
6WCPS 380B	2	2x34.0	2x167.0	2x16.0	2	38 133	1	18x18	15.0	17.8	111.0	6375 11690	4	21.3	2 1 2	20x25 20x20 25x25	2x25.3	3150
6WCPS 445B	3	2x26.9 1x27.5	2x125.0 1x125.0	2x13.9 1x15.8	2	45 156	1	18x18	20.0	23.7	144.0	7080 13000	4	23.6	6	25x25	1x17.6 2x23.8	3372
6WCPS 480B	3	3x27.5	3x125.0	3x15.8	2	48 168	1	20x20	20.0	23.7	144.0	9000 16500	3	30	9	20x25	3x23.8	4264
6WCPS 510	3	1x34.0 2x27.5	1x167.0 2x125.0	1x16.0 2x15.8	2	51 178	1	22x22	20.0	23.7	144.0	9000 16500	3	30	9	20x25	2x23.8 1x25.3	4264
6WCPR 540B	2	2x49	2x141	2x26.7	2	54 189	1	22x22	20.0	23.7	144.0	9000 16500	4	30	9	20x25	2x29.5	4200
6WCPS 570B	3	3x34.0	3x167.0	3x16.0	2	57 200	1	22x22	20.0	23.7	144.0	9000 16500	4	30	9	20x25	3x25.3	4640
6WCPS 640B	3	3x37.0	3x198.0	3x20.0	3	64 224	1	22x22	30.0	34.8	211.0	10800 19800	4	36	12	20x25	4x23.8	6260
6WCPR 640B	2	2x56	2x180	2x32.7	2	64 224	1	22x22	30.0	34.8	211.0	10800 19800	4	36	12	20x25	2x35.0	6200
6WCPS 700B	4	4x34.0	4x167.0	4x16.0	2	70 245	1	22x22	30.0	34.8	211.0	11500 21200	4	48.6	12	20x25	2x23.8 2x25.3	6300
6WCPS 760B	4	2x37.0 2x34.0	2x198.0 2x167.0	2x20.0 2x16.0	3	76 266	1	22x22	30.0	34.8	211.0	12200 32340	4	40.6	12	20x25	4x25.3	6521
6WCPS 800B	4	4x37.0	4x198.0	4x20.0	2	80 280	1	25x25	40.0	47.1	291.0	16150 29620	3	53.9	4 4 8	16x25 20x25 25x25	5x23.8	6972
6WCPR 810B	3	3x49	3x141	3x26.7	3	80 280	1	25x25	40.0	47.1	291.0	16150 29620	3	53.9	4 4 8	16x25 20x25 25x25	3x29.5	6800
6WCPS 860B	6	2x34.0 4x26.9	2x167.0 4x125.0	2x16.0 4x13.9	3	89 312	1	28x28	40.0	47.1	291.0	16150 29620	3	53.9	4 4 8	16x25 20x25 25x25	3x23.8 2x25.3	7480
6WCPS 950B	6	4x34.0 2x26.9	4x167.0 2x125.0	4x16.0 2x13.9	3	96 336	1	28x28	40.0	47.1	291.0	16150 29620	4	53.9	4 4 8	16x25 20x25 25x25	5x25.3	7750
6WCPR 960B	3	3x56	3x180	3x32.7	3	96 336	1	28x28	40.0	47.1	291.0	16150 29620	4	53.9	4 4 8	16x25 20x25 25x25	3x35.0	7200
6WCPR 1080B	4	4x49	4x141	4x26.7	4	108 378	1	28x28	40.0	47.1	291.0	16150 29620	4	53.9	4 4 8	16x25 20x25 25x25	4x29.5	8000
6WCPS 1140B	6	2x37.0 4x34.0	2x198.0 4x167.0	2x20.0 4x16.0	3	114 399	2	22x22	50.0	58.5	363.0	20000 36770	4	66.8	2 9 9	20x20 20x25 25x25	6x25.3	8790
6WCPR 1180B	4	2x56 2x49	2x180 2x141	2x32.7 2x26.7	3	118 413	2	22x22	50.0	58.5	363.0	20000 36770	4	66.8	2 9 9	20x20 20x25 25x25	2x29.5 2x35.0	8800
6WCPR 1280B	4	4x56	4x180	4x32.7	4	128 448	2	22x22	50.0	58.5	363.0	21200 38870	4	70.7	2 9 9	20x20 20x25 25x25	4x35.0	9200
6WCPS 1340B	8	4x34.0 4x27.5	4x167.0 4x125.0	4x16.0 4x15.8	4	134 469	2	22x22	50.0	58.5	363.0	21200 38870	4	70.7	2 9 9	20x20 20x25 25x25	6x23.8 2x25.3	9122
6WCPS 1520B	8	4x37.0 4x34.0	4x198.0 4x167.0	4x20.0 4x16.0	4	152 532	2	22x22	50.0	58.5	363.0	21200 38870	5	70.7	2 9 9	20x20 20x25 25x25	8x25.3	9240

\* Condenser type: Cleanable shell and tubes.

- Notes:**
- 1.) LRA = Locked rotor ampere.
  - 2.) NRA = Nominal running ampere.
  - 3.) MCC = Maximum continuous current.
  - 4.) FLA = Full load ampere.
  - 5.) Power supply is 460V-3-60Hz except the blower motor for 6WCPR 81B to 6 WCPS 95B which is 230V-1ph-60Hz.
  - 6.) Minimum-maximum voltage is 460V ± 6%.
  - 7.) For other power supply requirements, please contact the Dunham-Bush sales office.
  - 8.) Blower for model WCPS 81B to 95B as direct driven.
  - 9.) Filter is one inch thick.

# ELECTRICAL

## TYPICAL WIRING DIAGRAM

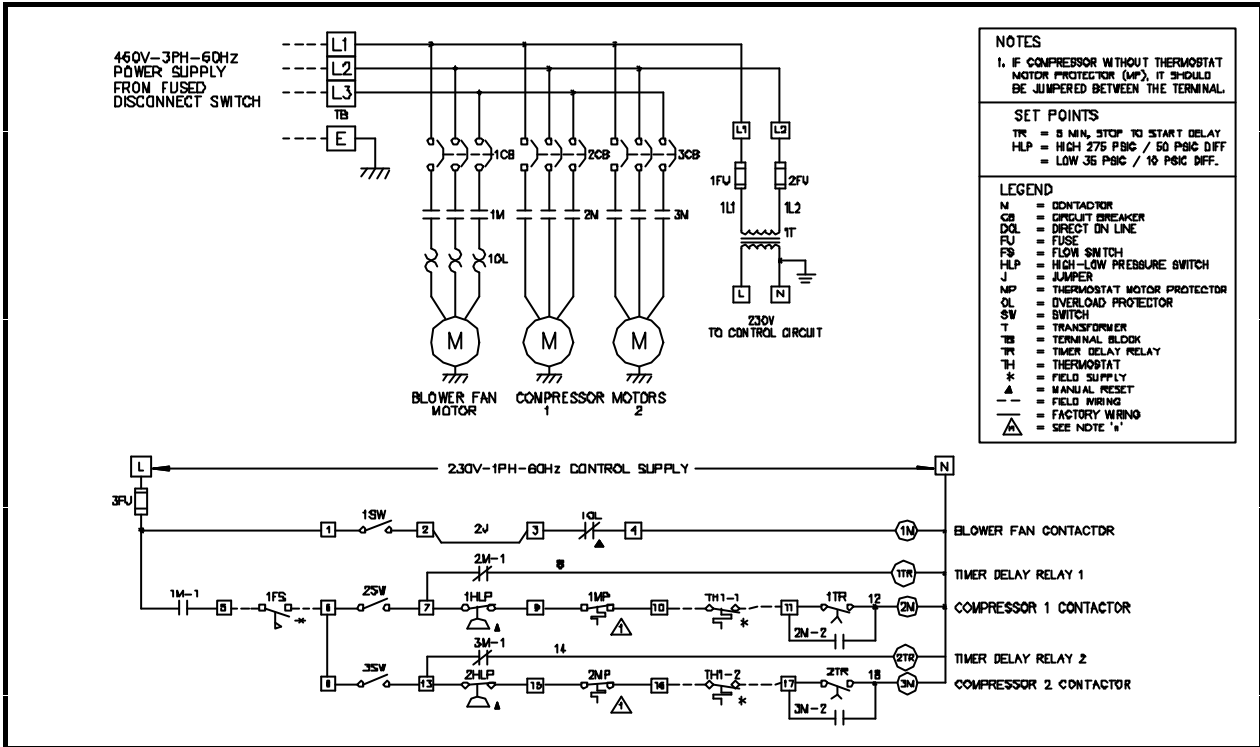

## CORRECTION FACTORS

To correct for variation in air flow, use this multiplier.

AIR FLOW VARIATION	TOTAL CAPACITY	SENSIBLE CAPACITY
0.8	0.960	0.900
0.9	0.980	0.950
1.0	1.000	1.000
1.1	1.015	1.045
1.2	1.025	1.090

To correct for altitude, use this multiplier.

ALTITUDE ABOVE SEA LEVEL - FT	COOLING CAPACITY
0	1.00
2000	0.98
3000	0.97
4000	0.96
5000	0.95
6000	0.93
7000	0.92

To correct sensible capacity for varying dry bulb.

DRY BULB	WET BULB			
	57	62	67	72
75	0.84	0.81	0.78	0.74
80	1.00	1.00	1.00	1.00
85	1.16	1.18	1.21	1.26

NOTE: IF THE CAPACITY AFTER MULTIPLYING THE SENSIBLE WITH THE CORRECTION FACTOR EXCEED THE TOTAL CAPACITY, THEN THE SENSIBLE MUST BE EQUAL TO THE TOTAL.

MANUFACTURER RESERVES THE RIGHT TO CHANGE SPECIFICATION OR DESIGNAT ANY TIME WITHOUT PRIOR NOTICE.

**DUNHAM-BUSH**<sup>®</sup>  
 Products That Perform...By People Who Care