



**Packaged Domestic Hot Water Generator  
with Brazed-Plate, Double-Wall Heat Exchanger and Storage Tank  
Energy Source: Boiler Water**



No tank linings.  
No anodes required.



**AquaPLEX® Duplex Stainless Steel Tank with 15-year Full Corrosion Warranty  
and 10 Additional Years of Discounted Replacement**

Up to 6,000,000 Btuh Output  
100% Redundant Heat Exchanger Designs Available  
150 to 400 Gallon Storage Tanks  
Double-wall Brazed Plate Heat Exchangers  
Domestic Water Temperature to 180°F  
Skid-mounted with Factory Pre-assembled Piping

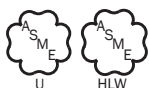

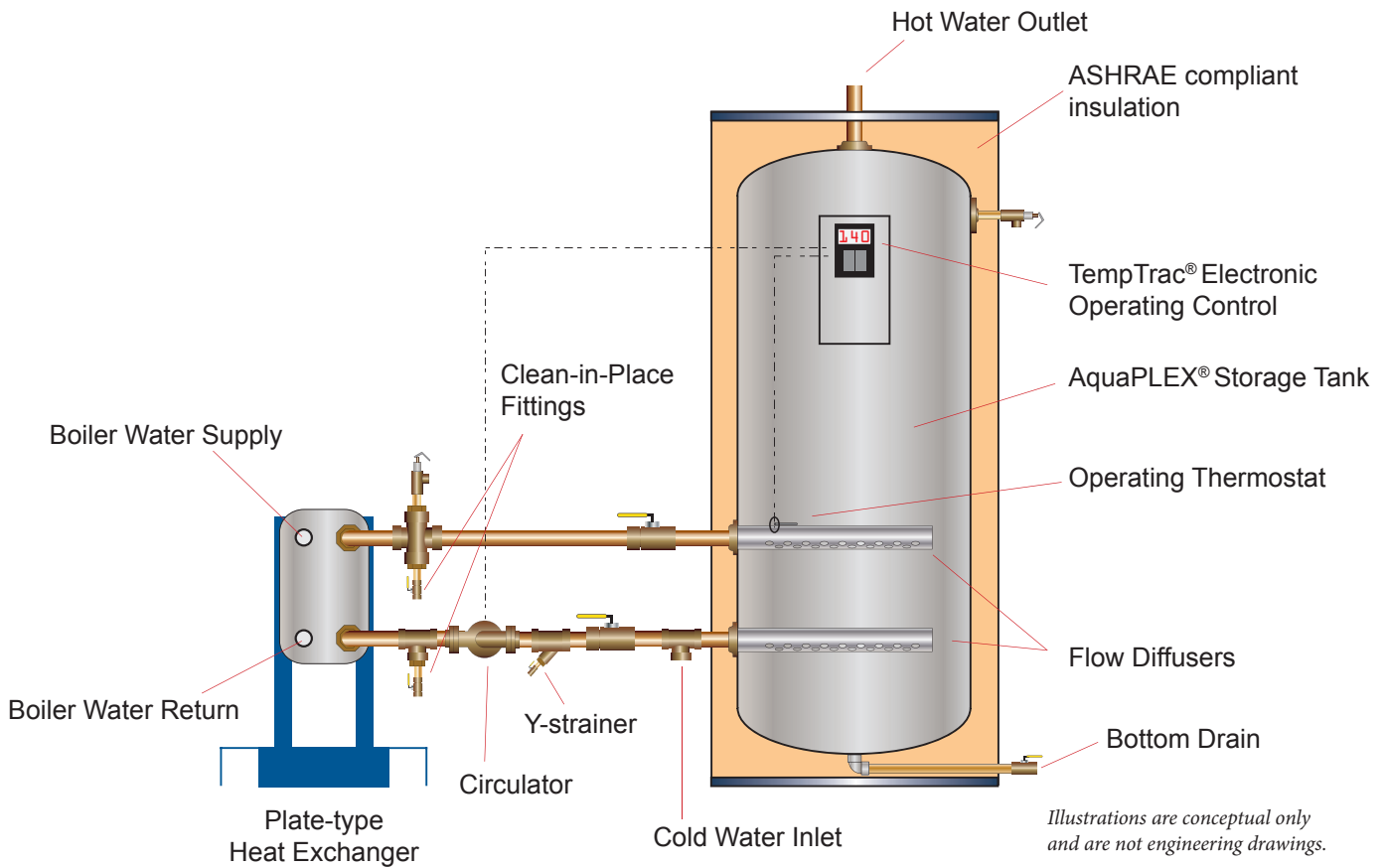

### Heat Transfer Characteristics of Plate Heat Exchangers

Due to their unique heat transfer characteristics, plate heat exchangers excel when applied in low-temperature boiler water loops. A plate exchanger, when supplied with 145°F boiler water, can produce 140°F domestic hot water while reducing boiler water return temperature to 100°F or lower. This is highly beneficial in condensing boiler systems where efficiency improves with reductions in both supply and return water temperature.

By comparison, u-tube heat exchangers are typically sized for a 20°F difference between the entering boiler water temperature and the desired domestic hot water outlet temperature. In addition, the boiler return water cannot be lower than the domestic hot water outlet temperature. For example, to produce 140°F domestic hot water, a u-tube exchanger would require 160°F entering boiler water and return boiler water would be no less than 141°F; temperatures above the ideal range for condensing boilers.

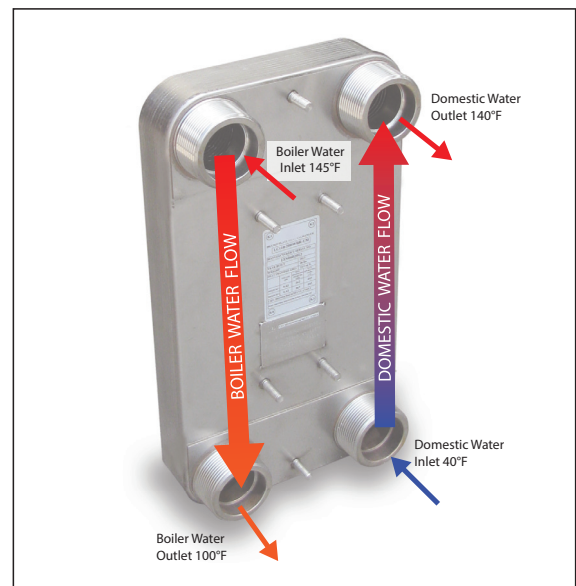

*Inside the plate exchanger, counter-flows of boiler and domestic water maximize the temperature differentials and allow the temperatures of the opposing liquids to “cross” with boiler return water becoming colder than domestic outlet water.*

## Sequence of Operation

Demand for hot water causes a temperature drop in the storage tank as cold makeup water displaces the hot water in the tank. The tank thermostat senses this temperature drop and signals the operator to energize the circulator. Cold domestic water flows through the heat exchanger, captures heat from the boiler water and returns to the storage tank. Flow diffusers reduce the velocity of water leaving and returning to the storage tank from the heat exchanger. This eliminates turbulence in the storage tank and preserves the natural temperature stratification, allowing delivery of 80% of the storage tank's capacity at the desired set point temperature.

When tank temperature returns to the desired set point, the circulator is de-energized. If the installation includes an optional boiler water control valve, the electronic operator will energize and de-energize the valve.

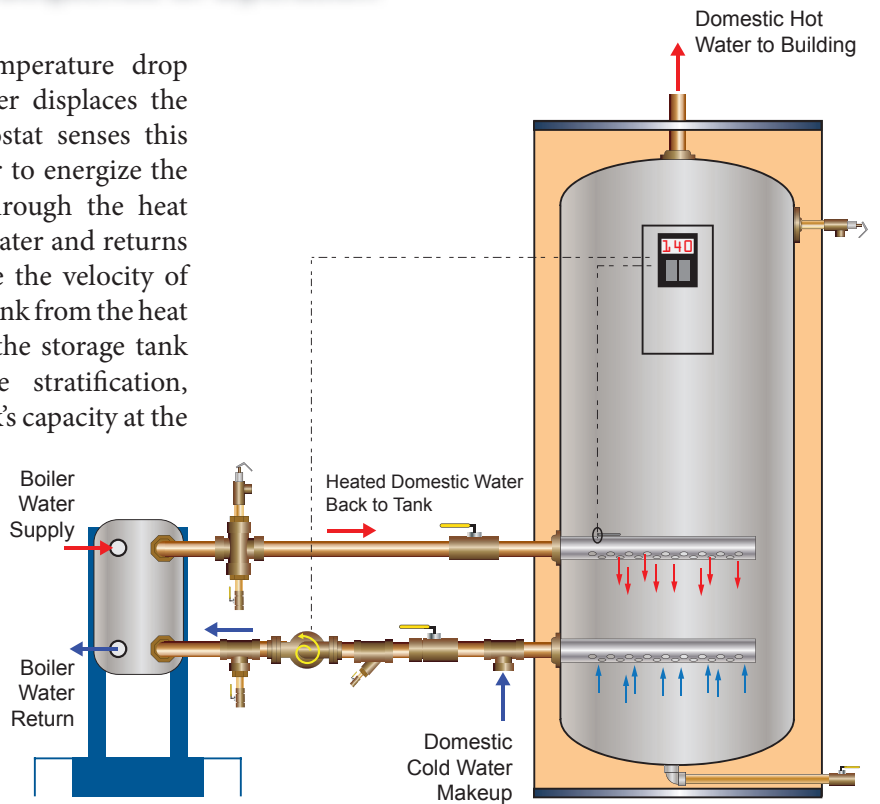

## Boiler Water Control Options

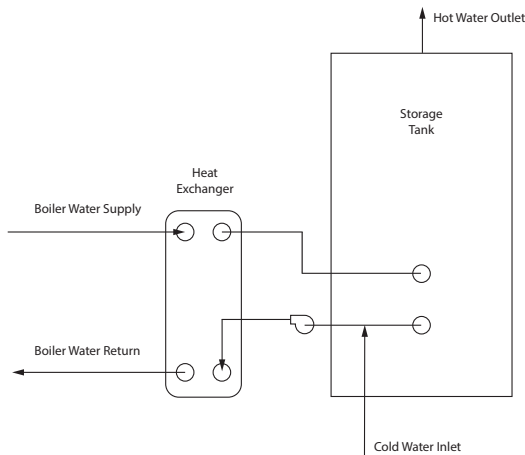

### No Boiler Water Control Valve Needed

Constant boiler water flow through the heat exchanger is acceptable because heat transfer to the domestic water is controlled entirely by the circulator between the tank and heat exchanger. Constant flow at the water heater is also a logical choice for boiler loops equipped with VFD pump controls because domestic hot water is a year-round requirement in continual need of boiler water flow.

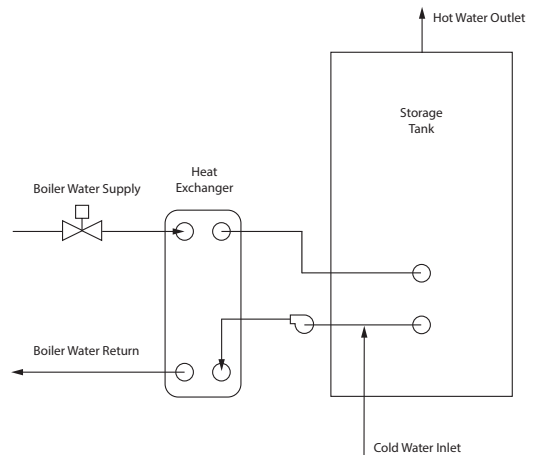

### 2-Way Boiler Water Control Valve

If the water heater is not utilized as the constant flow bypass in a VFD-equipped boiler loop and boiler flow is to be allowed only during a domestic water call for heat, the plate heat exchanger can be equipped with a motorized 2-way valve. In this configuration, the boiler water 2-way valve and the circulator are controlled by the TempTrac operator.



**AquaPLEX® Storage Tank (unlined duplex alloy)  
with EZ PLATE® Boiler Water Heat Exchanger - Double-wall**

**Standard Equipment**

- 316 stainless steel, double-wall heat, copper-brazed heat exchangers with ASME safety relief valve
- ASME-stamped Section VIII for 362 psi and 445°F
- 2-1/2" NPT connections
- Factory assembled exchanger to tank piping with clean-in-place fittings, bronze y-strainer, bronze pump and all copper and bronze fittings. (Pro-press)
- AquaPLEX storage tank
- ASME stamped HLW for 150 psi
- ASME-rated temperature and pressure relief valve
- Programmable electronic operating control with digital temperature readouts (BAS connectable via Modbus RTU)
- High temperature limit
- Bottom drain valve

**Optional Equipment**

- 2-way boiler water control valve
- Up to 250 psi storage tanks (consult PVI representative)

**Model Prefixes and Recoveries**

Gallon per Hour 40°F to 140°F with 150°F boiler water			
Single heat exchanger models		Dual heat exchanger models (100% redundancy)	
Model Prefix	gph	Model Prefix	gph
600	353	600-2	706
900	530	900-2	1060
1200	706	1200-2	1412
1800	1059	1800-2	2118
2400	1412	2400-2	2824
3000	1765	3000-2	3530
3600	2118	3600-2	4236
4500	2648	4500-2	5396
5400	3177	5400-2	6354

**Storage Tank Sizes**

150 • 175 • 215 • 250 • 300 • 400 gallons

For larger vertical and horizontal storage tanks, consult PVI representative.

