

# JSBLF Series

## Compact, High Purity Low Flow Back Pressure Regulating Valve

The JSBLF is a fully drainable compact back pressure regulator designed and built specifically for hygienic, ASME BPE low flow gas and liquid applications.

- It's been designed specifically to eliminate all threaded connections and contaminant traps below the diaphragm.
- It is completely drainable (an industry first in compact hygienic regulator design), and compatible with CIP and SIP practices. See drainability guideline on page 6.
- The simple trim design facilitates quick trim change out and cleaning without valve removal or complete disassembly.

The durable valve body and metal trim components are machined from ASTM A479 316L SST barstock with wetted components and finished to ASME BPE SF5 (20Ra micro-inch (0,5 Ra  $\mu\text{m}$ ), electropolished) as standard. The valve is outfitted with the rugged Jorlon diaphragm and TFM or PEEK seats, all FDA approved, USP Class VI compliant materials. These materials of construction enable the JSBLF to withstand the rigors of continuous SIP and CIP processes if required.

### FEATURES

- Fully drainable with no threaded connections, or contaminant traps below the diaphragm
- In-line removable trim significantly reduces maintenance time
- Barstock construction guarantees material integrity and surface finish
- Minimized internal volume
- Proprietary Jorlon diaphragm material provides exceptionally long life and CIP/SIP capability, and FDA and USP Class VI compliance and is warrantied for life.
- Soft seat material for ANSI Class VI shutoff

### DOCUMENTATION

The following documentation is shipped at no charge:

- Steriflow Unicert, a QC signed Certificate of Compliance for:
  - Material, listing heat numbers with attached MTR's
  - Surface Finish
  - FDA/USP Class VI - for all thermoplastic and elastomers
- Traceability:
  - Each individual product serial number is traceable to the Unicert serial number, heat numbers and attached MTR's

Other documents must be requested at time of RFQ, or order:

- ADI/TSE Free, Certified Test reports, Certificate of Origin.



### APPLICATIONS

#### Clean Compressed Air and Gas

Typically used in Biopharm or parenteral installations for modulating pressure relief during vessel filling, or for continuous sparge or blanket gas venting.

#### WFI, Buffer, Process Liquids

Ideal for use in compact, low flow liquid back pressure applications in buffer dilution, pump head pressure control, and for DP maintenance across filter membranes or chromatography columns.

## SPECIFICATIONS

**Sizes:** 3/8" (DN10), 1/2" (DN15), 3/4" (DN20)

**Ends:** Tri-Clamp, Tube Weld End to ASME BPE, DIN or ISO dimensions as standard

**Soft Seat Materials for ANSI Class VI Shut-Off:**

- TFM to +450°F (232°C) FDA, USP Class VI
- PEEK to +350°F (177°C) FDA, USP Class VI

**Body and Wetted Component Material:**

- ASTM A479 316L SST (DIN 1.4404 as standard)
- DIN 1.4435, AL6XNTM and other materials upon request

**Diaphragm Material:** PTFE-based Jorlon; FDA, USP Class VI

**Maximum Inlet Pressure:** 150 psig (10,5 bar)

**Spring Ranges:** 5–50 psi (0,3–3,4 bar); 25–100 psi (1,7–6,9 bar); 50–150 psi (3,4–10,3 bar); 75–250 psi (5,2–17,2 bar); 100–450 psi (6,9–31 bar); 200–450 psi (13,8–31 bar)

**Optional Cleaning Specifications:**

- Clean for Oil-Free
- O2 Cleaning complying with ASTM G93-03 2011 and CGA G-4.1-2009

**Flow Characteristics Cv (Kv):**

- Cv 0.05 (0,04); for relief valve sizing is 0.15(0,13)
- Cv 0.15(0,13); for relief valve sizing is 0.25(0,21)
- Cv 0.25(0,21); for relief valve sizing is 0.35(0,30)
- Cv 0.35(0,30); for relief valve sizing is 0.45(0,39)

**Surface Finish:**

- Internal wetted components: ASME BPE SF5, 20 Ra  $\mu$ m, (0,5 Ra  $\mu$ m) electropolished
- External: 40 Ra  $\mu$ m (1,0 Ra  $\mu$ m) electropolished
- Other finishes optional

**Options:**

- Panel Mounting
- Captured Vent
- Inlet-Outlet Gauge

## OPTIONS

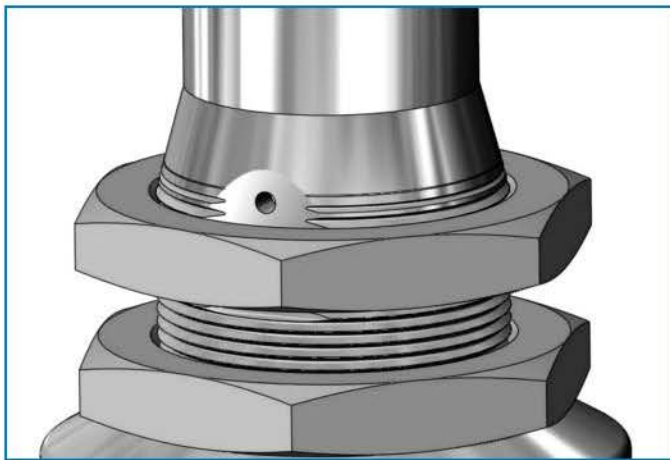

Panel Mount Option

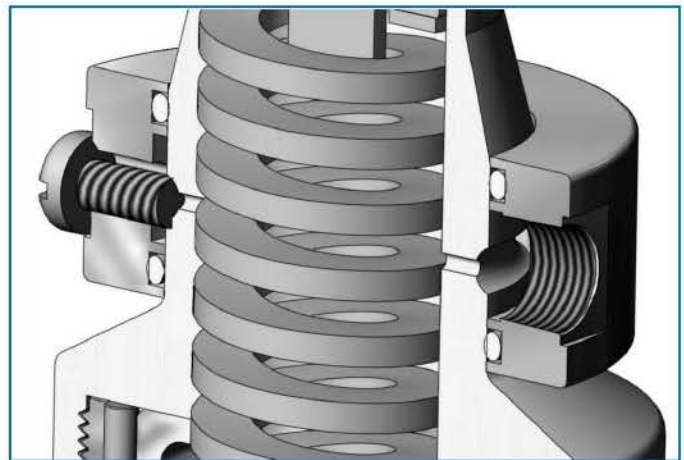

Captured Vent Option (1/8" NPT)

## OPTION DEFINITION

### Captured Vent

The captured vent design is for maximum safety for the user when handling toxic or hazardous media. It features a 1/8" FNPT port located on the spring housing. The user can easily tube this vent to a safe location.

### Panel Mount

The panel mount feature requires a panel cut out of 1-1/2" allowing insertion of the threaded spring housing, and a panel mount ring to secure the regulator against the panel.

## FEATURES & BENEFITS

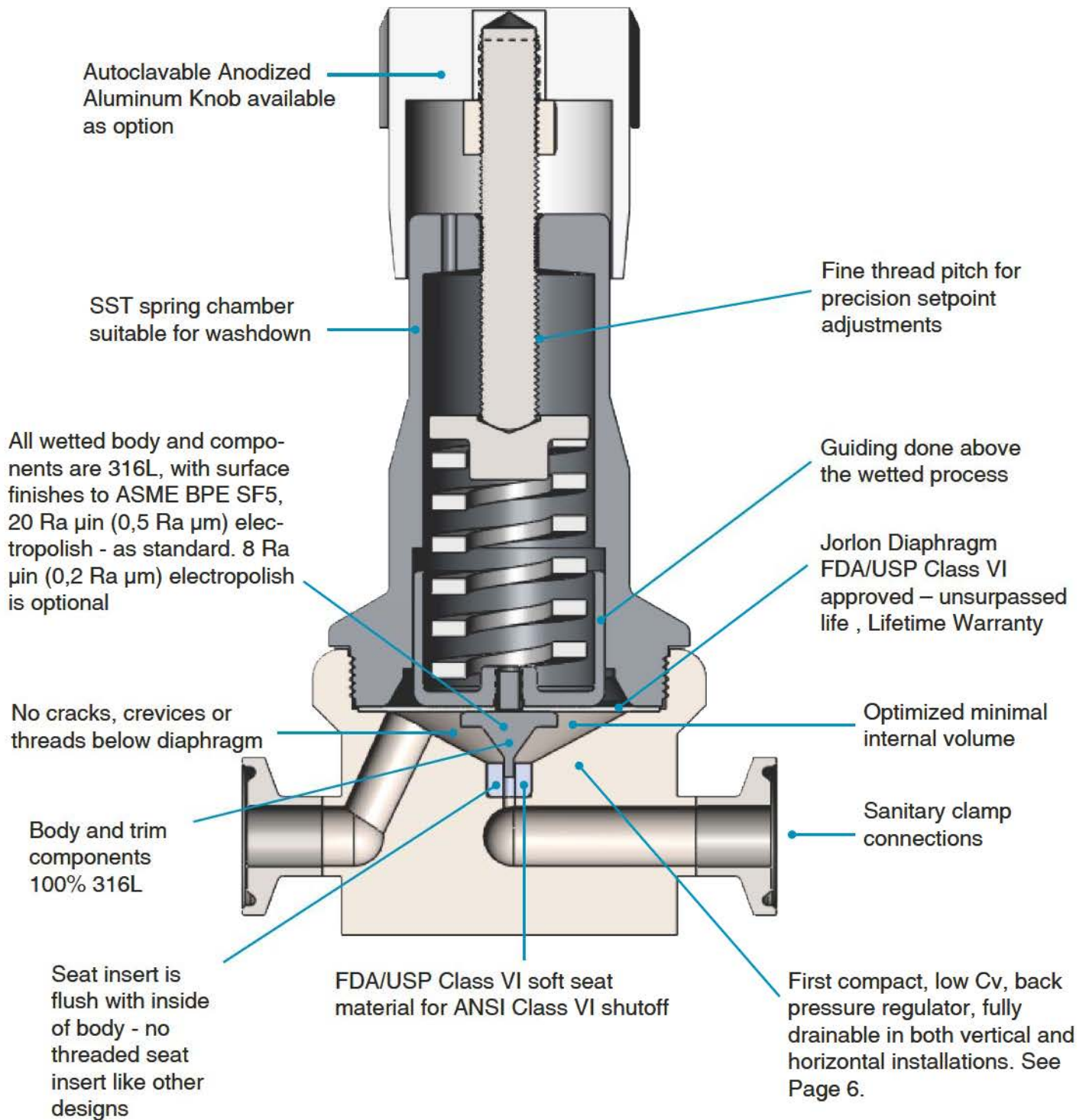

**Sizing**

**Clean Compressed Air & Gas:** Use the charts below to find the appropriate Cv for your valve. Or you may use the SFCV sizing program.

**Process Liquids, WFI, Buffer:** Use the sizing program for these applications.

**Sizing Program Instructions:**

1. Download the SFCV program. It can be found on our website home page at [www.steriflowvalve.com](http://www.steriflowvalve.com)
2. Use the software to find the appropriate CV for the customer's application conditions.
3. SFCV will tell you the CV needed to pass the required flow. Because the JSBLF works best under 50% capacity, you need to select a CV for the valve that is at least two times larger than the required Cv.

**Example:** Clean compressed air, at ambient temperature, P1 = 45 psi, P2 = 0 psi, ½" Tri-clamp Connections, flow rate 12 scfm. Using SFCV to size for CV we find that these conditions require an actual CV of 0.37. Calculating for less than 50% capacity we then multiply the result by 2x (0.37x 2 = 0.74). This means that we should choose the 0.8 CV trim to optimize the valve for the conditions.

**AIR FLOW AT VARIOUS INLET PRESSURE SET POINTS, USING DIFFERENT SPRING RANGES, WITH OUTLET PRESSURE AT 0 PSIG (0 BARG)**

**JSBLF PERFORMANCE WITH 0.05 Cv**

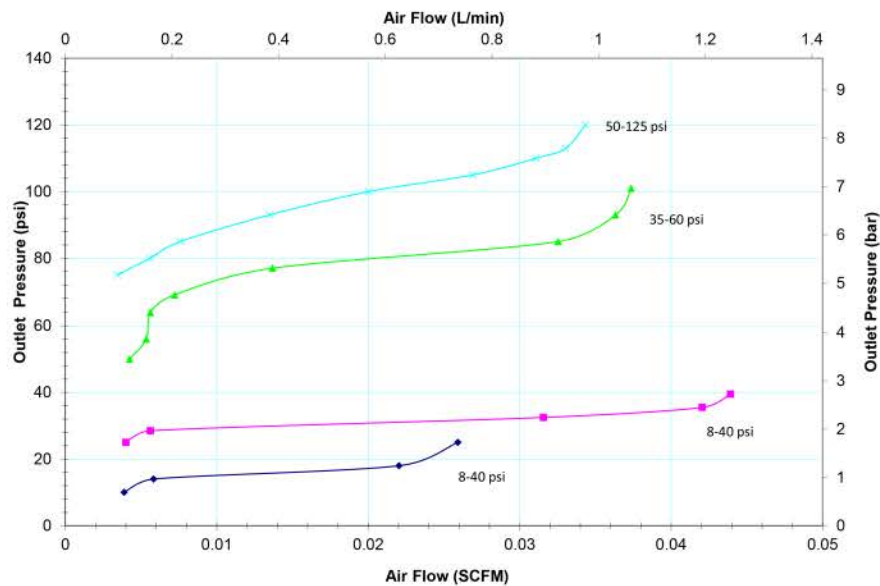

**JSBLF PERFORMANCE WITH 0.15 Cv**

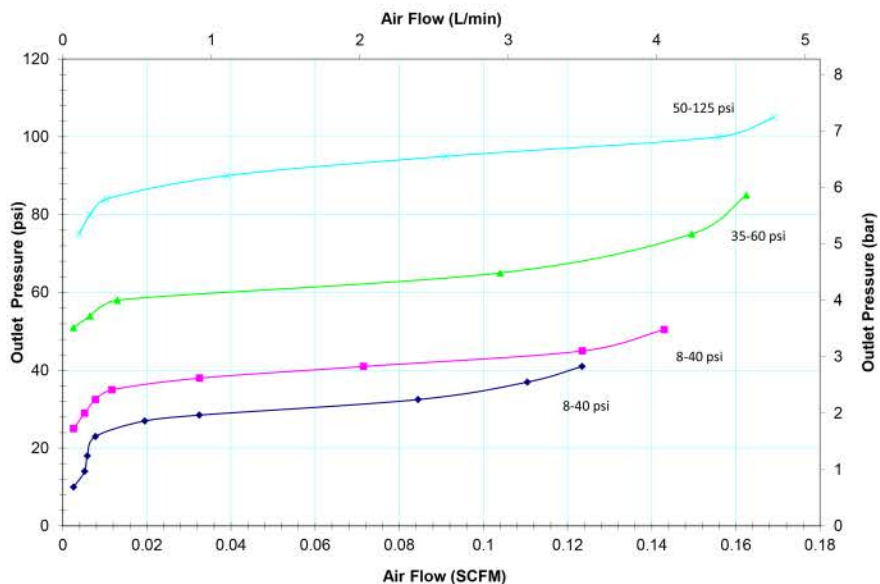

AIR FLOW AT VARIOUS INLET PRESSURE SET POINTS, USING DIFFERENT SPRING RANGES, WITH OUTLET PRESSURE AT 0 PSIG (0 BARG)

JSBLF PERFORMANCE WITH 0.25 Cv

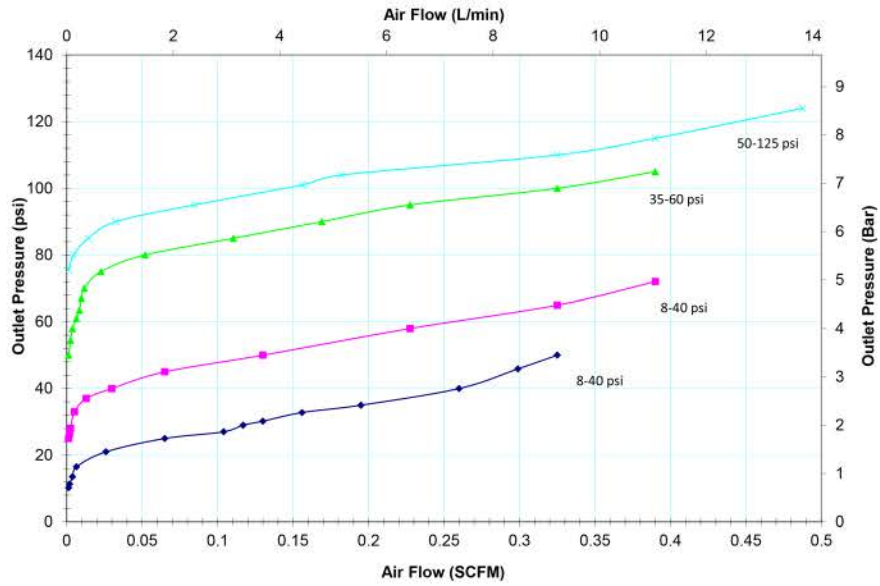

JSBLF PERFORMANCE WITH 0.35 Cv

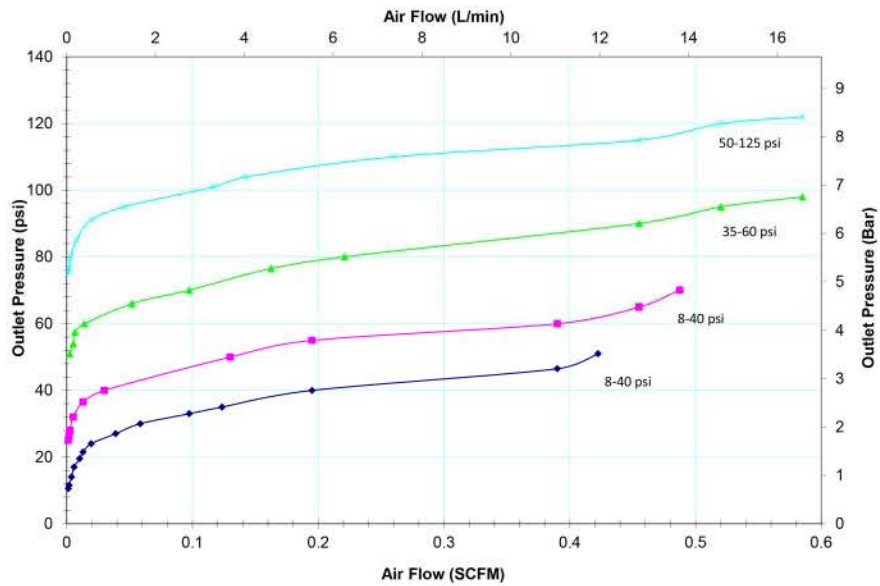

### ORIENTATION FOR DRAINABILITY

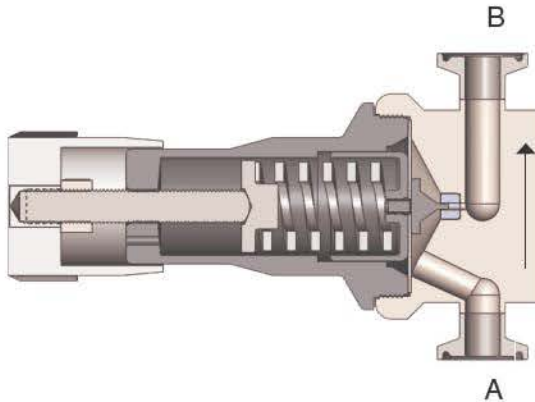

#### Vertical Up Installation

No holdup and drainable with flow\* when spring force is removed.

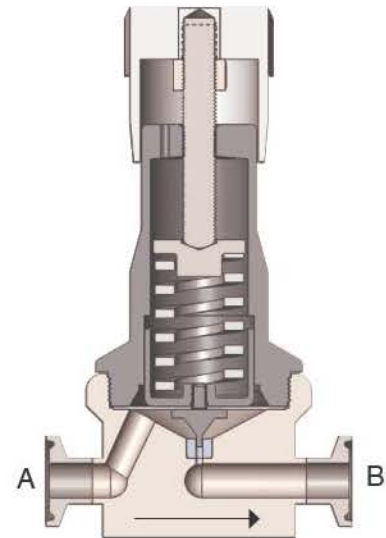

#### Horizontal Installation

No holdup and drainable out port A, and port B with flow\* when spring force is removed.

#### \*Notes

1. For sanitization routines, all spring force should be removed.
2. CIP, Rinse liquids, Clean Steam and drying air must flow from A to B in order to open the valve. With spring force removed, very little pressure is needed to move the diaphragm and plug upward, allowing full velocity flow.

### FLOW CONFIGURATIONS

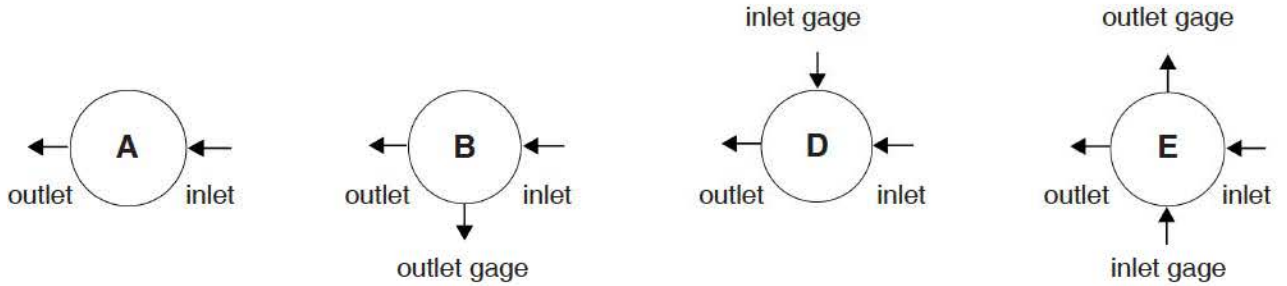

\* Gage ports are 1/4" FNPT (consult factory for required alternative)

### DIMENSIONS, IN. (MM)

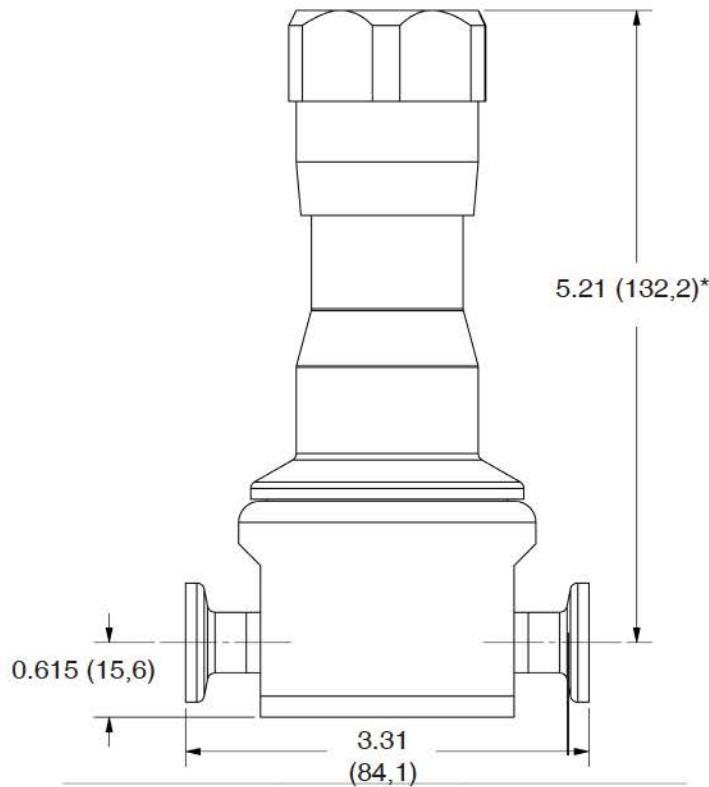

\* Add 0.75" (19,1) for easy removal

### SAMPLE SPECIFICATIONS

Stainless Steel low flow back pressure regulator shall be made from ASTM A479 barstock material, which includes body and all wetted metal parts, and shall have SF5, 20 Ra  $\mu\text{in}$  (0,5 Ra  $\mu\text{m}$ ) electropolish finish as standard on wetted components. Regulator shall be fully drainable out the inlet and outlet when installed with spring housing 90° to ground. Regulator shall be activated by an FDA approved, USP Class VI certified Jorlon diaphragm, stem shall be completely guided above the wet so as not to generate metal particulate. Regulator shall be free of exposed threads and any cracks or crevices within wetted process area. Regulator shall have trim that can be replaced inline by simply unthreading the bonnet and replacing the one piece, diaphragm and trim set. Trim set must be either be TFM, or PEEK, both FDA and USP Class VI approved.

## JSBLF SERIES: COMPACT, HIGH PURITY BIO-PHARMA BACK PRESSURE REGULATING VALVE

## ORDERING SCHEMATIC

Model	Size	Material	1 & 2	3 & 4	5 & 6	7 & 8	9 & 10	11 & 12	13	14	15
JSBLF											

Model	
JSBLF	Compact, High Purity Back Pressure Reducing

Size	
038	3/8" (DN10)
050	1/2" (DN15)
075	3/4" (DN20)

Material / End	
6C	316L Tri-Clamp
6P	316L FNPT
6T	316L ASME BPE BWE
6D	316L DIN
6S	316L ISO

Soft Seat	
T	TFM
P	PEEK

1 & 2	Body Feature	
	End Connection	Port Configuration
1	0.05 Cv	A Port "A"
2	0.15 Cv	B Port "B"
3	0.25 Cv	D Port "D"
4	0.35 Cv	E Port "E"
ZZ	Non-Standard	

3 & 4	Trim
1S	All Cv's
ZZ	Non-Standard

5 & 6	Range Spring / Outlet Pressure
E1	5-50
E2	25-100
E3	50-150
E4	75-250
E5	100-450
E6	200-450
ZZ	Non-Standard

7 & 8	Diaphragm Material
JL	Jorlon
ZZ	Non-Standard

9 & 10	Actuator
SK	Standard Actuator
PM	Panel Mount
CV	Captured Vent
TP	Tamper Proof
ZZ	Non-Standard

11 & 12	Inlet Gauge
ØB	0 - 30 PSIG/Bar (Dual)
ØC	0 - 60 PSIG/Bar (Dual)
ØD	0 - 100 PSIG/Bar (Dual)
ØE	0 - 160 PSIG/Bar (Dual)
ØF	0 - 200 PSIG/Bar (Dual)
ØN	None
ZZ	Non-Standard

13	Outlet Gauge
B	0 - 30 PSIG/Bar (Dual)
C	0 - 60 PSIG/Bar (Dual)
D	0 - 100 PSIG/Bar (Dual)
E	0-160 PSIG/Bar (Dual)
N	None
ZZ	Non-Standard

14	SEP Compliance
0	None Required
G	SEP Compliant
Z	Non-Standard

15	Accessories
0	None Required
S	Clean For Oil Free
X	Clean for Oxygen
Z	Non-Standard



Steriflow, a division of Jordan Valve  
 3170 Wasson Road • Cincinnati, OH 45209  
 513.533.5600 • 800.543.7311 • 513.871.0105 (f)  
 steriflow@richardsind.com • www.steriflowvalve.com

Steriflow Valve reserves the right to make revisions to its product, specifications, literature and related information without notice. Please visit our website at [www.steriflowvalve.com](http://www.steriflowvalve.com) for the latest information on our products.